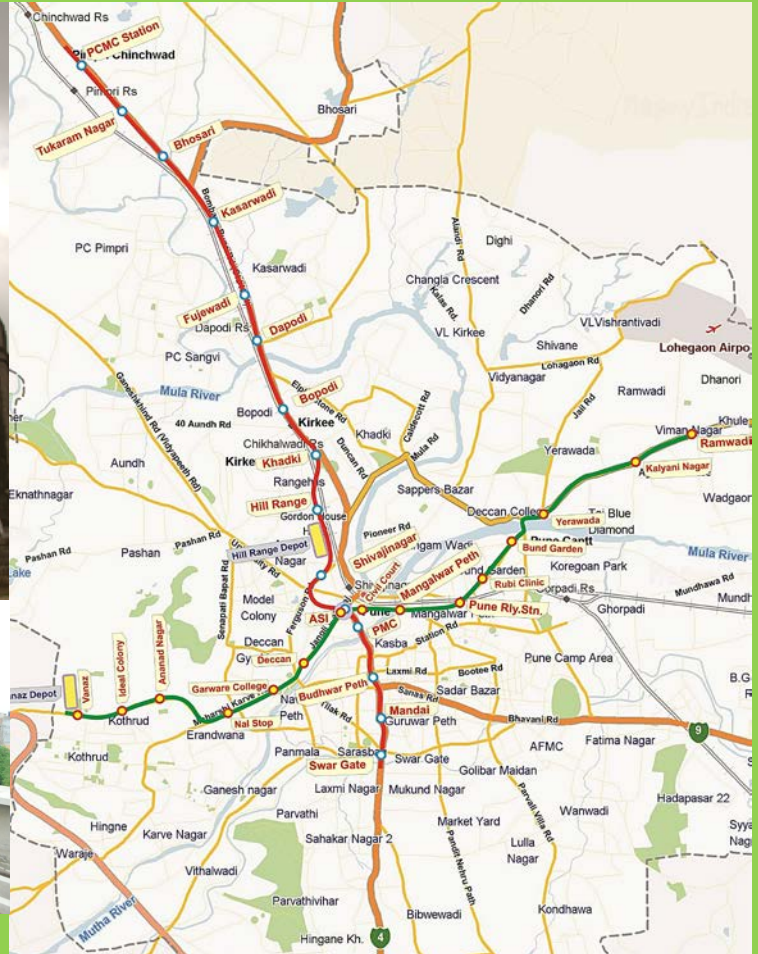


FINAL DETAILED PROJECT REPORT FOR PUNE METRO RAIL PROJECT

Client: PUNE MUNICIPAL CORPORATION



Prepared By:



दिल्ली मेट्रो रेल कॉरपोरेशन लिमिटेड
DELHI METRO RAIL CORPORATION LTD.

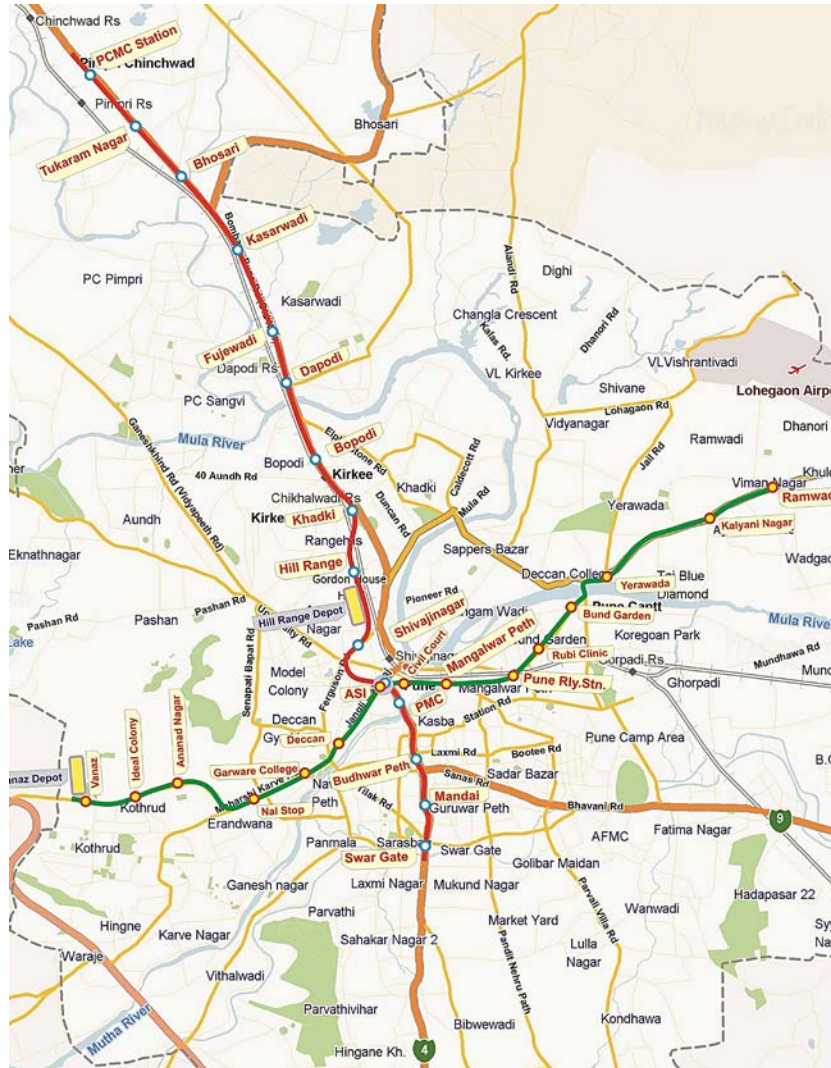
Updated (Nov 2015)

FINAL DETAILED PROJECT REPORT

FOR

PUNE METRO RAIL PROJECT

Client: **PUNE MUNICIPAL CORPORATION**




Prepared By:



दिल्ली मेट्रो रेल कॉर्पोरेशन लिमिटेड
DELHI METRO RAIL CORPORATION LTD.

Aug 2014 Updated For Nov 2015 Prices

Contents

		
	Salient Features	i-iv
	Executive Summary	1-35
Chapter 1	Introduction	36-39
Chapter 2	Traffic Demand Analysis	40-93
Chapter 3	Need for Metro System	94-96
Chapter 4	System Selection	97-133
Chapter 5	Civil Engineering	134-221
Chapter 6	Train Operation Plan	222-246
Chapter 7	Power Supply Arrangement	247-265
Chapter 8	Ventilation and Air-conditioning System	266-278
Chapter 9	Maintenance Depot	279-302
Chapter 10	Environmental Impact Assessment & Management	303-324
Chapter 11	Cost Estimate	324-346
Chapter 12	Financing Options, Fair Structure & Financial Viability	347-371B
Chapter 13	Economic Appraisal	372-380
Chapter 14	Implementation Plan	381-392
Chapter 15	Disaster Management Measures	393-398
Chapter 16	Disabled Friendly Features	399-421
Chapter 17	Security Measures For A Metro System	422-425
Chapter 18	Multi Modal Traffic Integration At Metro Stations And Land Use	426-444
Chapter 19	Conclusions And Recommendations	445-447

FOREWORD





FOREWORD

DMRC is a joint venture of Government of India and Government of Delhi (the Government of the National Capital Territory of Delhi) and has already completed and commissioned phase-I of Delhi Metro (65 kms). DMRC is now implementing phase-II of Delhi Metro covering over 124 kms including a High Speed Rail link from New Delhi Railway Station/Shivaji Stadium (20kms) to the IGI Airport with City check-in facilities. The Detailed Project Report (DPR) for Metro system for number of Indian cities have already been prepared and submitted to respective States for further implementation.

The Delhi Metro Rail Corporation Ltd. (DMRC) was commissioned by Pune (PMC) and Pune Chinchwad (PCMC) Municipal Corporations for preparation of Detailed Project Report (DPR) for about 30 Kms. of Metro network in the Pune Metropolitan area. Accordingly, DMRC undertook necessary studies and investigations and has prepared this DPR.

DMRC carried out the studies and investigations with the assistance of the following organizations:

- | | | |
|-----------------------|---|--|
| Topographical Survey | - | M/s Suncon Engineers, Pune |
| Traffic Survey | - | M/s IIT Mumbai with the assistance of M/s Snehal Engineering Mumbai. |
| Geo-technical studies | - | M/s Oriental Consulting Engineers Pvt. Ltd. Navi Mumbai. |
| Environmental studies | - | M/s Envirotech East Pvt. Ltd., Kolkata |

During the preparation of the Detailed Project Report, there was constant interaction with PMC and PCMC and other Civic agencies. We wish to place on record the assistance rendered by them.

Sd/-

(E. Sreedharan)

Managing Director

Delhi Metro Rail Corporation

New Delhi

12.03.09

Salient Features



- 1.0 Gauge
- 2.0 Route Length Stations
- 3.0 Number of Stations
- 4.0 Traffic Forecast
- 5.0 Train Operation System Design
- 6.0 Speed
- 7.0 Traction Power Supply
- 8.0 Rolling Stock
- 9.0 Maintenance Facilities
- 10.0 Signalling, Telecommunication & Train Control
- 11.0 Fare Collection
- 12.0 Construction Methodology
- 13.0 Estimated Cost
- 14.0 Total Estimated Completion Cost
- 15.0 Funding Pattern Under DMRC Model
- 16.0 Financial Indices



SALIENT FEATURES

1. GAUGE (STANDARD) ... 1435 mm

2. ROUTE LENGTH (BETWEEN DEAD ENDS)

Description	Underground (km)	Elevated (km)	Total (km)
Corridor-1: PCMC - SWARGATE	5.019	11.570	16.589
Corridor-2 : VANAZ - RAMVADI	NIL	14.665	14.665
		Total	31.254

3. NUMBER OF STATIONS

Description	Underground	Elevated	Total
Corridor-1: PCMC - SWARGATE	6	9	15
Corridor-2: VANAZ - RAMVADI	NIL	16	16
		Total	31

4. TRAFFIC FORECAST (IN LAKHS)

Year	Corridor-1	Average Lead(in km)	Corridor-2	Average Lead(in km)
2018	382577	9	189307	5
2021	397229	8	212019	5
2031	443849	7	290515	5

5. TRAIN OPERATION

Corridor	Year	Headway (minutes)	No. of Rakes	Train Composition	Coaches required
Corridor-1 PCMC - SWARGATE	2018	4	19	4 car	76
	2021	3.5	22	4 car	88
	2031	3.5	22	4 car	88
Corridor-2 VANAZ - RAMVADI	2018	12	7	4 car	28
	2021	8	10	4 car	40
	2031	6.5	12	4 car	48

6. SPEED

Designed Speed	...	80 kmph
Scheduled speed	...	33 kmph for Corridor -1
	...	31 kmph for Corridor -2

7. TRACTION POWER SUPPLY

a) Voltage	...	25 KV ac
b) Current Collection	...	Overhead Current collection
c) Power Demand (MVA)		

<u>Year</u>	<u>2018</u>	<u>2021</u>	<u>2031</u>
Corridor I	25.7	27.6	34.2
Corridor II	8.0	10.9	15.9

d) Grid Sub Stations

Corridor I	(i) Chinchwad GSS (220/132 kV), (ii) Ganesh Khind GSS (220/132kV),
------------	---

Corridor II	(i) By LILO from 132 kV transmission line at Kothrud (ii) Khardi GSS (220/132kV)
-------------	---

e) No. of traction substations

Corridor-1	2 Nos
Corridor-2	2 Nos

f) SCADA system Provided

8. ROLLING STOCK

2.90 m wide modern rolling stock with stainless steel body:

a. Axle load	-	16 T
b. Seating arrangement	-	Longitudinal
c. Capacity of 4 coach unit	-	1034 Passengers
d. Class of accommodation	-	One

9. MAINTENANCE FACILITIES

- Maintenance Depot for Corridor-1 - Depot near Hill Range Station
Maintenance Depot for Corridor-2 - Kothrud Depot near Vanaz Station

10. SIGNALLING, TELECOMMUNICATION & TRAIN CONTROL

- a) Type of Signalling - Cab signaling and continuous automatic train control with Automatic Train Protection (ATP)
- b) Telecommunication - i) Integrated System with Fiber Optic cable, SCADA, Train Radio, PA system etc.
- ii) Train information system, Control telephones and Centralized Clock System.

11. FARE COLLECTION

Automatic Fare collection system with POM and Smart card etc.

12. CONSTRUCTION METHODOLOGY

Elevated viaduct consisting prestressed concrete “Box” shaped Girders on Single pier with pile / Open foundations, and underground section with Tunnel Boring and station in underground station cut and cover.

13. TOTAL ESTIMATED COST (AT November 2015 PRICES) WITHOUT TAXES

Corridor I	-	Rs.5333 Crore
Corridor II	-	Rs.2794 Crore
Total	-	Rs.8127 Crore

14. TOTAL ESTIMATED COMPLETION COST (with central taxes):

Corridor I	-	Rs.7,071 Crore (Commissioning in 2021)
Corridor II	-	Rs.3,629 Crore (Commissioning in 2020)
Total	-	Rs.10,700 Crore

15. FUNDING PATTERN UNDER SPV MODEL (WITH TAXES & DUTIES)

Particulars	With Taxes & Duties	
	Amount (Rs/Crore)	% Of contribution
Equity By GOI	1310.00	13.41%
Equity By GOM	1310.00	13.41%
SD for CT by GOM (50%)	644.00	6.59%
SD for CT by GOI (50%)	644.00	6.59%
Grant by Local Bodies	28.50	0.30%
PTA against WORLD BANK AND AIIB Loan @ 0.30% PA	5831.50	59.70%
Total	9768.00	100.00%
SD by GOM for Land including R&R cost and State taxes	302.20	
Subordinate Debts for Land including R&R cost and State Taxes From ULB	1210.80	
Total	11281.00	
Additional PTA for Interest during Construction (IDC)	139.00	WORLD BANK AND AIIB Loan @ 1.40%
Grand Total	11420.00	

16. FINANCIAL INDICES
FIRR

The FIRR for the Subject Metro under various scenarios with Central Taxes and cost of land is tabulated below

Sr. No.	Description	FIRR	Table No.	Remarks
1	FIRR	6.87%	12.9.1(a)	
2	FIRR with additional revenue from increase in Development Charges by 100% and 1% surcharge on stamp duty & registration fees on sale of Property	13.60 %	12.9.1(b)	Considering escalation rate 5%.

a) EIRR

The Economic Internal Rate of Return - EIRR (with central taxes) in economic terms work out to be 16.32 % for the project.

Executive Summary



- 0.1 Introduction
- 0.2 Traffic Demand Forecast
- 0.3 Need For Metro
- 0.4 System Selection
- 0.5 Civil Engineering
- 0.6 Train Operation Plan
- 0.7 Power Requirements
- 0.8 Ventilation & Air-Conditioning System
- 0.9 Maintenance Depot
- 0.10 Environmental Impact Assessment & Management
- 0.11 Cost Estimates
- 0.12 Financial Viability, Fare Structure And Financing Options
- 0.13 Economic Analysis
- 0.14 Implementation Plan
- 0.15 Disaster Management Measure
- 0.16 Disabled Friendly Features
- 0.17 Security Measures For Metro System
- 0.18 Multimodal Traffic Integration And Land Use
- 0.19 Conclusions And Recommendations



EXECUTIVE SUMMARY

0.1 INTRODUCTION

Pune is well known as the 'Queen of Deccan' due to its scenic beauty and rich natural resources. Besides, it is famous for its religious and historical places. Pune city is known in the world map because of its educational, research and development institutions. The district also has an importance as an important military base. Pune is the most industrialized district in western Maharashtra and a famous IT hub in the country. Pune exemplifies an indigenous Marathi culture and ethos, in which education, arts & crafts and theaters are given due prominence. Pune is the cultural capital of Maharashtra. It is the birth place of the poet-saint Tukaram. It is the home of great freedom fighters like Bal Gangadhar Tilak, Agarkar and Gopal Krishna Gokhale. Jayant Narlikar, the famous contemporary scientist is from Pune.

Location

Pune district is located between 17° 54' and 10° 24' North Latitude and 73° 19' and 75° 10' East Longitude. The district is bound by Ahmadnagar district on the north-east, Solapur district on the south-east, Satara district on south, Raigad district on the west and Thane district on the north-west. Pune district forms a part of the tropical monsoon land and therefore shows a significant seasonal variation in temperature as well as rainfall conditions. Climate of the western region of Pune is cool whereas the eastern part is hot and dry.

Road Network

Pune district is well connected with the state capital and surrounding headquarters through road and rail linkages. The road network consists of Express Highways, National Highways, State Highways and Major District Roads. The district has total length of 13,642 km of roads. Following National Highways pass through the district :

1. National Highway No. 4 (Mumbai-Bangalore)
2. National Highway No. 9 (Pune-Solapur-Hyderabad)
3. National Highway No. 50 (Pune-Nashik).

Rail Network

The district has a total rail network of 311 km. Pune and Daund are the two major junction stations. Following are the three main railway routes pass through the district:

1. Mumbai-Pune-Solapur
2. Pune-Miraj
3. Daund-Baramti.

Air Route

Pune is well connected through domestic airlines with the entire country. The airport located at Lohgaon has recently acquired status of an international airport. Also it is proposed to develop an international air-cargo hub near Khed Tahsil of the district.

Study Area

The study area has been taken as the area comprising the present Pune Corporation (PMC), Pimpri Chinchwad Municipal Corporation (PCMC) and both the cantonment areas namely Pune and Khadki. The zoning system of the study area comprise of 53 zones in the PMC area and 38 zones in PCMC area. Pune and Khadki cantonments have been considered as two zones. In addition to 91 internal zones, 13 external zones are considered.

Demographic Profile

The total population of the study area in 2001 was 35.6 lakhs. The decadal growth in PCMC area is almost 100% in the past 3 decades. PMC area has registered an average decadal growth of around 35% and a decline in population is observed in both the cantonments. The population figures of study area for the base year 2011 and estimated population for the horizon years are as under:

Table 0.1 - Estimated Population in Different Areas of Study Area

Region	2011	2021	2031
PMC	3115431	4807868	5443642
PCMC	1729320	1915320	2106123
Pune Cantonment	67861	88603	93134
Khadki Cantonment	77417	85600	89977
Total	4992040	6899412	7734907

0.2 TRAFFIC DEMAND FORECAST

Based on the experience of Delhi Metro the optimistic projections are normally not achieved and it is felt that initially the most likely rider ship may only materialize. Hence, the all further planning for the Metro infrastructure is done for catering the most likely projections.

0.2.1 Daily Ridership, Passenger km and Average Lead

Table 0.2 - Pimpri Chinchwad (PCMC) – Swargate Section

Year	2018	2021	2031
Daily Ridership	382577	397229	443849
Passenger km	3443190	3177832	3106943
Average Lead	9	8	7

Table 0.3 - Vanaz – Ramvadi Section

Year	2018	2021	2031
Daily Ridership	189306	212019	290515
Passenger km	946532	1060095	1452575
Average Lead	5	5	5

0.3 NEED FOR METRO

Public Transport System is an efficient user of space and with reduced level of air and noise pollution. As the population of a city grows, share of public transport, whether road or rail-based, should increase. Experience has shown that, in cities like Pune where roads do not have adequate width and which cater to mixed traffic conditions comprising slow and fast moving vehicles, road transport can optimally carry 8,000 persons per hour per direction (phpdt). When traffic density increases beyond this level, average speed of vehicles comes down, journey time increases, air pollution goes up and commuters are put to increased level, of inconvenience. Thus when on a corridor, traffic density during peak hours crosses this figure, provision of rail-based mass transport, i.e. Metro system should be considered.

- **Advantages Of Metro System**

- Requires 1/5th energy per passenger km compared to road-based system.
- Causes no air pollution in the city.
- Causes lesser noise level
- Occupies no road space, if underground and only about 2 metres width of the road, if elevated.

- Carries same amount of traffic as 5 lanes of bus traffic or 12 lanes of private motor cars (either way), if it is a light capacity system.
- Is more reliable, comfortable and safer than road based system
- Reduces journey time by anything between 50% and 75% depending on road conditions.

0.4 SYSTEM SELECTION

A. Permanent Way

- **Choice Of Gauge**

Standard Gauge (1435mm) is invariably used for metro railways world over due to its inherent advantages. During the last decade, 20 new metros have been constructed in various cities of the world. All these metros have gone in for Standard Gauge even though the national gauge for mainline railways in some of these countries was different from Standard Gauge. In India the national gauge is Broad Gauge (1676mm). Reasons for selection of Standard gauge are described in the Report.

- **Track Structure**

Track on Metro Systems is subjected to intensive usage with very little time for day-to-day maintenance. Thus it is imperative that the track structure selected for Metro Systems should be long lasting and should require minimum or no maintenance and at the same time, ensure highest level of safety, reliability and comfort, with minimum noise and vibrations. Ballastless track with continuous welded head-hardened rails has been proposed as mainline track in elevated and underground stretches. However for at-grade section and at depot the track structure shall be ballasted.

B. Traction System

Keeping in view the ultimate traffic requirements, standardization, and other techno-economic considerations, 25 kV ac Over Head Electrification (OHE) traction system is proposed for adoption on Pune Metro System.

C. Signaling And Train Control

Metro carries large number of passengers at a very close headway requiring a very high level of safety enforcement and reliability. At the same time heavy investment in infrastructure and rolling stock necessitates optimization of its capacity to provide the best services to the public. These requirements of the metro are planned to be achieved by adopting ATP (Automatic Train Protection) and ATS (Automatic Train Supervision) signaling systems. Automatic Train Operation (ATO) will be added in future.

D. Telecommunication

The telecommunication system acts as the communication backbone for Signaling systems and other systems such as SCADA, AFC, etc and provides telecommunication services to meet operational and administrative requirements of metro network.

The telecommunication facilities proposed are helpful in meeting the requirements for

1. Supplementing the Signaling system for efficient train operation.
2. Exchange of managerial information
3. Crisis management during emergencies
4. Passenger information system

The proposed telecom system will cater to the following requirements:

- Train Traffic Control
- Assistance to Train Traffic Control
- Maintenance Control
- Emergency Control
- Station to station dedicated communication
- Telephone Exchange
- Passenger Announcement System and Passenger Information and Display System within the station and from Central Control to each station.
- Centralized Clock System
- Train Destination Indicator
- Instant on line Radio Communication between Central Control and Moving trains and maintenance personnel.
- Data Channels for Signaling, SCADA, Automatic Fare Collection, etc.

E. Automatic Fare Collection

Mass Rapid Transit Systems handle large number of passengers. Ticket issue and fare collection play a vital role in the efficient and proper operation of the system. To achieve this objective, ticketing system shall be simple, easy to use/operate and maintain, easy on accounting facilities, capable of issuing single/multiple journey tickets, amenable for quick fare changes and require overall lesser manpower. In view of above, computer based automatic fare collection system is proposed.

AFC system proves to be cheaper than semi-automatic (manual system) in long run due to reduced manpower cost for ticketing staff, reduced maintenance in comparison to paper ticket machines, overall less cost of recyclable tickets (Smart Card/Token) in comparison to paper tickets and prevention of leakage of revenue.

F. Rolling Stock

Rolling stock for Pune Metro has been selected based on the following criteria:

- Proven equipment with high reliability
- Passenger safety feature
- Energy efficiency
- Light weight equipment and coach body
- Optimized scheduled speed
- Aesthetically pleasing Interior and Exterior
- Low Life cycle cost
- Flexibility to meet increase in traffic demand
- Anti-telescopic.

The controlling criteria are reliability, low energy consumption, lightweight and high efficiency leading to lower annualized cost of service. The coach should have high rate of acceleration and deceleration.

The following optimum size of the coach has been chosen for this corridor as mentioned below:-

Description	Length	Width	Height
Driver Motor Car	21.64 m	2.9 m	3.9 m
Motor/Trailer car	21.34 m	2.9 m	3.9 m
Maximum length of coach over coupler/buffer is 22.6 m			

0.5 CIVIL ENGINEERING

Geometric Design Norms

The design parameters related to the Metro system described herewith have been worked out based on a detailed evaluation, experience and internationally accepted practices. Various alternatives were considered for most of these parameters but the best-suited ones have been adopted for the system as a whole.

Horizontal curves are provided with:-

Description	Underground Section	Elevated Section
Desirable Minimum	300 m	200 m
Absolute minimum	200 m	120 m
Minimum curve radius at stations	1000 m	1000 m
Maximum permissible cant (Ca)	125 mm	125 mm
Maximum cant deficiency (Cd)	100 mm	100 mm

Elevated Sections

The viaducts carrying the tracks will have a vertical clearance of minimum 5.5 m above road level. For meeting this requirement with the 'Box' shaped pre-stressed concrete girders, the rail level will be about 9.8 m above the road level. However, at stations which are located above central median, the rail level will be 12.5 m above the road level with concourse at mezzanine. These levels will, however, vary marginally depending upon where the stations are located.

The track center on the elevated section is kept as 4.0 m uniform throughout the corridor to standardize the superstructure, except at few locations as detailed below:

- On curves below 300m Radius
but upto 120m Radius 4.10 m
- At scissors crossings 4.50 m

Underground sections

Rail level at midsection in tunneling portion shall be kept at least 12.0 m below the ground level so that a cover of 6m is available over the tunnels. At stations, the desirable depth of rail below ground level is 12.5 m, Track centre in underground section to be constructed by Tunnel Boring Machine (TBM) is 15.05 m to accommodate a 12 m wide island platform. Track centre in underground section to be constructed by cut and cover method is 4.5m.

Gradients

Normally the stations shall be on level stretch. In limiting cases station may be on a grade of 0.1 %. Between stations, generally the grades may not be steeper than 2.0 %. However, where existing road gradients are steeper than 2 %, gradients or for Switch Over Ramps, grade up to 4% (compensated) can be provided in short stretches on the main line.

Design Speed

The maximum sectional speed will be 80 km/h. However, the applied cant, and length of transition will be decided in relation to normal speeds at various locations, as determined by simulation studies of alignment, vertical profile and station locations.

Geometrical design norms are based on international practices adopted for similar metro systems with standard gauge on the assumption that the maximum permissible speed on the section is limited to 80 Kmph. Horizontal alignment and vertical alignment are dictated to a large extent by the geometry of the road followed by the alignment.

Route Alignment

Corridor -1 : Pimpri Chinchwad (PCMC) – Swargate

Alignment from (-) 450 m to 16589 m

From dead end (Ch. – 450 m) of PCMC station to dead end of Swargate station (Ch. 16139m), the length of corridor 1 is 16.589 km, out of which 5. km is underground and remaining 11.570 km is elevated Including length of Switch Over Ramp(SWR). Total 15 numbers of stations have been planned along this corridor out of which 9 are elevated and 6 are underground stations.

Corridor -2 : Vanaz (Kothrud) – Ramvadi

Alignment from (-) 684.8 m to 14665 m

From dead end (Ch – 684.8 m) of Vanaz station to dead end of Ramvadi station (Ch. 13790m), the length of corridor 2 is 14.665 km. Total 16 number of elevated stations have been planned along this corridor.

Viaduct Structure

The proposed viaduct structure for Pune Metro is Pre-cast segmental box girder, carrying two tracks supported on single pier located on the median of the road. Road clearance of 5.5 m is ensured below the viaduct structure. The foundation shall be pile foundation at most of the locations. Open foundations are possible at certain isolated locations. The superstructure shall be pre-cast segmental construction which will cause minimal inconvenience to the road users during the execution stage.

Station Locations & Planning

Stations have been located so as to serve major passenger destinations and to enable convenient integration with other modes of transport. However effort has also been made to propose station locations, such that inter station distances are as uniform and the average spacing of stations is close to one km as possible.

Sequence of Stations

The sequence of stations along with their respective chainages, site and platform characteristics are presented in the Table 0.4:-

Table 0.4 - Station Location Characteristics

S. No.	Name of Station	Chainage (in m)	Distance from previous station (in m)	Rail level (in m)	Ground Level (in m)	Platform type	Alignment
Corridor 1 : Pimpri Chinchwad (PCMC) to Swargate							
	Dead End	(-)450.000	-				
1	PCMC	0.000	-	588.250	575.200	Side	Elevated
2	Tukaram Nagar	1763.264	1763.264	575.800	562.870	Side	Elevated
3	Bhosari (Nashik Phata)	2974.275	1211.011	570.400	557.250	Side	Elevated
4	Kasarwadi	3748.615	774.340	574.200	561.240	Side	Elevated
5	Fugewadi	4923.064	1174.449	564.200	550.500	Side	Elevated
6	Dapodi	6018.188	1095.124	564.200	555.600	Side	Elevated
7	Bopodi	7206.181	1187.993	568.600	555.670	Side	Elevated
8	Khadki	7977.395	771.214	572.700	559.740	Side	Elevated
9	Range Hill	10185.226	2207.831	562.200	552.700	Side	Elevated
10	Shivaji Nagar	11789.640	1604.414	538.500	551.100	Island	Underground
11	A S I	12432.292	642.652	542.500	554.870	Island	Underground
12	P M C	12848.000	415.708	549.000	551.660	Island	Underground
13	Budhwar Peth	13866.261	1018.261	541.500	556.500	Island	Underground
14	Mandai	14742.084	875.823	549.000	562.610	Island	Underground
15	Swargate	15688.959	946.875	563.000	576.200	Island	Underground
	Dead End	16138.959	450.000	563.000	576.630	-	Underground

S. No.	Name of Station	Chainage (in m)	Distance from previous station (in m)	Rail level (in m)	Ground Level (in m)	Platform type	Alignment
Corridor 2- Vanaz (Kothrud Depot) to Ramwadi							
	Dead End	-684.790					
1	Vanaz	0.000	-	596.500	584.278	Side	Elevated
2	Anand Nagar	994.699	994.699	595.000	582.250	Side	Elevated
3	Ideal Colony	1900.000	905.301	586.806	575.222	Side	Elevated
4	Nal Stop	2875.274	975.274	574.700	562.000	Side	Elevated
5	GARVARE COLLEGE	3878.2	1004.283	567.00	553.80	Side	Elevated
6	DECCAN	4629.8	751.53	558.70	544.434	Side	Elevated
7	SAMBHAJI PARK	5222.9	593.15	561.10	547.402		
8	PMC	6053.2	830.31	561.70	548.067	Side	Elevated
9	CIVIL COURT	6568.1	514.91	563.20	549.602	Side	Elevated
10	Mangalwar Peth	7671.332	1056.541	564.500	551.850	Side	Elevated
11	Pune Railway Station	8584.185	376.696	569.500	556.700	Side	Elevated
12	Ruby Clinic	9379.712	795.527	567.500	554.730	Side	Elevated
13	Bund Garden	10430.686	1050.974	561.600	548.670	Side	Elevated
14	Yerawada	11292.383	861.697	560.500	545.173	Side	Elevated
15	Kalyani Nagar	12660.667	1368.284	568.000	555.000	Side	Elevated
16	Ramwadi	13789.667	1129.000	570.300	557.350	Side	Elevated
	Dead End	14239.667	450.000				

Stations have been divided into two distinct areas, namely public and non-public (technical areas). The public area is further sub divided into unpaid and paid area. Provision for escalators are made at all stations in paid area from the beginning itself. Provision in civil structures at stations is being kept for providing lifts for disabled passengers in future.

Integration facilities at Metro stations include approach roads to the stations, circulation facilities, pedestrian ways and circulation areas for various modes likely to come to important stations, including feeder buses. Parking for private vehicles has not been proposed in view of the scarcity of land along the alignment

Geo technical Investigations

A total of 44 bore holes have been drilled along the proposed two corridors..

Geotechnical investigations were carried out along the corridor up to a depth varying up to 30 m. Soil and rock samples were collected and tested in laboratory.

Utilities

The proposed Metro alignment is passing along major arterial roads of the city road network, which are serving institutional, commercial and residential areas. A large number of surface and sub-surface utility services, viz. sewers, water-mains, storm water drains, telephone cables, electric poles, traffic signals, etc. are existing along the proposed alignment. Details of the existing utility services along the proposed alignment have been collected from the concerned authorities.

Land Requirement

Since land is a scarce commodity especially in metropolitan areas, every effort has been made to keep land requirement to the barest minimum and acquisition of private property is minimal. Land is mainly required for Depots and route alignment on sharp bends, station buildings, platforms, entry/exit structures, traffic integration, power sub-stations, ventilation shafts, administrative buildings and temporary construction depots / work sites etc.

Abstract of land requirements for Corridor -1 and Corridor-2 is given in Table 0.5:

Table 0.5 - Summary of Permanent Land Requirement (Ha)

S.No.	Description	Corr I			Corr II		
		Govt.	Pvt.		Govt.	Pvt.	
			Comm.	Res.		Comm.	Res.
1.	Stations	4.2	--	0.80	0.30	0.60	1.53
2.	Running Section	0.50	6.80	0.80	0.55	0.980	1.17
3.	RSS/TSS	1.20	--	--	1.20	--	--
4.	Depots	11.51	--	--	12.11	--	--
	Total	17.41	6.80	1.60	14.16	1.58	2.70

Total Land required for both corridors: 31.57Ha (Govt.) + 12.68Ha (Pvt.) = 44.25 Ha.

0.6 TRAIN OPERATION PLAN

0.6.1 OPERATION PHILOSOPHY

The underlying operation philosophy is to make the MRT System more attractive and economical, the main features being:

- Selecting the most optimum frequency of Train services to meet sectional capacity requirement during peak hours on most of the sections.
- Economical & optimum train service frequency not only during peak period, but also during off-peak period.
- A short train consist of 4 coaches with high frequency service which can be increased to 6 Coaches to meet future requirements.
- Multi-tasking of train operation and maintenance staff.

Salient Features of the proposed trains operation plan are:-

- Running of services for 19 hours of the day (5 AM to Midnight) with a station dwell time of 30 seconds,
- Make up time of 5-10% with 8-12% coasting.
- Scheduled speed for these corridors has been taken as 33 Kmph for Corridor-1 & 31 Kmph for Corridor-2.

Requirements of coaches is calculated based on following assumptions:-

The basic unit of 4-car train comprising of DTC-MC-MC- DTC configuration has been selected for the Pune Metro Corridors for the year 2018, 2021 & 2031.

Composition

DTC : Driving Trailer Car

MC : Motor Car

TC : Trailer Car

4 Car Train Composition DTC + MC + MC+ DTC

6 Car Train Composition DTC + MC + TC + MC + MC + DTC

Capacity

DTC : 247 passenger (Sitting-43, Crush Standing-204)

TC/MC : 270 passenger (Sitting-50, Crush Standing-220)

4 Car Train: 1034 Passengers (Sitting-186, Crush Standing-848)

6 Car Train: 1574 Passengers (Sitting-286, Crush Standing-1288)

Based on Train formation and headway as decided above to meet Peak Hour Peak Direction Traffic Demand, Rake requirement has been calculated and enclosed as **Attachment V** & has been tabulated below:

Table 0.6 – Rake Requirement

Corridor	Year	Headway (min)	No. of Rakes	Rake Consist	No. of Coaches
Pune Metro Corridor-1	2018	4	19	4 car	76
	2021	3.5	22	4 car	88
	2031	3.5	22	4 car	88

Corridor	Year	Headway (min)	No. of Rakes	Rake Consist	No. of Coaches
Pune Metro Corridor-2	2018	12	7	4 car	28
	2021	8	10	4 car	40
	2031	6.5	12	4 car	48

Requirements of coaches is calculated based on following assumptions-

- (i) Train Composition planned as under
 - 4 Car Train Composition : DTC-MC-MC-DTC
 - Train Carrying Capacity of 4 Car Train : 1034 passengers
- (ii) Coach requirement has been calculated based on headway during peak hours.
- (iii) Traffic reserve is taken as one train per section to cater to failure of train on line and to make up for operational time lost.
- (iv) Repair and maintenance reserve has been estimated as 8 % of total requirement (Bare +Traffic Reserve).
- (v) The calculated number of rakes in fraction is rounded off to next higher number.
- (vi) Schedule speed is taken as 33 KMPH & 31 KMPH respectively for Corridor 1 & 2.
- (vii) Total Turn round time is taken as 6 min at terminal stations.

0.7 POWER REQUIREMENTS

Power supply is required for operation of Metro system for running of trains, station services (e.g. lighting, lifts, escalators, tunnel ventilation system, signaling & telecom, fire fighting etc) and workshops, depots & other maintenance infrastructure within premises of

metro system. The major component of power supply is traction requirements for elevated sections and auxiliary requirements for Underground section.

The power requirements of a metro system are determined by peak-hour demands of power for traction and auxiliary applications. Broad estimation of auxiliary and traction power demand is made based on the following assumptions:-

- (i) Specific energy consumption of rolling stock – 70KWh/1000 GTKM
- (ii) Regeneration by rolling stock – 30%.
- (iii) Elevated/at –grade station load – initially 200KW, which will increase to 300 KW inclusive of Property Development loads in the year 2031.
- (iv) Underground Station load – initially 2000 kW, which will increase to 2500 kW in the year 2031.
- (v) Depot auxiliary load – initially 1000KW, which will increase to 2000 KW in the year 2031.

Keeping in view of the train operation plan and demand of auxiliary and traction power, power requirements projected for the year 2018, 2021 and 2031 are summarized in table 0.7 below :-

Table 0.7 - Power Demand Estimation (MVA)

Corridor		Year		
		2018	2021	2031.
Corridor - 1 Pimpri Chinchwad--Shivaji nagar – Swar Gate. [16.59 km & 15 Stns. (6 U/G)].	Traction	6.8	7.6	7.6
	Auxiliary	18.9	20.0	26.6
		25.7	27.6	34.2
Corridor - 2 Kothrud Depot (Vanaz) – Pune railway station – Ram Vadi. [14.93 kms & 16 Stns.].	Traction	2.8	3.6	4.2
	Auxiliary	5.2	7.3	11.7
		8.0	10.9	15.9

Sources of Power Supply

The high voltage power supply network of Pune city has 220kV and 132kV and network to cater to various types of demand in vicinity of the proposed corridor. 220 kV Sub Stations are generally located at outskirts of the city. 220/132 kV sub stations and some 132 KV Transmission lines are located /passing near to the alignment of Corridors. Keeping in view the reliability requirements, two input sources of 132 kV Voltage level are normally

considered for each corridor. Accordingly, two Receiving Sub Stations (132 / 33/25 kV) are proposed to be set up for Corridor I & Corridor –II each. Based on the discussions with Pune power supply authorities, it is proposed to avail power supply for traction as well as auxiliary services from the following grid sub-stations at 132 kV voltage through double cable feeders. The input sources for these four grid sub stations are different therefore the reliability enhances further: Sources of Power Supply is given in Table 0.8.

Table 0.8 - Sources of Power Supply

Corridor	Grid sub-station (with Input voltage)	Location of RSS of Metro Authority
Corridor - I PCMC –Swargate.	Chinchwad GSS (220 / 132kV)	Near PCMC (132 / 33/25 kV).
	Ganesh Khind GSS (220 / 132 kV).	RSS near Agriculture College (132 / 33/25 kV)
Corridor - II Kothrud Depot (Vanaz) - Ram Vadi.	By LILO From 132 KV transmission line at Kothrud	Near Kachara Depot (132 / 33/25 kV)
	Khardi Grid Sub Station (220 / 132 kV).	Near RamVadi (132 / 33/25 kV)

Summary of expected power demand at various sources is given in Table – 0.9.

Table 0.9 - Power Demand Projection for various sources

Corridor	Input Source	Demand – Normal (MVA)		Demand – Emergency (MVA)	
		2018	2031	2018	2031
Corridor - I Pimpri Chinchwad – Shivaji nagar – Swargate	RSS Near PCMC office				
	Traction	3.8	4.3	6.8	7.6
	Auxiliary	2.2	5.6	18.9	26.6
	Sub – Total (A)	6.0	9.9	25.7	34.2
	RSS near Agriculture College				
	Traction	3.0	3.3	6.8	7.6
	Auxiliary	16.7	21.0	18.9	26.6
Sub – Total (B)	19.7	24.3	25.7	34.2	
	TOTAL (A + B)	25.7	34.2		
Corridor - II Kothrud Depot (Vanaz)–Pune railway station-	RSS near Kachara Depot				
	Traction	2.0	2.7	2.8	4.2
	Auxiliary	3.2	6.8	5.2	11.7
	Total	5.2	9.5	8.0	15.9

Corridor	Input Source	Demand - Normal (MVA)		Demand - Emergency (MVA)	
		2018	2031	2018	2031
RamVadi.	RSS Near Ramvadi				
	Traction	0.8	1.5	2.8	4.2
	Auxiliary	2.0	4.9	5.2	11.7
	Total	2.8	6.4	8.0	15.9
	TOTAL (A + B)	8.0	15.9		

Auxiliary Supply Arrangements for Stations & Depot

Auxiliary sub-stations (ASS) are envisaged to be provided at each station (3 ASS's for Underground stations and 1 ASS for elevated station) for stepping down 33 kV supply to 415 V for auxiliary applications. A separate ASS is required at depot. The ASS will be located at mezzanine or platform level inside a room. The auxiliary load requirements have been assessed at 200kW for elevated / at-grade stations which is likely to increase up to 500 KW in the year 2031 and 2000 kW for Underground Station which is likely to increase up to 2500 KW in the year 2031. In order to meet the requirement of auxiliary power two dry type cast resin transformers (33/0.415kV) of 500kVA capacity are proposed to be installed at the elevated stations (one transformer as standby) and one transformer of 1.6 MVA at each underground ASS. For Property Development within the footprints of the station, a provision to add third transformer at a later date may be kept at elevated station.

Standby Diesel Generator (DG) Sets

In the unlikely event of simultaneous tripping of all the input power sources or grid failure, the power supply to stations as well as to trains will be interrupted. It is, therefore, proposed to provide a standby DG set of 200 KVA capacities at the elevated stations and 2 X 1000/750 KVA at Under Ground Stations to cater to the following essential services:

- (i) Essential lighting
- (ii) Signaling & telecommunications
- (iii) Fire fighting system
- (iv) Lift operation
- (v) Fare collection system

Silent type DG sets with low noise levels are proposed, which do not require a separate room for installation.

Supervisory Control and Data Acquisition (SCADA) System

The entire system of power supply (receiving, traction & auxiliary supply) shall be monitored and controlled from a centralized Operation Control Centre (OCC) through SCADA system. Modern SCADA system with intelligent remote terminal units (RTUs) shall be provided. Optical fibre provided for telecommunications will be used as communication carrier for SCADA system.

Digital Protection Control System (DPCS) is proposed for providing data acquisition, data processing, overall protection control, interlocking, inter-tripping and monitoring of the entire power supply system consisting of 132/33kV ac switchgear, transformers, 25 KV ac switchgear and associated electrical equipment. DPCS will utilize microprocessor-based fast-acting numerical relays & Programmable Logic Controllers (PLCs) with suitable interface with SCADA system.

Energy Saving Measures

Energy charges of any metro system constitute a substantial portion of its operation & maintenance (O & M) costs. Therefore, it is imperative to incorporate energy saving measures in the system design itself. The auxiliary power consumption of metros is generally more than the traction energy consumed by train movement during initial years of operation. Subsequently, traction power consumption increases with increase in train frequency/composition in order to cater more traffic. The proposed system of Pune Metro includes the following energy saving features:

- (i) Modern rolling stock with 3-phase VVVF drive and lightweight stainless steel coaches has been proposed, which has the benefits of low specific energy consumption and almost unity power factor.
- (ii) Rolling stock has regeneration features and it is expected that 30% of total traction energy will be regenerated and fed back to 25 KV ac OHE to be consumed by nearby trains.
- (iii) Effective utilization of natural light is proposed. In addition, the lighting system of the stations will be provided with different circuits (33%, 66% & 100%) and the relevant circuits can be switched on based on the requirements (day or night, operation or maintenance hours etc).
- (iv) Machine-room less type lifts with gearless drive have been proposed with 3-phase VVVF drive. These lifts are highly energy efficient.
- (v) The proposed heavy-duty public services escalators will be provided with 3-phase VVVF drive, which is energy efficient & improves the power factor.

Further, the escalators will be provided with infrared sensors to automatically reduce the speed (to idling speed) when not being used by passengers.

- (vi) The latest state of art and energy efficient electrical equipment (e.g. transformers, motors, light fittings etc) have been incorporated in the system design.
- (vii) Efficient energy management is possible with proposed modern SCADA system by way of maximum demand (MD) and power factor control.

8.0 VENTILATION AND AIR-CONDITIONING SYSTEM

The underground stations of the Metro Corridor are built in a confined space. A large number of passengers occupy concourse halls and the platforms, especially at the peak hours. The platform and concourse areas have a limited access from outside and do not have natural ventilation. It is therefore, essential to provide forced ventilation in the stations and inside the tunnel for the purpose of:-

- Supplying fresh air for the physiological needs of passengers and the authority's staff;
- Removing body heat, obnoxious odors and harmful gases like carbon dioxide exhaled during breathing;
- Preventing concentration of moisture generated by body sweat and seepage of water in the sub-way;
- Removing large quantity of heat dissipated by the train equipment like traction motors, braking units, compressors mounted below the under-frame, lights and fans inside the coaches, A/c units etc.;
- Removing vapour and fumes from the battery and heat emitted by light fittings, water coolers, Escalators, Fare Gates etc. working in the stations;
- Removing heat from air conditioning plant and sub-station and other equipment, if provided inside the underground station.

This large quantity of heat generated in M.R.T. underground stations cannot be extracted by simple ventilation, especially when the outdoor air temperature and humidity is high. It is, therefore, essential to provide mechanical cooling in order to remove the heat to the maximum possible extent. As the passengers stay in the stations only for short periods, a fair degree of comfort conditions are considered appropriate. In winter months it may not be necessary to cool the ventilating air as the heat generated within the station premises would be sufficient to maintain the comfort requirement.

The train heat generated inside the tunnel sections would be removed by the train piston action. It is envisaged that for the design outside conditions, it may not be necessary to provide forced ventilation using Tunnel Ventilations Fans for normal operating conditions. The two tunnel ventilation shafts would be required at the end of the stations. As the maximum inter station distance in under ground stations is 1057.7m therefore considering the ultimate train headway the mid tunnel ventilation shaft would not be required. These end-shafts at the stations also serve as Blast Relief Shafts i.e. the piston pressure is relieved to the atmosphere before the air-blast reaches the station.

Tunnel Ventilation Systems (TVS)

The TVS is provided in a Subway system essentially to carry out the following functions:

- (a) Train Pressure relief during normal operation
- (b) Ventilation during maintenance periods, if required
- (c) Removal of smoke during emergency conditions
- (d) Maintenance of smoke free evacuation route and provision of adequate fresh air during fire related emergencies.

Ventilation and Air Conditioning of Ancillary Spaces

Ancillary spaces such as staff room, equipment plant room, will be mechanically ventilated or air conditioned in accordance with the desired air change rates and temperatures/humidity.

Station Air Conditioning

The platform and concourse areas will be air-conditioned using supply 'air handling units' located in Environmental Control plant rooms throughout the station. Each platform will be served by at least two separate air handling units (AHU's) with the distribution systems combined along each platform to ensure coverage of all areas in the event of single equipment failure. Based on the initial estimation about 6 units (2 for the concourse each with 18 cum/s and 4 for the platform each having 24 cum/s air-flow) would be needed for the full system capacity.

Tunnel Ventilation System

As described earlier tunnel ventilation fans will be installed in each of the fan rooms near vent shafts. There shall be two fans in a fan room at each end of the station. The fan capacity depends on the inter-station distances and may vary from 60 m³/s to 100 m³/s. The exact capacity will be obtained through the simulation during detailed stage. If necessary, nozzle

type structures made up of concrete or steel may also be constructed to achieve desired airflow and air velocity in the tunnel sections. Alternatively booster fans (jet fans) may be installed to direct the flow in the desired direction. These fans may also be used for emergency ventilation at crossover locations.

Space Requirement for VAC System

The station air conditioning and tunnel ventilation equipment plant room are normally located at each end of the concourse for the two level stations. The approximate area for air handling equipment room would be 400 sq. m and for tunnel ventilation fan room would be 600 sq. m. respectively at each end of the station. The tunnel vent shafts of approximately 20 sq. m. area will be constructed at each end of the stations. There shall be supply shaft and exhaust shafts at the stations of similar dimensions. For the underground stations with large inter station distances there may be necessity of constructing mid tunnel shaft. Considering the ultimate headway of 3-minute and the inter-station distances in Pune metro corridor the mid tunnel ventilation shafts are not required.

However, the adjacent station's end shafts will have fans with higher pressure since thrust required will be more. We can reduce the pressure (and also fan power requirement) if booster fans are used but this is preferred if cut-cover tunnel sections is there. Computer simulation during design stage would tell about the need of mid tunnel cooling dumping. Although increase in in-bound dumping can eliminate this need. Train AC condensers should work at full load till 50 °C.

Control and monitoring Facilities

For the underground stations the control and monitoring of station services and systems such as station air-conditioning, ventilation to plant rooms, lighting, pumping systems, lifts & Escalators, etc shall be performed at Station Control Room (SCR). However, the operation and control of Tunnel Ventilation as well as Smoke Management system will normally be done through OCC. All these systems shall be equipped with automatic, manual, local and remote operation modes. The alarms and signals from the equipment at stations shall be transmitted to the OCC via communication network (such as FOTS).

0.9 MAINTENANCE DEPOTS

Two Depot-cum-Workshops are proposed, one near Hill Range station for Corridor 1 and the other at Kothrud near Vanaz station for Corridor 2. These depots will be used for stabling of trains, cleaning, schedule inspections, wheel-re-profiling, minor & major repairs as well as Overhauls. Trains operational on the two corridors shall have stabling facilities at terminal station also.

It is proposed that Depot cum Workshop near Hill Range station may be used for stabling, washing, scheduled inspection, wheel re-profiling and overhaul for Corridor 1 while the depot at Kothrud (smaller in size) may be used for stabling, washing & scheduled inspections for corridor 2. Since the platforms on both the corridors have been planned for the length of 6-car train formations, the inspection sheds and workshops sheds are also proposed to be dimensionally in accordance with the length of 6-car formation. Each Depot will comprise of an inspection shed consisting an inspection bay and a workshop bay.

0.10 ENVIRONMENT IMPACT ASSESSMENTS AND MANAGEMENT

A detailed Environmental Impact Assessment Study has been carried out along the proposed alignment. As a part of this study, comprehensive environmental baseline data was collected. Both positive and negative impacts of the project were assessed in detail. The project has many positive environmental impacts like reduction in traffic congestion, saving in travel time, reduction in air and noise pollution, lesser fuel consumption, lesser road accidents etc. However, the project has some negative impacts especially during implementation of the project. An important environmental consideration of this project is that neither any forest area nor any plants/ trees of endangered species exist along the proposed alignment, though 685 trees will need to be uprooted. A few residential/commercial structures are affected. To minimize the negative environmental impacts, an Environmental Management Plan has been drawn up.

0.11 COST ESTIMATES

The overall capital cost for PCMC - Swargate Corridor, at November 2015 price level, works out to **Rs.5333 crores**, excluding taxes and duties, but including general charges & design charges @ 5% on all items except land and 3% contingencies on all items. The abstract capital cost estimates are shown at Table below:-

**Table 0.10 - Capital Cost Estimate of PCMC – Swargate (Corridor I)
(November 2015 Price Level)**

Corridor I (PCMC-SEWARGATE SECTION)					
Total length = 16.589 km, UG= 5.019 km (TBM = 4.114 km, C&C = 0.905 km), Elv = 11.570 km					
Total Station = 15 nos, UG = 6, Elv =9					
S. No.	Item	Unit	Rate	Qty.	Amount (Rs. in Cr.)
					Without taxes
1.0	Land				503.94
1.1	R & R incl. Hutments etc.	R Km	3.55	17.589	62.40

	Sub Total (1)				566.34
2.0	Alignment and Formation				
2.1	Underground section by T.B.M excluding station length (260m each)	R. Km.	150.00	3.074	461.10
2.2	Underground section by Cut & Cover excluding Station length (260m each)	R. Km.	100.00	0.385	38.50
2.3	Elevated section including station length	R. Km.	33.00	11.570	381.81
2.4	Entry to depot at grade	R. Km.	19.80	1.000	19.80
	Sub Total (2)				901.21
3.0	Station Buildings				
3.1	Underground Station(260 m length) incl. EM works, lifts, escalators, VAC etc.	Each			
a	Underground Station- Civil works	Each	150.00	6.000	900.00
b	Underground Station- EM works etc.	Each	60.00	6.000	360.00
3.2	Elevated stations	Each			
a	Type (A) way side- civil works	Each	26.00	5.000	130.00
b	Type (A) way side- EM works etc	Each	11.81	5.000	59.05
c	Type (B) Way side with signalling-civil works	Each	25.89	2.000	51.78
d	Type (B) Way side with signalling-EM works etc	Each	11.81	2.000	23.62
e	Type (C), Terminal station -civil works	Each	29.01	2.000	58.02
f	Type (c), Terminal station -EM works	Each	11.81	2.000	23.62
3.3	Metro Bhawan & OCC bldg.	LS			
a	Metro Bhawan & OCC bldg.-civil works	LS			56.25
b	Metro Bhawan & OCC bldg.-EM works etc	LS			18.75
	Sub Total (3)				1681.09
4.0	Depot	LS			
a	Civil works	LS			100.00

b	EM works etc	LS			50.00
	Sub total (4)				150.00
5.0	P-Way				
5.1	Ballastless track for elevated & underground Section	R. Km.	7.85	16.589	130.22
5.2	Ballasted track for at grade alignment in depots	R. Km.	3.93	5.000	19.63
	Sub total (5)				149.85
6.0	Traction & power supply incl. OHE, ASS etc. Excl. lifts & Escalators				
6.1	UG Section	R.Km.	15.39	5.019	77.25
6.1	Elevated & at grade section	R.Km.	10.34	12.570	129.98
	Sub total (6)				207.23
7.0	Signalling and Telecom.				
7.1	Sig. & Telecom.	R. Km.	15.73	17.589	276.63
7.2	Automatic fare collection	Stn.			
	a)Underground section	Each	5.41	6.000	32.45
	b) Elevated stations	Each	5.41	9.000	48.67
	Sub Total (7)				357.75
8.0	Misc. Utilities, roadworks, other civil works such as median stn. signages Environmental protection	R. Km.			
a	Civil works+EM works	R. Km.	7.18	16.589	119.15
	Sub Total (8)				119.15
9.0	Rolling Stock	Each	10.60	76.000	805.62
	Sub Total (9)				805.62
10.0	Capital expenditure on security	LS			
a	Civil works	LS			12.00
b	EM works etc	LS			8.00
	Sub Total (10)				20.00
11.0	Total of all items except Land				4391.90
12.0	General Charges incl. Design charges @ 5 % on all items except land				219.60

13.0	Total of all items including G. Charges except land				4611.50
14.0	Contingencies @ 3 %				138.34
15.0	Gross Total				4749.84
Cost without land				=	4750
Cost with land				=	5333

The overall capital cost for Vanaz – Ramvadi Corridor at November 2015 price level, works out to Rs. 2794 crores, excluding taxes and duties, but including general charges & design charges @ 5% on all items except land and 3% contingencies on all items. The abstract capital cost estimates are shown at Table below:-

**Table 0.11 - Capital Cost Estimate of Vanaz – Ramvadi (Corridor II)
(November 2015 Price Level)**

Corridor II (VANAZ-RAMVADI SECTION)					
Total length = 14.665 km, UG= 0 km , Elv = 14.665 km					
Total Station = 16 nos, UG = 0, Elv =15					
S. No.	Item	Unit	Rate	Qty.	Amount (Rs. in Cr.)
Without taxes					
1.0	Land				282.77
1.1	R & R incl. Hutments etc.	R. Km.	3.55	15.665	55.58
	Sub Total (1)				338.35
2.0	Alignment and Formation				
2.1	Elevated section including station length	R. Km.	33.00	14.665	483.97
2.2	Entry to depot at grade	R. Km.	19.80	1.000	19.80
	Sub Total (2)				503.77
3.0	Station Buildings				
3.2	Elevated stations	Each			
a	Type (A) way side- civil works	Each	26.00	12.000	312.04
b	Type (A) way side- EM works etc	Each	11.81	12.000	141.69
c	Type (B) Way side with	Each	25.89	2.000	51.78

	signalling-civil works				
d	Type (B) Way side with signalling-EM works etc	Each	11.81	2.000	23.62
e	Type (C), Terminal station -civil works	Each	29.01	2.000	58.02
f	Type (c), Terminal station - EM works	Each	11.81	2.000	23.62
3.3	Metro Bhawan & OCC bldg.	LS			
a	Metro Bhawan & OCC bldg.-civil works	LS			0.00
b	Metro Bhawan & OCC bldg.-EM works etc	LS			0.00
	Sub Total (3)				610.76
4.0	Depot	LS			
a	Civil works	LS			100.00
b	EM works etc	LS			50.00
	Sub total (4)				150.00
5.0	P-Way				
5.1	Ballastless track for elevated & underground Section	R. Km.	7.85	14.665	115.16
5.2	Ballasted track for at grade alignment in depots	R. Km.	3.93	5.000	19.63
	Sub total (5)				134.79
6.0	Traction & power supply incl. OHE, ASS etc. Excl. lifts & Escalators				
6.1	Elevated & at grade section	R.Km.	10.34	15.665	161.99
	Sub total (6)				161.99
7.0	Signalling and Telecom.				
7.1	Sig. & Telecom.	R. Km.	15.73	15.665	246.37
7.2	Automatic fare collection	Stn.			
	Elevated stations	Each	5.41	15.000	81.12
	Sub Total (7)				327.49
8.0	Misc. Utilities, roadworks, other civil works such as median stn. signages Environmental protection	R. Km.			
a	Civil works+EM works	R.	3.79	14.665	55.57

		Km.			
	Sub Total (8)				55.57
9.0	Rolling Stock	Each	10.60	28.000	296.81
	Sub Total (9)				296.81
10.0	Capital expenditure on security	LS			
a	Civil works	LS			12.00
b	EM works etc	LS			8.00
	Sub Total (10)				20.00
11.0	Total of all items except Land				2261.18
12.0	General Charges incl. Design charges @ 5 % on all items except land				113.06
13.0	Total of all items including G. Charges except land				2374.23
14.0	Contingencies @ 3 %				71.23
15.0	Gross Total				2445.46
Cost without land				=	2445
Cost with land				=	2794

0.12 FINANCIAL VIABILITY, FARE STRUCTURE AND FINANCING OPTIONS

The FIRR of subject metro with central taxes is positive i.e., 6.87% (when PD and other income is not considered) and with PD and additional income the FIRR is 13.60%. Therefore the corridors are recommended for implementation with additional income. FIRR has been calculated without taking in to account the revenue from sale of additional FAR.

Table 0.12 - Fare Structure in 2020-21

Distance in Kms	DMRC Fare as Revised in 2009	Pune Metro Fare (Rs.) in 2020-21
0-2	8	10
2-4	10	20
4-12		30
12-18	12	40
>18	15	50

The funding pattern assumed under government owned SPV model is placed in Table 0.13 as under:-

Table 0.13 - Funding pattern under SPV model (with Taxes & Duties)

Particulars	With Taxes & Duties	
	Amount (Rs/Crore)	% Of contribution
Equity By GOI	1310.00	13.41%
Equity By GOM	1310.00	13.41%
SD for CT by GOM (50%)	644.00	6.59%
SD for CT by GOI (50%)	644.00	6.59%
Grant by Local Bodies	28.50	0.30%
PTA against WORLD BANK AND AIIB Loan @ 0.30% PA	5831.50	59.70%
Total	9768.00	100.00%
SD by GOM for Land including R&R cost and State taxes	302.20	
Subordinate Debts for Land including R&R cost and State Taxes From ULB	1210.80	
Total	11281.00	
Additional PTA for Interest during Construction (IDC)	139.00	WORLD BANK AND AIIB Loan @ 1.40%
Grand Total	11420.00	

In addition to the above, State Taxes of Rs.630 crore on completion cost basis has to be either reimbursed or exempted or to be provided as subordinate debts by state government

Property Development

PMC has intimated that they will make available 6.4435 Hectare of the land , the plots already identified by them and given in Civil Engineering chapter. In addition, it is assumed that air space of 4 Hectare of the Depot land in Agriculture university area will also be commercially exploited for supporting this project. Thus, 10.4435 hectares land will be developed with the involvement of established Developers. It is assumed that FAR of 4 will be allowed for the commercial exploitation of these plots for the project. It is expected that it may yield up front receipt of Rs.600 Crores. Also, the property development models can be designed in a way that not only the upfront receipts but also the regular revenue in the development of lease rentals can be ensured to supplement the fare box collection and reduce the fare structure. PMC has confirmed that additional FAR of 4 can be adopted for calculating the earnings from Property Development.

Earnings from FSI

In addition to the above, earnings from sale of additional Floor Area Ratio (FAR) along both the corridors are also possible. The rate of sale of additional FAR has been taken as Rs. 10000 per Sq. m. These earnings from the densification of the corridor and sale of Floor Surface Index (FSI) have been taken as recurring income during the first four years of operation. The details of estimated earnings from additional FSI are as under: -

Total length of corridor X 50% (% length of the corridor possible for densification) X 1000 X 60% X additional FAR of 4 = 31.254 KM X 50% X 1000 X 60% X 4 X 10000 = **Rs. 37505** crore. It is felt that this amount will not come in one year or two but may be achievable only in about 20 years time. However, for this project only **Rs. 2000** crores earnings from sale of FSI have been assumed in the first four years of construction period @ 10%, 30%, 30% & 30% (2000 crores) each year respectively. However the income from sale of FSI has not been taken into account while working-out FIRR.

Recommendation

(B) The FIRR of Subject Metro with taxes and considering additional sources of revenue through (i) additional development charges and (ii) surcharge of 1% on registration fees on sale of Properties as brought out in table 12.9.1(b) is 13.60%. Therefore the Pune Metro Project Phase I comprising Corridor 1 and Corridor 2 is recommended for implementation.

The total fund contribution of GOI & GOM under various alternatives is tabulated in Table 0.14

Table 0.14 - Fund Contribution of GOI & GOM

(Rs. In crore)

Particulars	SPV Model	BOT
GOI	1954.00	1954.00
GOM & State's/ULB other contributions	3495.50	5559.00
Total	5449.50	7513.00

The funding pattern assumed under SPV model is depicted in the pie chart i.e., Figure 0.1 as under: -

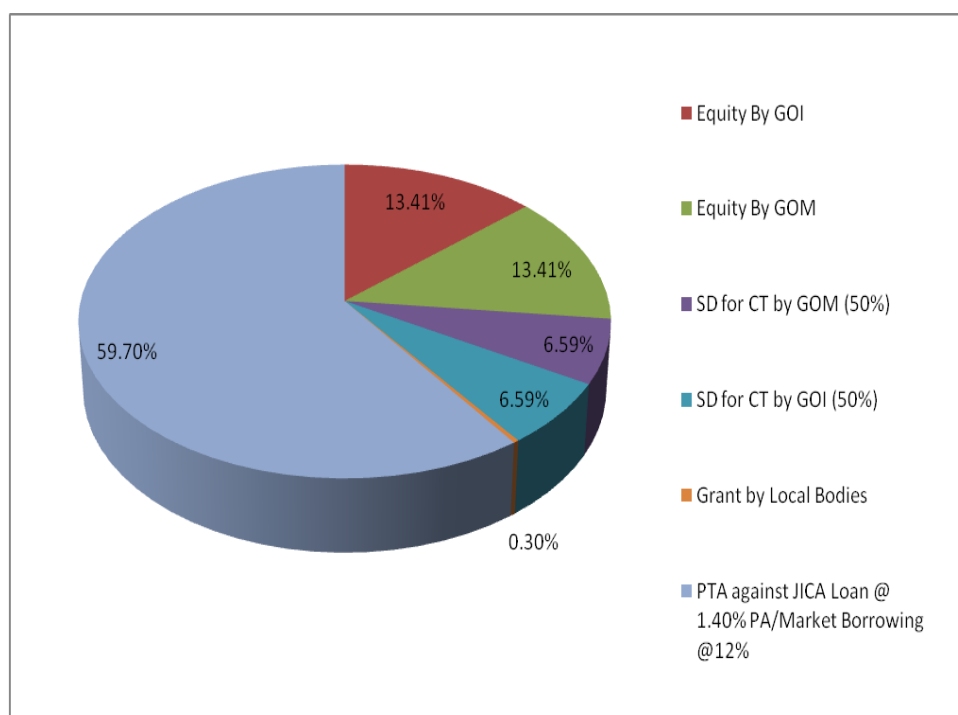


Figure 0.1 Funding Pattern - SPV Model

0.13 ECONOMIC ANALYSES

After generating the cost and benefit stream table, values of economic indicators are derived and are presented in table 13.10. Project period is 2016-2047, EIRR at present rate is found to be **16.32%** and B/C ratio as 3.24 and with 12 % discount, EIRR is 3.85% and B/C ratio is 1.41. EIRR (fixed cost excluding all taxes-economic value) is found to be 21.53% and B/C ratio as 9.73 and with 12 % discount, EIRR is 8.51% and B/C ratio is 2.34.

0.14 IMPLEMENTATION PLAN

Way Forward for Implementing Pune Metro Project

On receipt of the Detailed Project Report, following action will be required for implementing the Corridor-1 & Corridor-2 of Pune Metro:

- Approval to the Detailed Project Report to be taken from Maharashtra State Government (Cabinet approval).
- The DPR to be forwarded to the Ministry of Urban Development, Planning Commission and Finance Ministry with the request for approving the Metro project and for financial participation through equity contribution in the SPV.
- Signing of an MOU between Maharashtra State Government and Government of India giving all details of the Joint Venture bringing out the financial involvement of each party, liability for the loans raised, the administrative control in the SPV, policy in regard to fare structure, operational subsidy, if any, etc.
- Set up a Special Purpose Vehicle (SPV) for implementing the project and for its subsequent Operation & Maintenance.
- The Government of India is considering enactment of a Central legislation to give legal cover for construction and maintenance of Metros in other cities. Under this Central enactment, State Governments will have to frame the rules and procedures for implementation.
- The State Government should formulate the funding plan for executing this project and get the same approved by the Government of India. The loan portion of the funding will have to be tied up by State Government in consultation with the Government of India.
- The Government should freeze all developments along the corridors suggested. For any constructions within 50 m. of the proposed alignment a system of 'No Objection Certificate' should be introduced so that infructuous expenditure at a later stage is avoided.

Organisational Set-Up of PMMRC

The PMMRC Organisation, as stated earlier, should be very lean but effective. It will consist of a non-executive Chairman, a Managing Director with full Executive Powers (in Schedule 'A') and three Functional Directors (in Schedule 'B') including Director (Finance). All the three Functional Directors will be full members of the Management Board. The Directors will be assisted by Heads of Departments in each of the major disciplines and they in turn will have Deputy Heads of Departments. The organisation should be basically officer-oriented with only Personal Assistants and Technical Assistants attached to senior officers by eliminating unproductive layers of staff such as Peons, Clerks, etc. We strongly recommend that the total organisational strength is limited to 45 to 50 eliminating too many tiers to enable faster decision-making. An organizational chart for MMRC is enclosed.

It is necessary for the PMMRC officers to get exposed to the Metro technology and Metro culture through study tours of some of the selected foreign Metros and Delhi/Calcutta Metros.

Implementing a metro project in a congested metropolis is indeed a challenge. In sheer size, magnitude and technical complexity there are no parallels to metro projects. Further, these projects are to be carried out in difficult urban environment without dislocating city life, while at the same time preserving the environment. The project involves integration of a number of complex technical systems – some of these technologies used in these systems are totally new to the country – each one of which is a major project by itself. Interfacing various system contracts is a difficult and highly skilled exercise. Side by side, timely and adequate funds have to be assured for implementation and lands, without encumbrances, have to be taken possession of in time. Clearances from the local authorities have to be taken permission to cut trees, diversion of utilities, management of road traffic, etc., all of which will call for an efficient and competent project implementing agency.

Metro projects cannot be executed the way Government agencies execute projects in this country. Timely completion is very important to safeguard the financial viability. Competent and skilled technical personal to man such an organisation are difficult to mobilize. In fact such experienced persons are not readily available in the country. Being a rail based project, for most of the systems such as rolling stock, signaling, telecommunication, traction power supply, etc., persons with railway background would be necessary.

Since PMMRC will not have the required expertise and experienced manpower to check and monitor the General Consultants it may be necessary to engage Prime Consultants from the very start of GC's assignment who will do this job on behalf of PMMRC. Delhi Metro Rail Corporation can be considered for being appointed as Prime Consultant to PMMRC.

Implementation through SPV

Once the SPV is formed, it has to take action for appointment of General Consultants for project management including preparation of tender documents. Till the General Consultants are in position, PMMRC should appoint an interim Consultant for all preliminary and enabling jobs such as land acquisition, detailed design of civil structures, utility diversions, etc.

A suggested project implementation schedule is given below. The proposed date of commissioning of the section with suggested dates of important milestones is given in **Table 0.15**.

Table 0.15 - Implementation Schedule through SPV

S. No.	Item of Work	Completion Date
1.	Submission of Final DPR to State Govt.	D
2	Approval of DPR by State Government	D+30
3	Appoint interim Consultant for preliminary works	D+30
4	Approval of Project by Empowered Committee	D+60
5	Sanction of Project by EGOM.	D+90
6	Appoint General Consultant	D+270
7	Tendering, Execution of works and Procurement of equipments, coaches and installations	D+300 to D+1600
8	Testing and Commissioning	D+1600 to D+1700
9	Revenue Operation	D+1700

Both corridors can be divided into sections for the purpose of commercial opening in stages. In first stage, line No. 2 (completely elevated) and elevated portion of Corridor 1 up to ShivajiNagar Station (Underground) will be opened. Both Depots should also be available for commercial operation.

Concessions from Government

Metro rail projects need very heavy investment. Loans have invariably to be taken to fund a part of the capital cost of the projects. These projects yield low financial internal rate of return. With reasonable fare level, servicing of these loans often pose problems. To make the project financially viable, therefore, the fares need to be substantially increased to socially un-acceptable levels. This results in the ridership coming down significantly, as it is

sensitive to increases in the fare level. Thus the very objective of constructing the metro rail system to provide an affordable mode of mass travel for public is defeated. It, therefore, becomes necessary to keep the initial capital cost of a metro project as low as possible so that the fare level of the metro system can be kept at reasonable level

Posting of OSD

Since sanction of Pune Metro may take some time, It is recommended that Maharashtra State Government should urgently post an Officer on Special Duty (OSD) with adequate powers to process and persue sanction for this project and to take preliminary steps required for its implementation.

Need For Dedicated Fund For Metro Projects

We also strongly recommend that the State Government start building up funds for the project through dedicated levies as has been done by other State Governments notably Karnataka.

To enable the State Governments to provide their share of equity in the Special Purpose Vehicles set up for such projects, it would be necessary to constitute a Special Metro Fund at the State Government level. The State Governments should resort to imposition of dedicated levies for raising resources for these Funds. Areas where such dedicated levies are possible is given below:

- A 50% cess on the tax levies for registration of road vehicles.
- A Surcharge on fuel (petrol, diesel).

The above two levies would also assist to discourage the use of personalized vehicles and encourage the use of public transport, which would not only reduce the pollution level in the city but also reduce traffic congestion on the road.

- Metro Tax @ 2% on pay rolls of all establishments having more than 100 employees. Such cess is in existence in a number of Western countries for raising resources for metro rail. The employer's benefit a good deal by good Metro System.
- Surcharge @ 10% on luxury tax on the earning of all Star Hotels. At present level, the luxury tax is 10%. The surcharge will raise the level to only 11%. Chinese cities have adopted this scheme.

0.15 CONCLUSIONS AND RECOMMENDATIONS

Pune has witnessed enormous industrial growth during the last 10 years. Rapid urbanization in the recent past has put the city's travel infrastructure to stress. With a large

number of units have come up both in small scale as well as in heavy & medium scale industry, etc., traffic in the city is expected to shoot up. Being thickly populated area, Pune's traffic needs cannot be met by only road-based system.

The existing urban transport system of Pune City which is road-based has already come under stress leading to longer travel time, increased air pollution and rise in number of road accidents. With projected increase in the population of the city strengthening and augmenting of transport infrastructure has assumed urgency. For this purpose provision of rail-based Metro system in the city has been considered.

Studies have brought out that a Medium Metro with carrying capacity of about 25,000 phpdtd will be adequate to meet not only the traffic needs for the present but for the future 30 to 40 years also. A Medium Metro System consisting of two Corridors namely (i) PCMC – Swargate Corridor (16.59 km) and Vanaz - Ramvadi Corridor (14.67km) at an estimated completion cost of **Rs. 10700.00** crores (Central taxes & duties) to be made operational has accordingly been recommended

After examining the various options for execution of Pune Metro Project, it has been recommended that the project should be got executed at DMRC Pattern.

(C) While the Financial Internal Rate of Return (FIRR) for the Project has been assured as 13.60% without additional Property development but with additional revenue from development charges and 1% surcharge on Registration fees on the sale of Properties. The Economic Internal Rate of Return (EIRR) works out to 16.32%

To avoid delays in processing the clearance for the Project, It is suggested that immediately on receipt of the DPR, the State Government should approve it 'in principle' and forward the DPR to the Secretary, Ministry of Urban Development, Government of India, advising the GOI of the State Government's intention to take up the Project on DMRC pattern requesting for the latter's "in principle" clearance to go ahead with the Project.

Since the SPV to be set up to get the project implemented and initially the SPV may lack in expertise, it will be necessary to engage Interim Consultants for the first one year who will do this job on behalf of the SPV in preparation of land plans, transferring the alignment from drawing to the ground, fixing the contracts for some of the selected elevated packages and depots. Interim consultant will also help in finalization of General Consultants.

To keep a check on the work of General Consultants and to ensure that the Metro is being constructed to meet the appropriate specifications and safety standards, the SPV will also need to engage the services of Prime Consultants for having the check on the supervision of General Consultants and render the necessary advice to SPV on the various technical matters.



Chapter -1

Introduction



- 1.1 Back Ground
- 1.2 Study Area
- 1.3 Demographic Profile
- 1.4 Present Study



CHAPTER - 1

INTRODUCTION

1.1 BACKGROUND

Pune is well known as the 'Queen of Deccan' due to its scenic beauty and rich natural resources. Besides, it is famous for its religious and historical places. Pune city is known in the world map because of its educational, research and development institutions. The district also has an importance as an important military base. Pune is the most industrialized district in western Maharashtra and a famous IT hub in the country. Pune exemplifies an indigenous Marathi culture and ethos, in which education, arts & crafts and theaters are given due prominence. Pune is the cultural capital of Maharashtra. It is the birth place of the poet-saint Tukaram. It is the home of great freedom fighters like Bal Gangadhar Tilak, Agarkar and Gopal Krishna Gokhale. Jayant Narlikar, the famous contemporary scientist is from Pune.

1.1.1 Location

Pune district is located between 17° 54' and 19° 24' North latitude and 73° 19' and 75° 10' East longitude. The district has geographical area of 15.642 sq km. The district is bound by Ahmadnagar district on the north-east, Solapur district on the south-east, Satara district on south, Raigad district on the west and Thane district on the north-west. Pune district forms a part of the tropical monsoon land and therefore shows a significant seasonal variation in temperature as well as rainfall conditions. Climate of the western region of Pune is cool whereas the eastern part is hot and dry.

1.1.2 Earthquake Prone Areas

Due to the presence of many structural hills within Pune district, it is likely place for earthquakes. Small south-west side portion of taluka Borand Velha fall under risk zone-IV, which is high damage risk zone. The remaining part of the district falls under zone -III, which is moderate risk zone.

1.1.3 Flood Prone Areas

Most of the talukas in Pune district are flood prone. The rivers likely to cause flooding are rivers - Bhima, Mula, Mutha, Indrayani, Ghod, Mina, Pushpavati, Nira and river Pavana. Due to heavy rainfall, land slide occurs in taluka Ambegaon, Junnar and Mushi.

1.1.4 Road Network

Pune district is well connected with the state capital and surrounding headquarters through road and rail linkages. The road network consists of Express Highways, National Highways, State Highways and Major District Roads. The district has total length of 13,642 km of roads. Following National Highways pass through the district :

1. National Highway No. 4 (Mumbai-Bangalore)
2. National Highway No. 9 (Pune-Solapur-Hyderabad)
3. National Highway No. 50 (Pune-Nashik).

1.1.5 Rail Network

The district has a total rail network of 311 km. Pune and Daund are the two major junction stations. Following are the three main Railway routes pass through the district :

1. Mumbai-Pune-Solapur
2. Pune-Miraj
3. Daund-Baramati.

1.1.6 Air Route

Pune is well connected through domestic airlines with the entire country. The airport located at Lohgaon has recently acquired status of an international airport. Also it is proposed to develop an international air-cargo hub near Khed Tahsil of the district.

1.2 STUDY AREA

The study area has been taken as the area comprising the present Pune Corporation (PMC), Pimpri Chinchwad Municipal Corporation (PCMC) and both the cantonment areas namely Pune and Khadki. The study area also includes the Hinjewadi and surrounding areas where the IT Parks are coming up.

The zoning system of the study area comprises of 53 zones in the PMC area and 38 zones in PCMC area. Pune and Khadki cantonments have been considered as two zones. In addition to 91 internal zones, 13 external zones are considered.

1.3 DEMOGRAPHIC PROFILE

The total population of the study area in 2001 was 35.6 lakhs. The break-up of population is as under:

	PMC	PCMC	Pune Cantonment	Khadki Cantonment	Total
2001	2328349	1083967	80191	77473	35,69,980

The decadal growth in PCMC area is almost 100% in the past 3 decades. PMC area has registered an average decadal growth of around 35% and a decline in population is observed in both the cantonments. The population figures of study area for the base year 2011, and estimated population for the horizon years are as under:

Region	2011	2021	2031
PMC	3115431	4807868	5443642
PCMC	1729320	1915320	2106123
Pune Cantonment	67861	88603	93134
Khadki Cantonment	77417	85600	89977
Total	4992040	6899412	7734907

DMRC has been entrusted with the job of preparation of Detailed project report for about 30 Km. of Metro network in Pune metropolitan Authority which includes the city of Pune and Pimpari Chinchwad, vide the letter No. 9002 dated 05.12.2007 of Pune Municipality.

1.4 PRESENT STUDY

Rapid industrialization and intense commercial developments in the past decades have resulted in steep rise in travel demand, putting Pune's transport infrastructure to stress. With the projected increase in the city's population, strengthening and augmenting the existing transport infrastructure has assumed urgency.

Present study has been conducted to identify the main traffic corridors, which will eventually become the routes for running a grade separated Rail based transport system. As technology has vastly improved over the years, underground metro rail system is no more a dream which cannot be translated into reality. Underground metro will be able to connect different parts of the city area with the developed and developing areas and there is no need to recommend detouring to avoid the congested parts of the city.

The Objective of the present study is to identify the best metro corridor network for Pune City. Although the city has relatively low population compared to other metropolitan cities, an advance planning for a modern transportation system for Pune city shall help it to grow in terms of industrialization and commercialization. The objective of the study is to identify the metro corridors for the metro master plan and prioritise the corridors for implementation. This report also deals to find out the sectional loads on different corridors including the station loads for the Phase-I.

1.5 Modification of alignment of Corridor-II between Garware College and Civil Court.

As discussed in the meeting taken by the Hon'ble Central Minister, RTH&S on 09.09.2015, the alignment of Corridor-II has been modified avoiding Jangli Maharaj Road and run along the left bank of Mutha River between Garware College and Civil Court. Due to this modification, one more station near Sambaji Park has been proposed for facilitating more people to use the Metro system. The length of this corridor has slightly reduced by about 261metre. The revised cost of both the corridors has been arrived at the price level of today (November, 2015) and Financial Internal Rate of Return (FIRR) & Economic Internal Rate of Return (EIRR) calculated. Necessary modifications in Civil Engineering Chapter and Executive Summary have also been made.

Chapter - 2

Traffic Study



- 2.1 Study Area and Traffic Zoning
- 2.2 Methodology for Ridership Forecast
- 2.3 Secondary and Primary Data Collection
- 2.4 Travel Demand Model Development
- 2.5 Forecasting of External Trips and Commercial Vehicle Trips
- 2.6 Traffic Demand Forecasting
- 2.7 Detailed Estimation of Ridership on the Recommended Metro system



CHAPTER - 2

TRAFFIC DEMAND ANALYSIS

2.1 STUDY AREA AND TRAFFIC ZONING

2.1.1 Study Area

The proposed Metro Rail System will essentially serve both PMC and PCMC areas. Therefore, the study area has been taken as the area comprising the present Pune Municipal Corporation area, PimpriChinchwad Municipal Corporation area and both the cantonment areas namely Pune and Khadki. The study area also includes the Hinjewadi and the surrounding areas where the IT Parks are coming up. The study area adopted in the study is similar to the one adopted by CES (2004) but with appropriate modifications as stated above. The map in Fig 2.1 shows the study area. The following sections describe the zoning system, and the details of road and rail networks adopted for Metro Master Plan study.

2.1.2 Delineation of Traffic Zones

The zoning system of the study has been adopted from a previous study namely Integrated Traffic Dispersal System for PMC & PCMC carried out by CES in 2004. In addition to the CES zones a few new developments like Hinjewadi IT Park have been added as new zones. Some disaggregation has also been done in larger zones like Pashan. The zoning system of the study area for Metro study comprised 53 zones in the PMC area and 38 zones in PCMC area. Pune and Khadki cantonments have been considered as two zones. The zones in the study area are shown in Fig 2.1. In addition to 91 internal zones, 13 external zones are considered. These external zones represent the catchment of external transport links feeding into the city.



Fig 2.1 Zonal Map of Study Area

2.1.3 Planning Variables

The travel demand in an area depends on land use distribution and its intensity. The variables that describe the travel demand traditionally have been the population, employment and vehicle ownership. The growth of population, employment and vehicles in study area and their projection into the future is described in the following sections.

2.1.3.1 Population

The total population of study area in 2001 was 35.6 lakh (more than thrice the 1971 population of 10.7 lakh). This data is given in Table 21.

Table 2.1 - Population Growth in Study Area

	PMC	PCMC	Pune Cantonment	Khadki Cantonment
1961	595762	46031	65838	58496
1971	856105	83542	69451	65497
1981	1203351	220966	85986	80835
1991	1566651	517083	82139	78323
2001	2328349	1083967	80191	77473

The decadal growth in PCMC area is almost 100% in the past three decades. PMC area has registered an average decadal growth of around 35% and a decline in population has been observed in both the cantonments

The base estimates of population for the horizon years are based on RITES (1998) study. An equivalency has been established in the form of Zonal equivalency factors between RITES zoning system and Zoning system adopted for this study for both population and employment. A lot of modifications have been done to the RITES estimates to incorporate the dynamics of the development. It has been noticed that the population of PMC has been underestimated by RITES and the population of PCMC has been overestimated. This finding was the result of validation of RITES forecasts using 2001 population. Appropriate diminishing compound annual growth rates have been applied to counter these findings. A growth rate varying from 5 % in 2001 to 1 % in 2031 has been used for PMC and similarly a growth rate varying from 9 % in 2001 to 1 % in 2031 has been adopted for PCMC. The aggregate population of PMC in the year 2031 was limited to the PMC forecast of 56.57 lakh as per the City Development Plan 2006-2012. The population of the cantonments was considered to remain constant, keeping in view the steady decline in the past decades. The forecasts were made in terms of gross population of PMC, PCMC and Cantonments separately. The aggregate forecasts thus obtained were apportioned to individual zones as per their observed incremental growth. The proposed residential development in Hinjewadi area in PCMC has been appropriately considered in estimating the population of the zones

containing the area. The estimated population figures of study area for the base year 2008, and the horizon years are given in **Table 2.2**.

Table 2.2 - Estimated Population in Different Areas of Study Area

Region	2008	2011	2021	2031
PMC	3372919	3756345	4807868	5443642
PCMC	1446142	1591873	1915320	2106123
Pune Cantonment	83046	84292	88603	93134
Khadki Cantonment	80232	81435	85600	89977

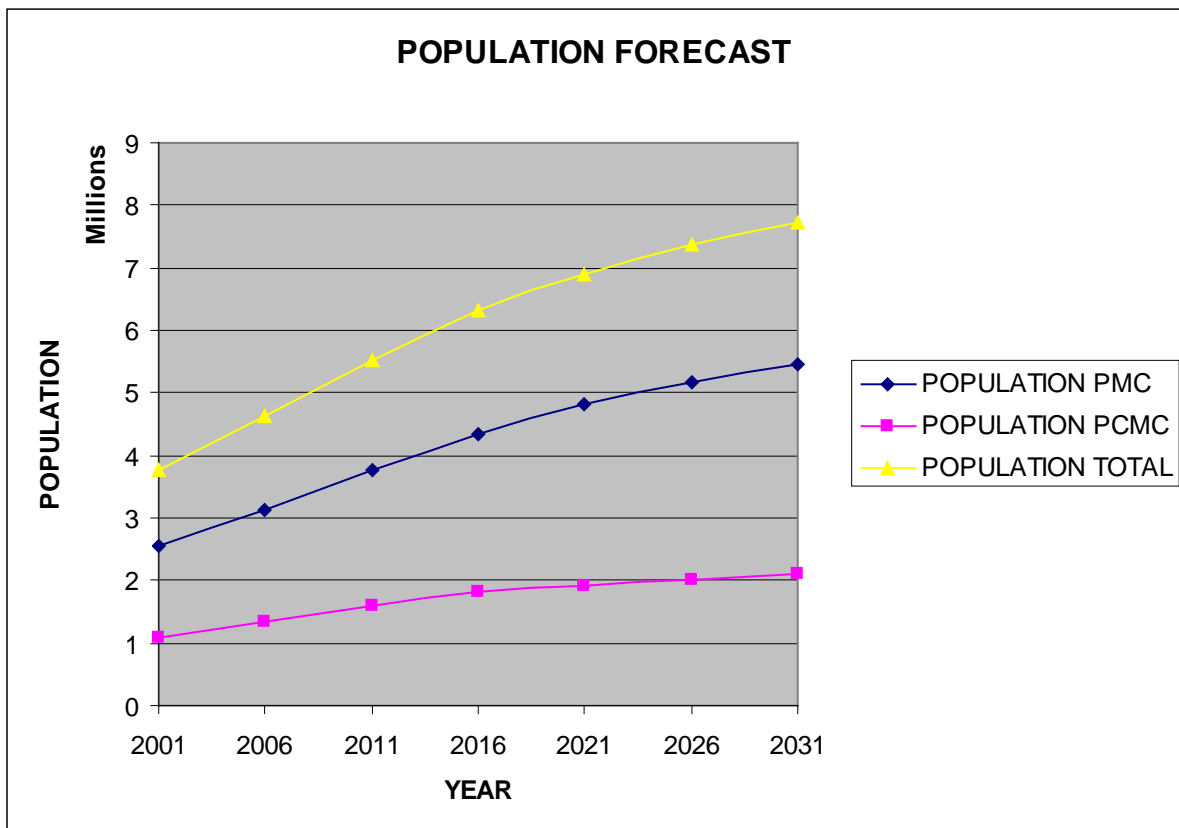


Fig 2.2 - Population projections of different areas of Study Area

Since this study was initiated in year 2008, the same is taken as base year. Estimates of traffic on potential Metro lines are required over a 20 - 30 year period from the year of opening to traffic for the purpose of financial and economic analysis. Therefore the horizon years are kept as 2011, 2021 and 2031.

2.1.3.2 Employment

The aggregate employment data of study area was obtained by assuming worker participation rates of 32%. The adoption of 32 % was justified by both Census 2001 and City Development plan. The aggregate forecasts thus obtained were distributed amongst the individual zones as per their present employment levels. Modifications have been done in view of the recent IT developments as the RITES study did not witness the IT boom in Pune. A proxy index for employment has been developed from the HIS data and has been used to moderate the Zone wise Employment values. A lot of change has been observed in the recently developed zones like Hinjewadi, Talwade, Hadapsar and Yerwada and the changes have been incorporated in the respective zones. The changes incorporated in view of the IT boom are displayed in Table 2.3 The aggregate forecasts of employment are given in Table 2.4 and the same is represented in **Figure 2.3**

Table 2.3 - Additional Employment due to new developments

Area	2008	2011	2021	2031
Rajiv Gandhi InfoTech Park Hinjewadi Phase I	21750	21750	21750	21750
Rajiv Gandhi InfoTech Park Hinjewadi Phase II	19075	27250	54500	54500
Rajiv Gandhi InfoTech Park Hinjewadi Phase III SEZ	7000	17500	56000	70000
Rajiv Gandhi InfoTech Park Hinjewadi Phase IV	0	10000	70000	100000
Kharadi Knowledge Park	6750	6750	6750	6750
Talawade InfoTech Park	6563	9375	18750	18750

Table 2.4 - Employment in Study Area

YEAR	EMPLOYMENT
2001	1207040
2006	1522845
2011	1846476
2016	2161567
2021	2404298
2026	2571595
2031	2709490

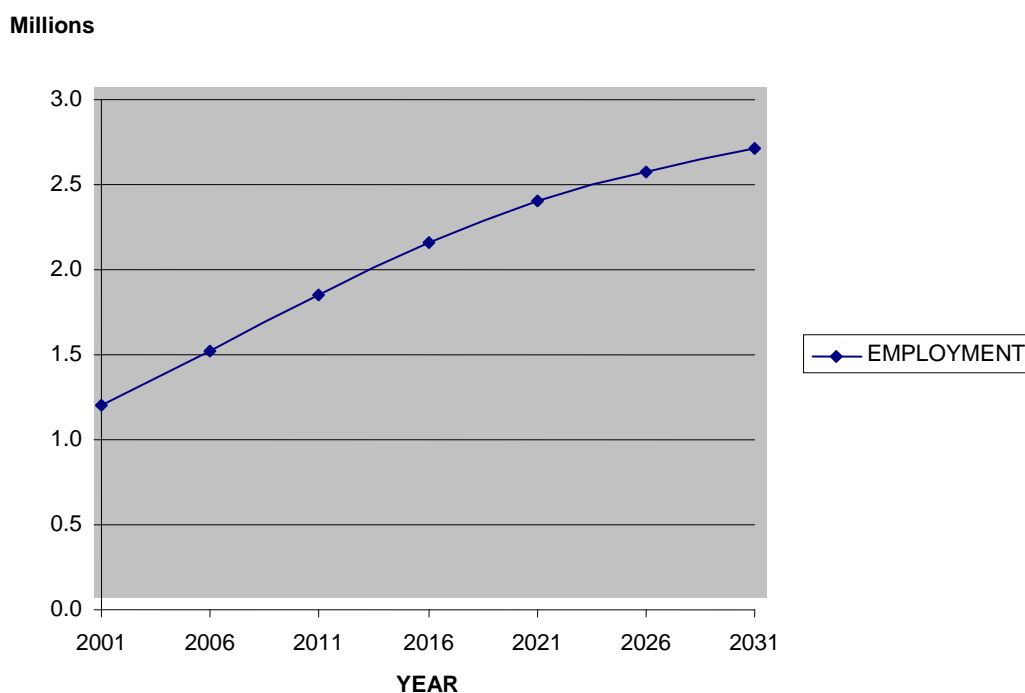


Fig 2.3- Employment Projections for Study Area

2.1.3.3 Vehicle Ownership

The data on private vehicles was obtained from the Road Transport Office in Pune. This data is available for two regions, namely, PMC, and PCMC. The classified number of vehicles (all types) was collected from 1993 onwards. It was observed that the number of private vehicles per thousand people is growing steadily. This clearly shows the inclination of people towards private vehicles. The trend is also influenced by the income level and the state of public transport in Pune. The vehicle ownership characteristics of PMC and PCMC were found to be very distinct and thus modeling has been done differently for both the areas. The number of two wheelers and cars per thousand populations has been taken as proxy explanatory variables for Trip Productions. The registered vehicles in PMC and PCMC areas are given in Table 2.5 and Table 2.6. The projected vehicle ownership and estimated numbers of vehicles in PMC and PCMC is also given in 2.5 and 2.6.

Table 2.5- PMC Motor Vehicle Statistics

Year	PMC				
	Two wheelers	Cars	Population	TW/1000	CAR/1000
1993	235601	29159	1752762	134	17
1994	248398	31574	1845768	135	17
1995	271355	35545	1938873	140	18
1996	313242	40728	2031929	154	20
1997	351538	48439	2124873	165	23
1998	434000	71069	2228672	195	32
1999	490411	82513	2332471	210	35
2000	554155	95799	2436270	227	39
2001	670982	95950	2540069	264	38
2002	724952	105118	2655515	273	40
2003	781541	117231	2770962	282	42
2004	844326	135092	2886408	293	47
2005	922270	160448	3001855	307	53
2006	1021000	211235	3117301	328	68
2007	1189818	231288	3245110	367	71

Table 2.6- PCMC Motor Vehicle Statistics

Year	PCMC				
	Two Wheeler	Car	Pop	TW/1000	CAR/1000
1993	41715	2998	641526	65	5
1994	46610	3927	703715	66	6
1995	53714	4642	765970	70	6
1996	58274	4721	828192	70	6
1997	66061	6725	890339	74	8
1998	88323	7269	936321	94	8
1999	104627	9026	982303	107	9
2000	123940	11208	1028285	121	11
2001	146819	13917	1083967	135	13
2002	173921	17281	1126381	154	15
2003	206026	21458	1178495	175	18
2004	244057	26645	1230610	198	22
2005	289108	33085	1282724	225	26
2006	342476	41083	1459955	235	28
2007	424379	61986	1698215	250	37

Table 2.7- Projected Vehicle Ownership in PMC and PCMC

YEAR	PMC		PCMC	
	TW/1000	Cars/1000	TW/1000	Cars/1000
2001	257	42	152	17
2011	391	86	305	45
2021	437	124	404	88
2031	447	141	438	124

Table 2.8- Estimated Numbers of Private Vehicles in PMC and PCMC

YEAR	PMC		PCMC	
	Two Wheelers	Cars	Two Wheelers	Cars
2001	653043	106027	163285	18368
2011	1467977	323255	476675	70093
2021	2099333	594597	740648	161373
2031	2434606	769605	879090	248390

2.1.4 Highway and Public Transport Network

Separate networks were developed for public and private modes. In case of public transport network, the speed on road links was appropriately adjusted to account for the delay at bus stops. The networks for private, public and IPT modes were coded as per the requirement of Cube-TRIPS software. All the operating bus routes available in Pune Metropolitan area have been coded appropriately with their characteristics. The rail network links were also included in public transport network. Therefore, the public transport network considered in the present study is essentially a composite network comprising of road and rail links, and in future scenarios they include Metro/LRT networks also. The routes for IPT modes, viz., 3 seater autorickshaw and 6 seater autorickshaw were also coded on the public transport network. The private vehicle network (two wheeler and car) considered is the road network. The network for private modes is taken as the network for goods (commercial) vehicles also by incorporating the existing restrictions of freight vehicular movements. Appropriate provisions were made in basic network to account for the proposed and / or possible changes in networks in future years.

The network developed for public transport consists of all road links, suburban rail links, BRT links and future metro links along with the routes coded on them.

All the bus routes were coded on the road network by obtaining the information on all the routes operated by PMT and PCMT from PMPML.

The data on rail links were obtained from the Railways in Pune for preparing the rail network. The Central railways operate suburban trains from Pune station to Lonavala serving 15 stations along its route at an average frequency of 55 min.

2.2 METHODOLOGY FOR RIDERSHIP FORECAST

The travel demand analysis that is performed is based on the secondary data collected in previous similar studies and on the extensive primary data collected exclusively for this study. CES (2004) study is the starting point for this present modeling exercise. The methodology adopted for forecasting traffic volume on Metro corridors consists of the following four steps.

1. Generation and Validation of base year OD Matrices
2. Development of Travel Demand Model
3. Horizon year Travel Demand Forecasts
4. Ridership Estimation on potential Metro Corridors

The following sections briefly describe each of these steps.

2.2.1 Generation of Base Year OD Matrices and Travel Pattern

This process starts with the Home Interview Survey data as input. The data collected from HIS has been checked for bias and the necessary bias correction was applied and expansion factors have been computed. Thus the expanded partial OD matrices were obtained. OD surveys conducted at outer cordon were pooled in to get the OD matrices with all trips. The matrices were loaded on to the network and the assigned values were compared with the ground counts to validate the Matrices. The entire process is shown in Figure 2.5.

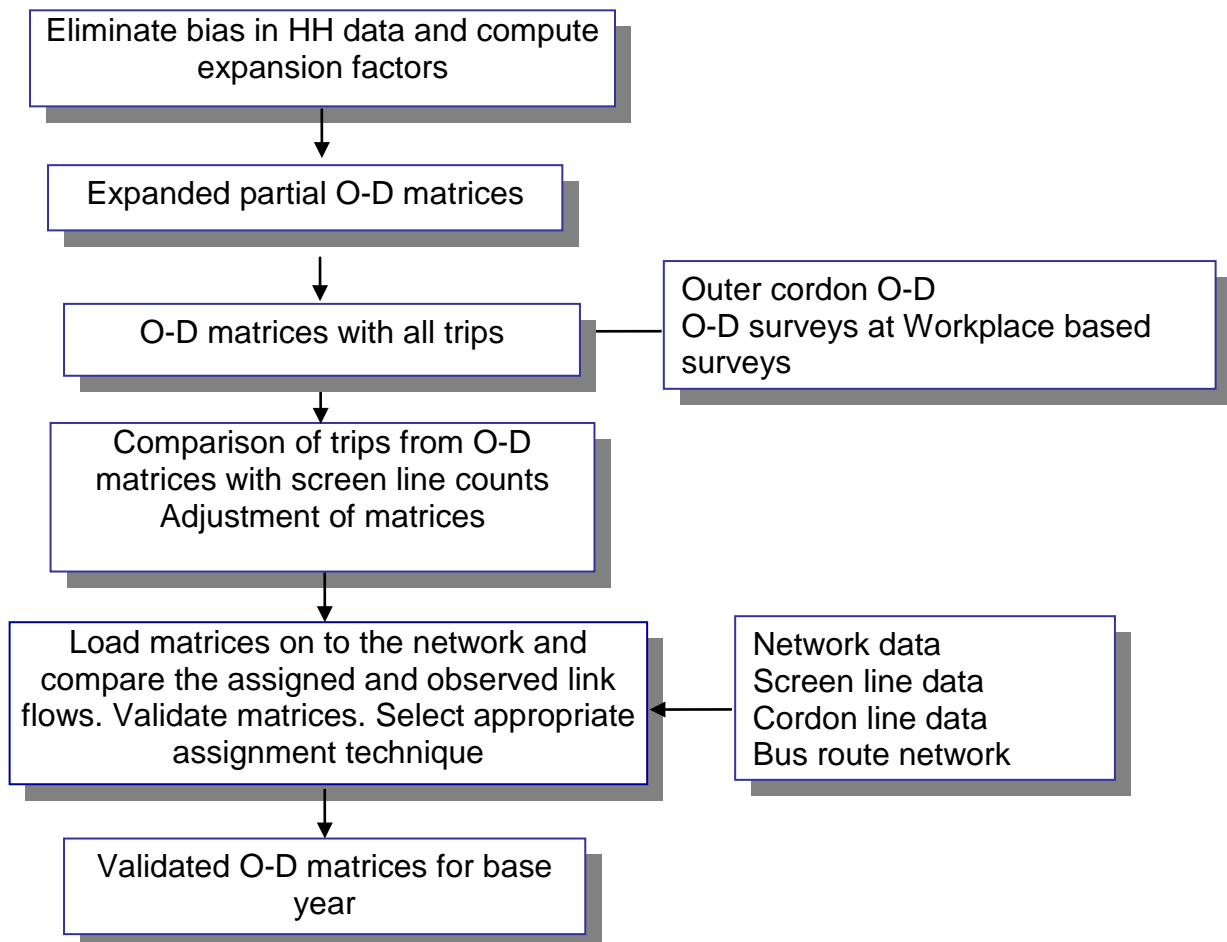


Fig. 2.4

2.2.2 Development of Travel Demand Model

Using the planning variables and validated total O-D matrix for base year (2008), trip end models are calibrated for total internal passenger travel. A single gravity model is calibrated using the validated trip ends and skims (generalized cost) obtained from assignment process as the seed values. The revised skims obtained after successive modal split and traffic assignments will be used to calibrate the gravity model.

A binary logit, modal split model will be devised, to determine the share of public transport and private vehicles. The model will be mainly based on the transport system attributes. The *Public transport matrix* will include the person trips performed by bus, rail, auto and taxi, while the *Private vehicle matrix* will include person trips by car and two-wheeler. The cost skims that will be obtained from the assignment will be used to calibrate the mode choice model.

The peak hour public transport passenger matrix will be assigned to the public transport network, which includes a) Bus network (prepared by coding all the PMPML bus routes), b) Intermediate Public Transport (IPT) routes on the road network and c) Rail network with all the existing links. The public transport assignment will be based on generalized time, which is a combination of In-Vehicle Travel Time (IVTT), Waiting Time (WT), No of Transfers (TR), Fare and Discomfort in time units. The parameters of this generalized time will be obtained from Stated Preference Survey.

There are two important steps in public transport assignment. These are **path building** and **loading trips** on these paths. The purpose of path building is to identify all reasonable paths between zones and provide associated travel information in generalized time, so that the proportion of trips using each path may be calculated at the loading stage. Between any pair of zones, the maximum number of trips will be loaded on to the best path. The other paths with longer generalized times will be loaded with fewer trips. The proportion of trips to be loaded will be calculated on the basis of a logistic choice function based on generalized time.

The public transport assignment is also required to assign the trips as per the observed modal shares. In order to achieve this, the parameters of the generalized time were fixed based on the values obtained from the analysis of stated preference surveys. After performing the public transport assignment, the assigned flows across the screen lines will be compared with the observed flows.

Highway assignment will be carried out for peak hour, preloading the highway network with peak hour public transport and commercial vehicle flows. The daily public transport loadings are factored by the peak hour flow to daily flow ratios to obtain the peak hour public transport flows. These are converted to PCU's by using appropriate passenger-to-PCU conversion factors. These peak-hour public transport (bus and IPT) and commercial vehicle flows in terms of PCU's will be preloaded on to the highway network before loading the private vehicle passenger OD matrices. The private vehicle passenger matrices will be converted into peak hour PCU units, by using appropriate regional peak hour ratios and passenger-PCU conversion factors, based on observed occupancies at screen lines. A user equilibrium procedure based on generalized cost (sum of vehicle operating cost and time cost) will be used in loading private vehicle matrices.

The public transport network will be revised with the speeds obtained after assigning the private trips. The assignment of public transport trips will be performed on the revised network, and the next iteration of private traffic assignment will be carried out by taking the bus, taxi, auto and truck flows as preloads. This iterative process between PT and private vehicle traffic assignment will be repeated until there is no appreciable change in the link loadings and link costs.

Two skims namely the highway time and highway travel costs will be obtained from the loaded network. The skims obtained will be used for calibrating the gravity model and the modal split-model. The process of distribution, modal split and assignment will be repeated till the OD matrices become stable. The complete model development process is graphically represented in Figure 2.5.

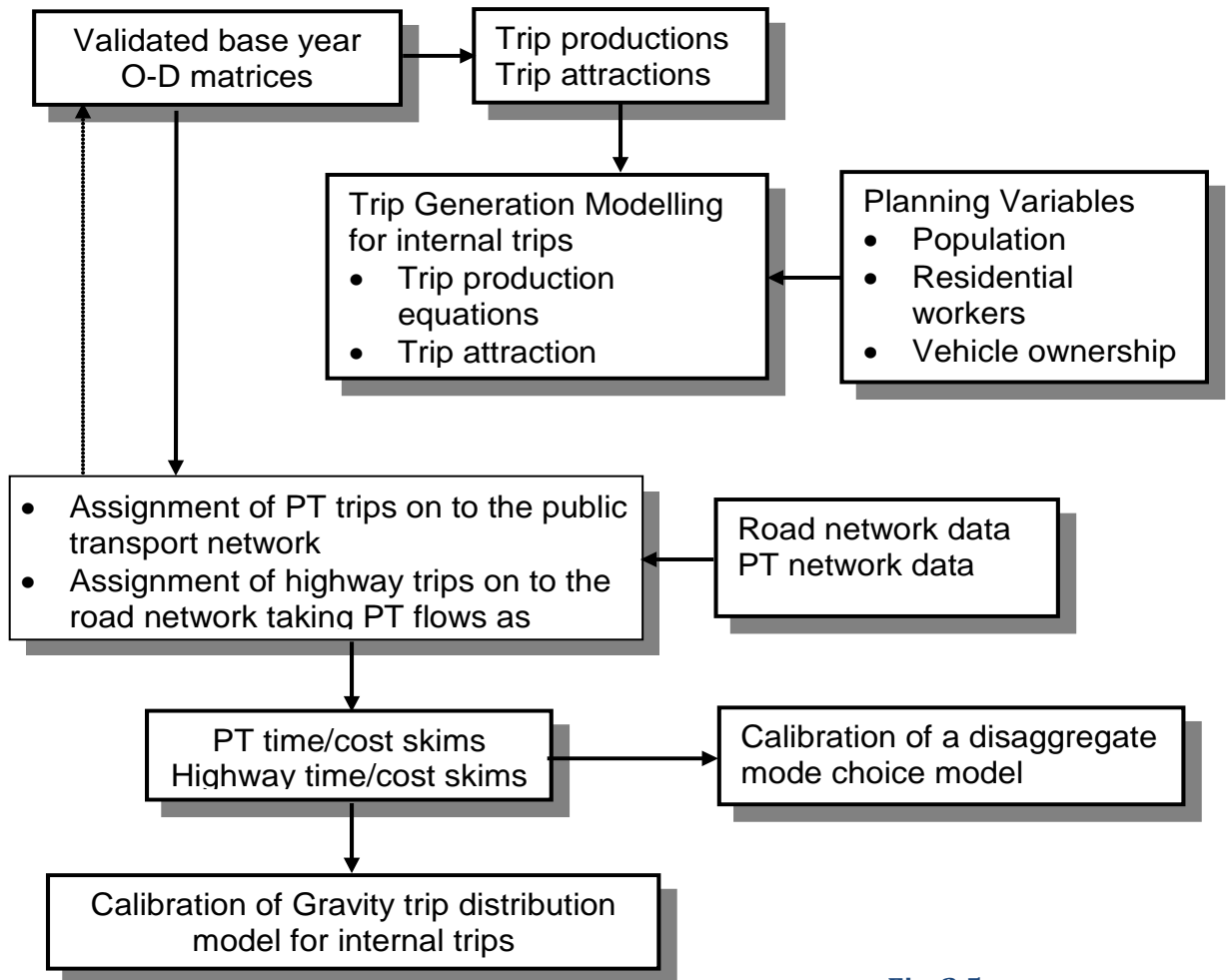
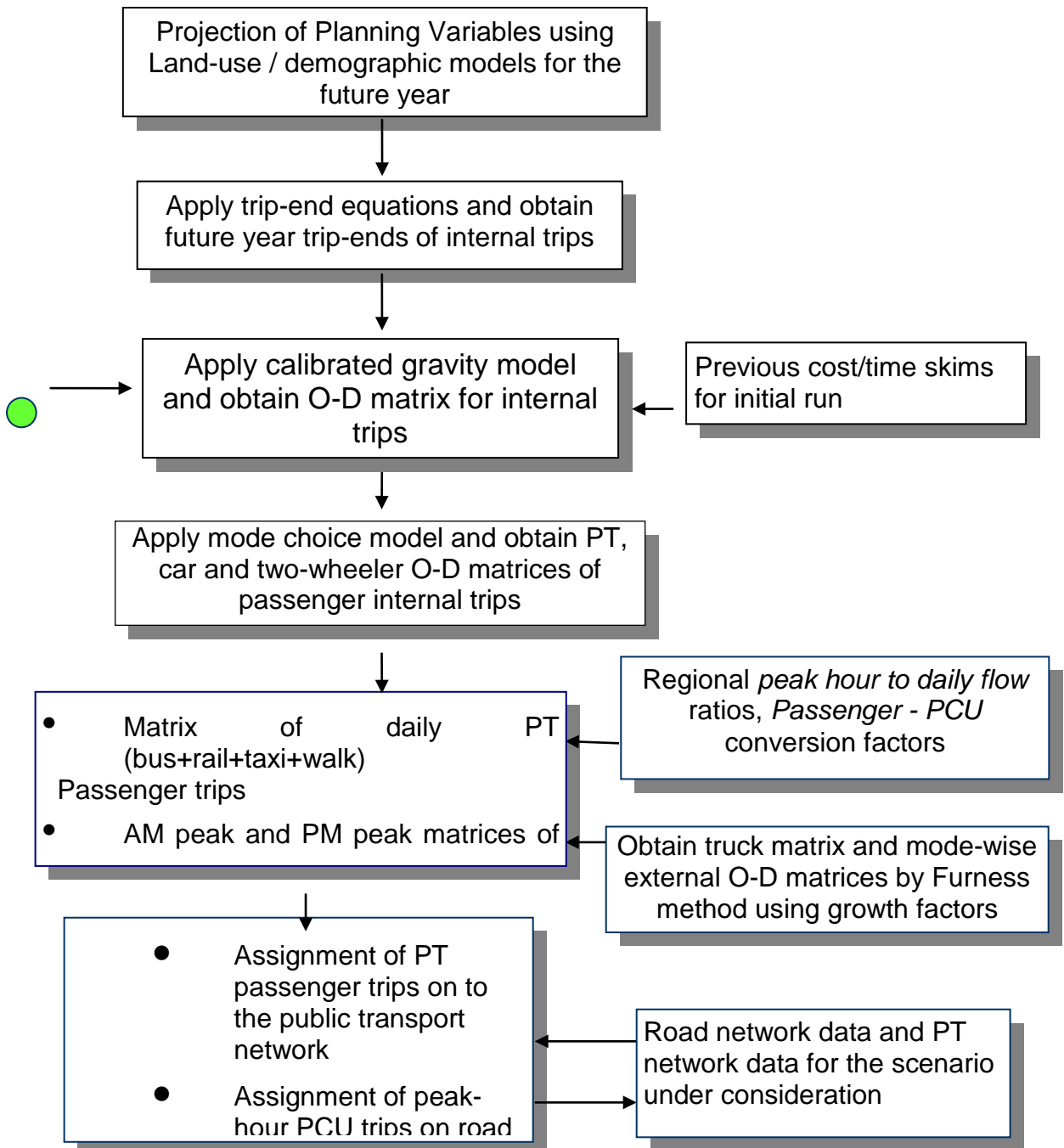


Fig. 2.5

2.2.3 Horizon Year Travel Demand Forecasts

The developed Travel Demand Model is used to forecast the Horizon Year loadings on each mode on all the links. Future forecasts would be done for the Horizon years 2011, 2021 and 2031. Planning variables would be forecasted for Horizon years based on demographics and also with inputs from respective planning agencies. The planning variables of horizon year form the input to the Travel demand model along with the future highway and proposed metro corridors. Trip ends are estimated and are fed into the calibrated gravity model along with base year highway skims. The distributed PA matrix so obtained is fed into the Mode split model and mode wise PA matrices are estimated. This forms the internal portion of the

PA matrix. The external passenger PA portion as well as Commercial vehicle trips are estimated by Furness method and added to the horizon year internal matrices. The combine PA matrix is converted into an OD matrix and is loaded on to the highway and PT networks. Skims obtained from this assignment process are updated in the gravity model and redistribution of trips is done. Mode wise OD matrices are estimated by the updated skims. The final matrices thus produced are loaded on to the network and the cycle is continued till the skims are stable. The procedure is displayed in **Figure2.6**.



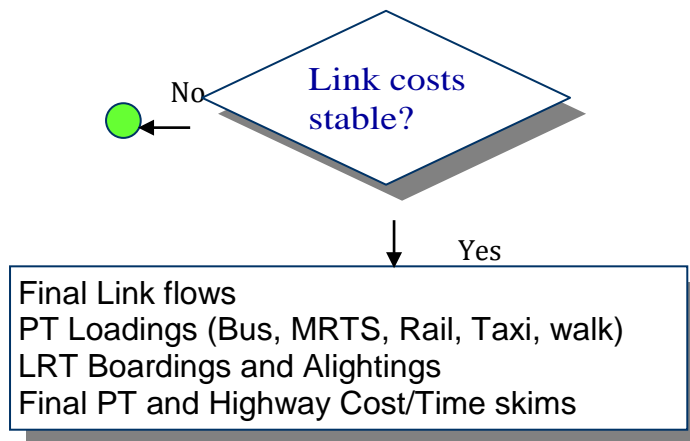


Fig 2.6- Horizon Year Travel Demand

2.3 SECONDARY AND PRIMARY DATA COLLECTION

2.3.1 Secondary data from RITES (1998) and CES (2004) studies

The present study utilizes the data pertaining to planning variables, transportation system, etc. as collected during previous studies conducted by RITES (1998) and CES (2004). The transportation system data such as the highway and public transport networks and system parameters, however, have been updated thoroughly in the present study with the help of Google imagery and some amount of ground verification. The data on planning Variables have also been modified based on census 2001 data and latest employment data incorporating the developments in IT sector in the study area.

2.3.2 Stated Preference (SP) Survey

Stated Preference (SP) is a statement by an individual of his/her liking (or disliking) for one alternative over another. The stated preference technique is used to determine the commuter behaviour with respect to the improved transportation system. In this study, the SP study was used to know commuter's preference and willingness to shift to the proposed Metro rail System. The survey was conducted at workplaces in the potential areas like Shivajinagar, Chinchwad, etc. The workplaces included PMC office, PCMC Office, Tata Motors, Shoppers Stop, ICC trade towers, etc.

SP survey of commuters is required to model the generalized cost of travel as perceived by them along with their willingness to opt for better services. Without any doubt, the proposed Metro Rail System will provide better quality of service in terms of substantial reduction in travel time, more comfort and reliability. Therefore, in order to arrive at the realistic demand for the Metro corridor, it was essential to calibrate the base year models using a generalized

cost of travel comprising waiting time, travel time, travel cost and discomfort. The data sheets used for conducting the SP survey are provided in Annexure to main traffic report.

2.3.3 Traffic Volume counts

In order to establish the base year travel pattern in the study area, in all the traffic volume surveys were undertaken at 20 locations across the 2 screen lines and 14 locations on the cordon line. Cordon stations were established at all those points where the external road links cross the cordon line entering the study area. The details of the location of screen line stations are provided in Table 2.9 and those of cordon stations are provided in Table 2.10. The data sheets used for traffic volume surveys, O-D surveys and occupancy counts are provided in the traffic report.

The traffic volume surveys were undertaken for 24 hours in case of important screen line stations and for other screen line count stations traffic surveys were undertaken for 16 hours i.e. from 7.00 Hrs to 23.00 Hrs. The traffic volume counts were undertaken during 15th December 2007 to 20th January 2008. Only normal weekdays were considered for carrying out the traffic volume surveys. Holidays, days of the weekend and Mondays and Fridays were avoided as far as possible.

The hourly mode wise and direction wise traffic volume observed at all fourteen cordon stations and twenty screen line stations has been tabulated and presented in traffic report converting all classes of vehicle into passenger car units (PCU) produced summaries of traffic volume counts in terms of Average Daily Traffic (ADT) and Directional Design Hour Volume (DDHV). The PCU values adopted for this purpose are shown in Table 2.11. Directional design hour volume is the peak hour volume in peak direction in PCU per hour. In addition, K-factor (the proportion of daily volume occurring during peak hour) and D-factor (proportion of total peak hour volume occurring in peak direction) were also worked out. Table 2.12 gives the daily traffic volumes at all the screen line stations. The observed DDHV, K-factor and D-factor for the entire screen line count stations are shown in Table 2.13. The daily traffic volumes at the entire cordon stations are provided in Table 2.14. Table 2.15 gives the observed DDHV, K-factor and D-factor for all Outer Cordon Stations.

The observed modal shares of the traffic at outer cordon are shown in Figure 2.7, The proportion of total external traffic entering and leaving the study area through each of the cordon stations is displayed in Figure 2.8.

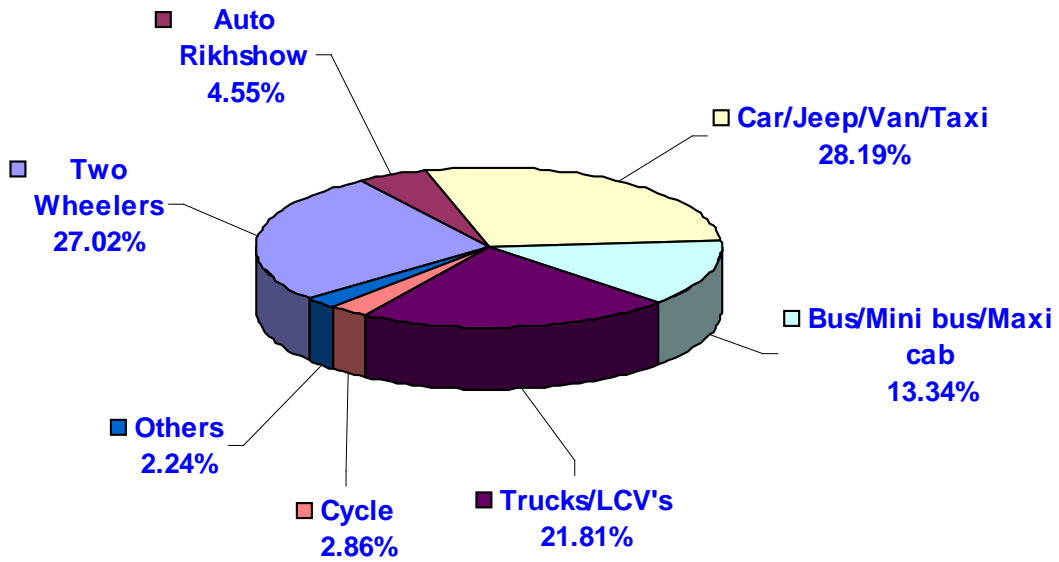


Fig 2.7 - Modal Share at Outer Cordon Stations

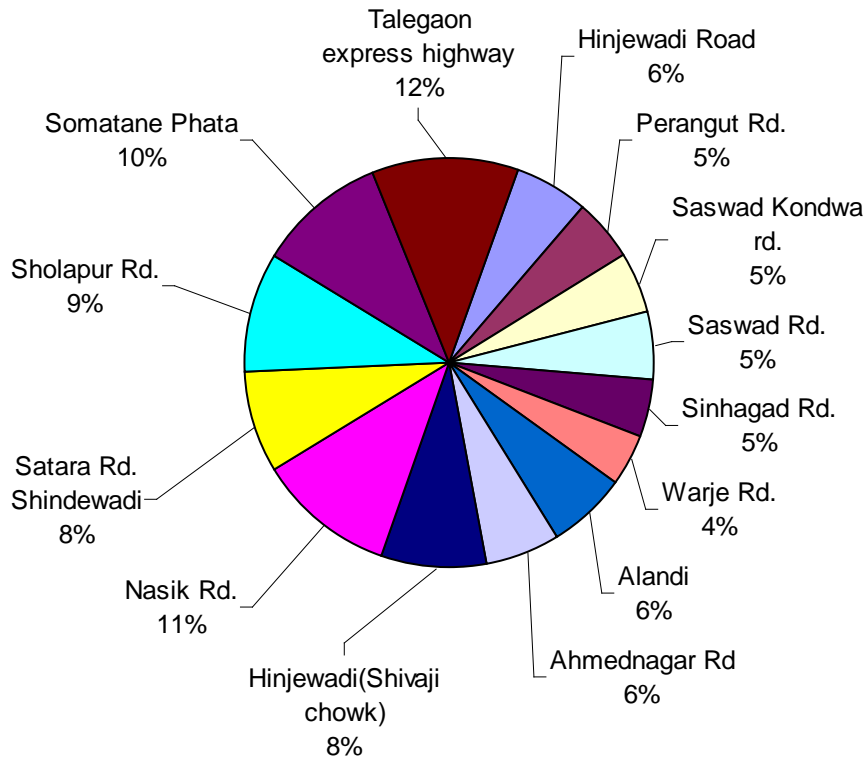


Fig 2.8 - Proportion of traffic at each Outer Cordon Station

Table 2.9- Location Details of Screen Line Stations

Station No	Name of the Station	Landmark	Duration	Occupancy Survey
1	Westerly Bye Pass	Mutha river crossing	24	Y
2	Rajaram Bridge	Sinhagad Road	16	-
3	Mathre Bridge	Anant KanKahare Path - Eradhawane Road	24	Y
4	SM Joshi Marg	LBS Road -Karve Road	16	-
5	Sambhaji Bridge	Connecting Laxmi Road and Prabhat Road	24	Y
6	Shinde Bridge	JM Road - Laxmi Road	16	-
7	Shivaji Bridge	Veer Santaji Ghorpade Road (Parallel to Dhagdi Pool)	24	Y
8	Causeway	Parallel to Shinde Bridge	16	-
9	Dhagdi Pool	Veer Santaji Ghorpade Road	16	-
10	Bund Garden Road	Bund Garden Road – Deccan College Road	24	Y
11	Wellesley Road - Nagar Road	Mula-Mutha river crossing (Yerwada IT Park)	24	-
12	Ghorpadi Mundwa Road- A Nagar Road	Mula-Mutha river crossing	16	-
13	Sangam Bridge	Mumbai Pune Road - R.B Mothilal Road	24	Y
14	Shivaji Nagar Bridge	JM Road Sangam Bridge	16	Y
15	Pimple Nilakh	Pimple Nilakh Junction	24	Y
16	Pune Mumbai Road	Between Dapodi and Kasarwadi	24	Y
17	Karve Road	Near Law College Road Junction	16	-
18	Nigdi Crossing	Chinchwad - Nigdi Road	16	Y
19	Akurdi Crossing	Chinchwad - Akurdi Road/Nigdi Road	16	-
20	Chinchwad Crossing	Chinchwad - Akurdi Road (MIDC ROAD)	24	Y

Table 2.10- Location Details of Cordon Stations

Station No	Name of the Station	Landmark	Duration	Remark
1	Talegaon	Toll Plaza, MSRDC	24 Hrs	OD and Volume Count
2	Somatane	Toll Plaza, MSRDC	24 Hrs	OD and Volume Count
3	Nasik Road	Toll Plaza, PWD	24 Hrs	OD and Volume Count
4	Alandi Road	Merging Road near NH50	16 Hrs	OD and Volume Count
5	Ahmednagar Road	Merging Road near Wagoli Road	24 Hrs	OD and Volume Count
6	Sholapur Road	Toll Plaza, NHAI	24 Hrs	OD and Volume Count
7	Saswad Road	Toll Plaza, MSRDC	16 Hrs	OD and Volume Count
8	SaswadKondwa Road	Kondwa junction	16 Hrs	Volume Count
9	Satara Road	Toll Plaza, NHAI	24 Hrs	OD and Volume Count
10	Sinhagad Road	After bridge	16 Hrs	OD and Volume Count
11	Warje Road	After bus terminal	16 Hrs	OD and Volume Count
12	Perangut Road	Near Junction	16 Hrs	OD and Volume Count
13	Hinjewadi Road	Bhumkar chowk - Hinjewadi Chowk	16 Hrs	OD and Volume Count
14	Hinjewadi Chowk	Hinjewadi Chowk	24 Hrs	OD and Volume Count

Table 2.11- PCU Values adopted for the Study

S. No	Vehicle Type	Adopted PCU Values
1	Car / Jeep	1.0
2	Bus	3.0
3	Autorickshaw	0.8
4	Two-wheeler	0.5
5	LCV/ Mini-bus	2.5
6	Truck	3.0
7	Truck Trailer	3.5

Table 2.12- Daily Traffic in PCU at Screen Line Stations

Station	Daily Traffic in PCU's		
	South Bound	North Bound	Total
Akurdi Crossing	11176	10243	21419
Causeway	14185	12751	26936
Dhagdi pool	28942	24257	53199
Ghorpadi Mundwa	20990	15250	36240
Karve road	60763	52562	113325
Nigdi Road	15790	14063	29853
Rajaram bridge	26855	19430	46285
SM Joshi bridge	10240	14103	24343
Shinde bridge	10818	15675	26492
Sancheti Bridge	18134	43497	61631
Bund garden	22752	43873	66625
Chinchwad crossing	16281	17310	33591
Mathre Bridge	22142	22635	44777
Pimple Nilakh	22628	25239	47867
Pune Mumbai	34184	47477	81662
Satara to Mumbai	28488	33476	61964
Sambhaji Bridge	26821	20956	47777
Sangam Bridge	35151	41321	76472
Shivaji bridge	12481	13752	26233
Wellesley Road	22493	19329	41822

Table 2.13- DDHV at Screen Lines Stations

Station	K-FACTOR	D-FACTOR	DDHV
Akurdi Crossing	0.08	0.68	1223
Causeway Dangre	0.09	0.56	1416
Dhagdi pool	0.08	0.68	2965
Ghorpadi Mundwa	0.08	0.62	1777
Karve road	0.07	0.55	4367
Nigdi Road	0.13	0.67	2578

Station	K-FACTOR	D-FACTOR	DDHV
Rajaram bridge	0.08	0.56	2087
SM Joshi bridge	0.08	0.7	1386
Shinde bridge	0.07	0.53	1027
Sancheti Bridge	0.07	0.68	2933
Bund garden	0.07	0.75	3748
Chinchwad crossing	0.07	0.54	1233
Mathre Bridge	0.09	0.52	2087
Pimple Nilakh	0.07	0.58	1983
Pune Mumbai	0.08	0.67	4232
Satara to Mumbai	0.08	0.6	3065
Sambhaji Bridge	0.09	0.87	3615
Wellesley Road	0.08	0.52	1674

Table 2.14- Daily Traffic in PCU at Outer Cordon Stations

Station	Daily Traffic in PCU's		
	IN	OUT	Total ADT
Hinjewadi Road	13561	11885	25446
Perangut Rd.	9377	11382	20759
Saswad Kondwa rd.	10715	9538	20253
Saswad Rd.	12743	9939	22682
Sinhagad Rd.	13566	6363	19930
Warje Rd.	9994	7939	17933
Alandi	13657	11778	25434
Ahmednagar Rd	12580	12655	25234
Hinjewadi(Shivaji chowk)	19158	16829	35987
Nasik Rd.	22959	23253	46212
Satara Rd. Shindewadi	16129	19110	35239
Sholapur Rd.	19560	20633	40193
Somatane Phata	22419	21778	44197
Talegaon express highway	25070	25469	50539

Table 2.15- DDHV in PCU at Outer Cordon Stations

Station	K- Factor	D-Factor	DDHV
Hinjewadi Road	0.08	0.62	1236
Perangut Rd.	0.07	0.63	923
SaswadKondwa rd.	0.07	0.53	710
Saswad Rd.	0.06	0.54	757
Sinhagad Rd.	0.07	0.63	897
Warje Rd.	0.06	0.6	680
Alandi	0.1	0.6	1547
Ahmednagar Rd	0.07	0.61	1142
Hinjewadi(Shivaji chowk)	0.08	0.68	2048
Nasik Rd.	0.07	0.53	1634
Satara Rd. Shindewadi	0.06	0.7	1481
Talegaon express highway	0.05	0.51	1246

2.3.4 Occupancy Counts

Occupancy counts were taken at selected screen line stations. These occupancy counts were made during morning and evening peak hours and as well as during the lean hours of the day. The average occupancy of various vehicle types for the whole day are given in Table 2.16. These values were obtained at all the 20 screen lines. These occupancy values corresponding to appropriate time of the day were used to convert vehicles to passengers and vice-versa.

Table 2.16- Average Occupancy of Vehicles

Vehicle type	Average occupancy
Two Wheeler	1.56
Autorickshaw	2.32
Maxi Cab	4.02
Taxi	3.24
Car/Jeep/Van	2.91
Mini-Bus	16.71

Vehicle type	Average occupancy
PMC/PCMC Bus	35.19
ST Bus	34.37
Other Buses	25.23

2.3.5 O-D Surveys

In order to establish the external trips entering and leaving the study area, Origin and Destination (O-D) surveys were carried out at the outer cordon stations. The O-D surveys were carried out by using the standard *Road Side Interview* method on a sample basis at the outer cordon stations. The questionnaire used for the O-D surveys is provided in traffic report. The O-D survey carried out at the outer cordon was utilized in deriving the external travel pattern for the study area. Mode wise origin-destination matrices were obtained from outer cordon data and home interview survey data. The overall magnitude of travel in the study area as obtained from these surveys is given in the end of the section 2.3.

2.3.6 Speed and Delay survey

Speed and delay survey has been carried out along the potential corridors of mass transit. The main purpose of this survey is to get the present journey times and delays along these corridors. This information has been used to adjust the parameters of the speed-flow relationships of various road links. This information has also been used to validate the public transport and highway assignment models. These journey times also gave the extent of travel time saving that one could expect on Metro.

In order to get accurate data on travel times, delays and their locations, a handheld GPS (Global Positioning System) palmtop has been used in a probe vehicle moving with the traffic. GPS receiver logs data continuously at time interval of one second. The GPS data provides both spatial and time/distance based data from which various traffic parameters can be derived, including travel time, stopped time, travel speeds (instantaneous and average), and various congestion indices. The elemental data provided by the vehicle and the GPS are stored in GIS (Geographical Information System) software running on a notebook PC in the vehicle or saved to a file. Thus the recorded data may be displayed, and analyzed using GIS-specific functionality both during the data collection and afterwards.

2.3.6.1 Corridors Selected for Speed and Delay Study

Four Major Corridors were selected for doing this survey. Each of these corridors was further subdivided in to segments in order to capture the exact peak-hour traffic conditions in the corridor. The description of these corridors and the prominent roads on the corridors is given in Table 2.18.

Table 2.17 Description of the Corridors chosen for Speed and Delay Study

Sl. No.	Corridors	Roads	Direction
1	Shivajinagar- Swargate	JM road, Tilak Road	Sancheti to Swargate
			Swargate to Sancheti
2	Shivajinagar- Nigdi	Mumbai-Pune Road	Sancheti to Nigdi Circle
			Nigdi circle to Sancheti
3	Shivajinagar- Yerwada	Bund Garden road, Nagar road	Sancheti to Wagoli
			Wagoli to Sancheti
4	Shivajinagar- Warje	JM road, Karve road	Sancheti to Karve Circle
			Karve Circle to Sancheti

2.3.6.2 Results of Speed and Delay Study

The data that was collected using the GPS palmtop during the speed and delay survey was analysed to find variation of speed along the stretches of the four corridors in northbound as well as southbound directions. The summary of journey speeds for each of the four corridors is presented in Table 2.19.

From the analysis of speed and delay data it can be observed that the journey speeds are falling below 16 km/hr over certain corridors during peak hours. From Table 2.19 It can be inferred that the journey speeds during peak hour vary between a low of 16 km/hr to a high of 26 km/hr on these four corridors. All these corridors are the main arterials of the city feeding traffic to the CBD. This indicates that the traffic flows on these streets may have to experience severe congestion with stop and go movements.

Table 2.18- Summary of Average Speeds in kmph along the Corridors

Corridors	Morning Peak		Evening Peak	
	Onward	Return	Onward	Return
Shivajinagar- Swargate	24.06	16.19	14.62	14.50
Shivajinagar- Nigdi	29.82	29.46	20.02	27.57
Shivajinagar- Yerwada	20.05	18.91	13.85	17.42
Shivajinagar- Warje	18.84	15.01	14.47	18.72

2.3.7 Home Interview Survey (HIS)

Home Interview survey among other surveys is the most important survey for any transportation study. Representative samples of dwelling units are selected and personal interviews are conducted to obtain travel characteristics for all members of the household by all modes of transportation on one full normal working day. Vast amount of information is collected on various aspects of family structure, socio-economic characteristics, location of work/study places, and information of travel attributes by all trips made on that day. This data is employed for analyzing existing travel patterns and behavior, to help in the calibration of Travel demand Models.

2.3.7.1 Types of HIS

A household interview can be administered in many different ways. Classification of techniques relate to the way a household interview is divided and the ways in which this information is sought from the interviewee.

There are various methods to capture information required from the selected households in the study area. Contact with the members of the house hold can be established by any or a combination of the methods.

- In Home personal interviews
- Telephonic interviews
- Post Card method

In the present study, personally administering a questionnaire also known as face-to-face interview, through trained enumerators was more of a necessity than a choice. Moreover, enough local experience was available in doing such surveys. All previous studies in the region as well as in other part of the country to date have relied on these time-tested methods. The format designed for the purpose consisted of three parts.

1. Survey Format Design
2. Sample Design
3. Administering the Survey

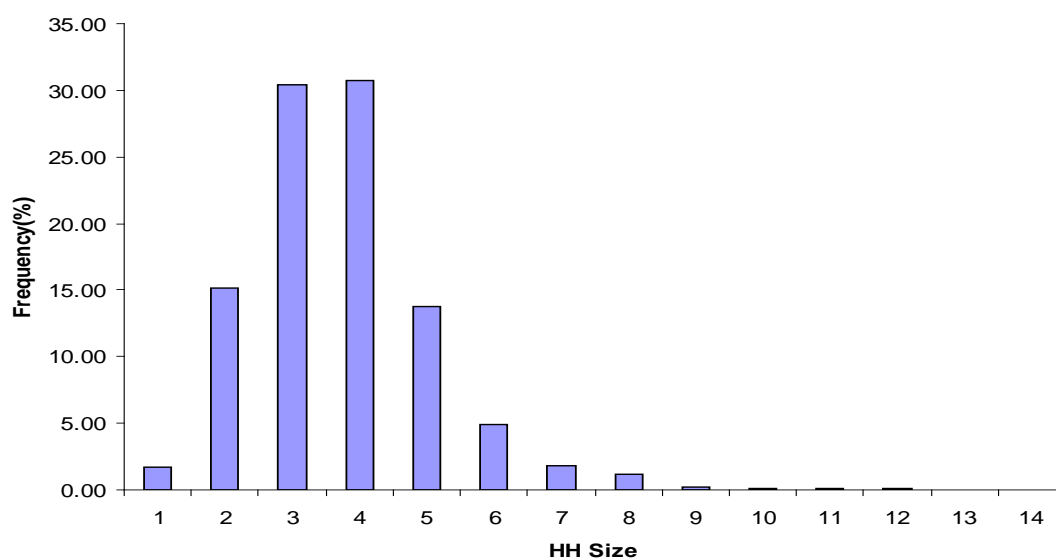
Home Interview Survey was conducted on a sample basis in 3000 households to establish the base year travel pattern. The survey included collection of information regarding the Household, Persons and Trips. A group of 50 graduate enumerators was entrusted the task of conducting the Interviews. The details of conduction of House hold survey is given in the traffic report.

2.3.7.2 Data Analysis and Results

The collected forms were transformed into soft copy by using different codes. The data was checked for rationality and legal limits during coding. The household distribution obtained from the sample was observed to be biased towards the lower household sizes. The average household size came out to be 2.7 as compared to the household size of 4.52 as per 2001 census. Bias corrections were applied to household distribution and the average household size improved to 4.31 after correction for bias. The Weightage factors used for bias correction are shown in Table 2.19. Zonal expansion factors along with these weightage factors were applied to get the expanded parameters for the whole population. The household size distribution obtained from the sample is displayed in Figure 2.9.

Table 2.19- Bias Correction Factors

HH Size	Weightage Factor
1	1.00
2	0.43
3	0.50
4	1.00
5	2.32
6	2.00
7 & above	1.00


Fig 2.9 - Household Size Distribution from HIS

Existing modal split was also evaluated from the HIS data and it was observed that the share of Public Transit was as low as 13%. Figure 2.10 shows the obtained Modal Split form HIS data.

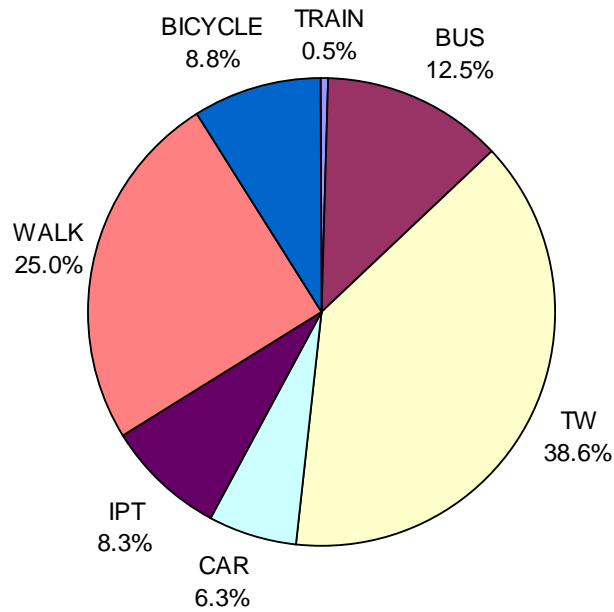


FIG2.10- MODAL SPLIT FROM HIS

It was also observed that majority of the houses were self owned and the proportion of the rented houses was very less. The ownership characteristics of the sample is displayed in Figure 2.11.

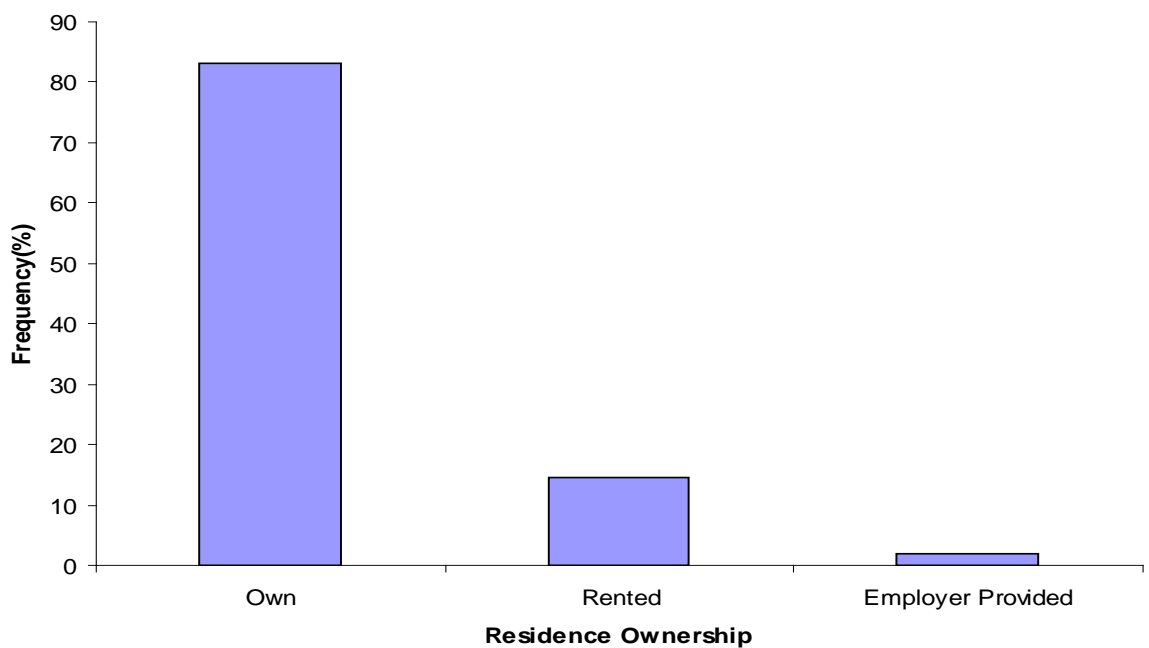


FIG 2.11- RESIDENCE OWNERSHIP

The trip length frequency considering only motorized modes is shown in Figure 2.12 and the corresponding average trip length was found to be 31 minutes. Figure 2.13 shows the Trip length frequency for all trips. The average trip length considering all modes was found to be 26 minutes.

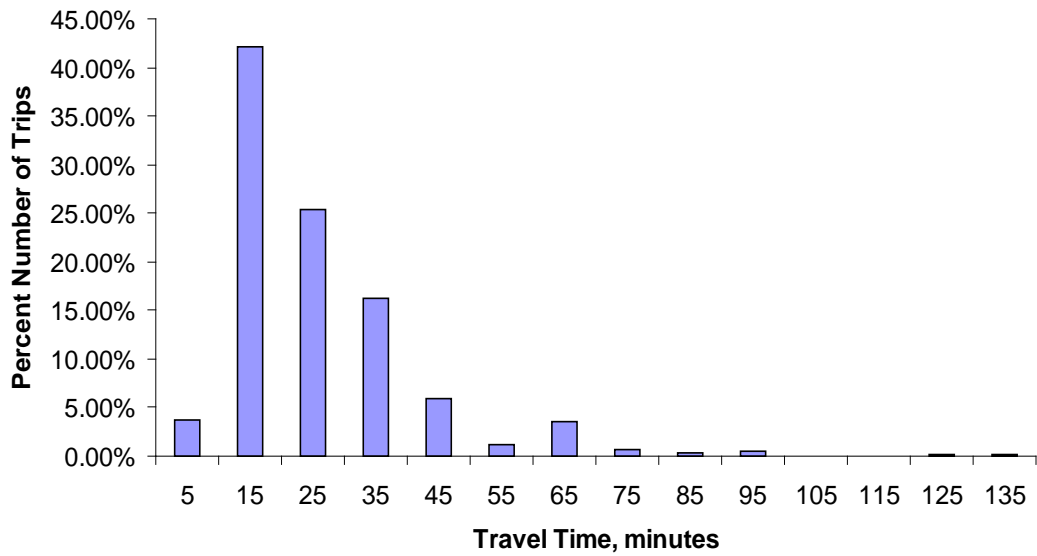


FIG2.12- TRIP LENGTH FREQUENCY DISTRIBUTION FOR MOTORIZED TRIPS FROM HIS

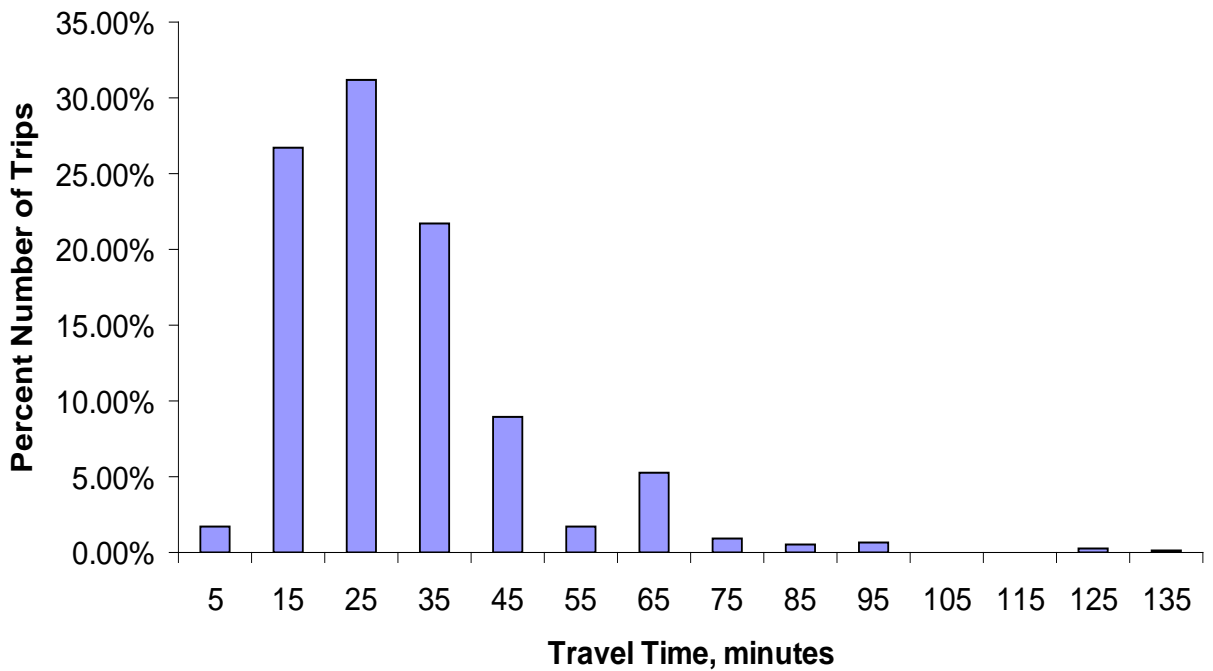


FIG 2.13- TRIP LENGTH FREQUENCY DISTRIBUTION FOR ALL TRIPS FROM HIS

From HIS data, trips made by the residents of the study area were obtained. The mode wise daily trips made by the residents of the study area are depicted in Figure 2.14

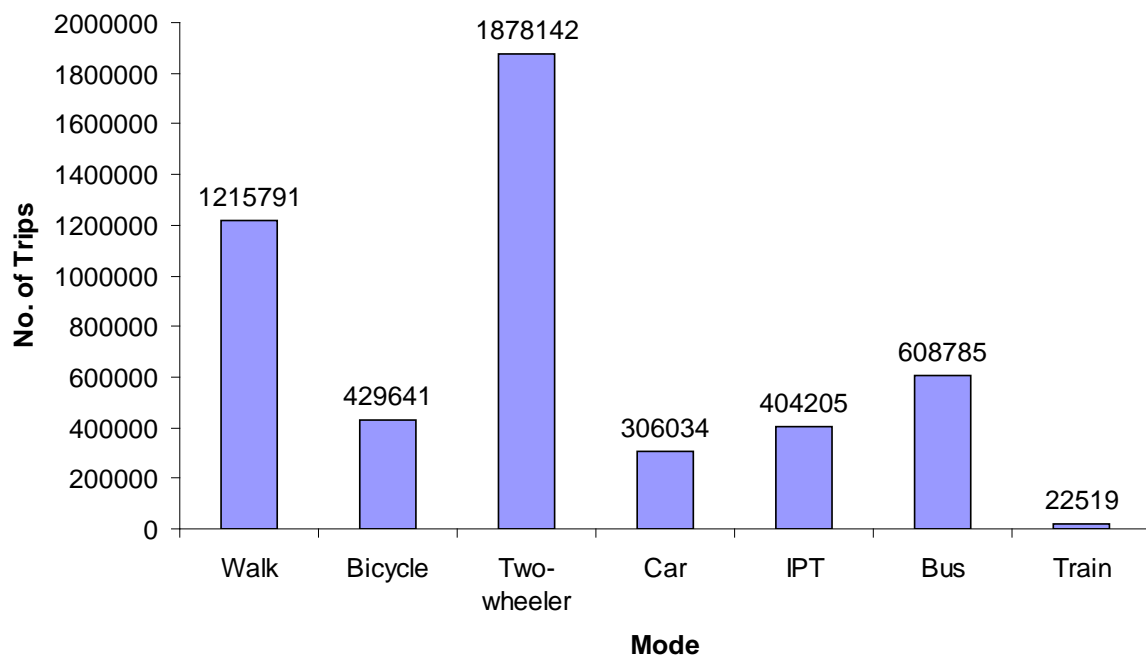


FIG 2.14- NO OF TRIPS MODE WISE FROM HIS

From OD survey and Traffic volume count at outer cordon the magnitude of external travel made by the residents as well as the non residents is obtained. The travel pattern thus obtained from both HIS and outer cordon OD surveys was collated to get the overall travel pattern of the study area. The same is reported in Table 2.20.

Table 2.20- Overall Travel pattern obtained for the Study Area

Mode	No. of Passenger Trips			
	Internal to Internal	Internal to External	External to Internal	External to External
Two Wheeler	1837861	44468	49269	11538
Car	296343	129000	125893	54851
IPT	389537	23099	20159	8379
PT	928734	278538	314849	180567
Total	3452475	475105	510170	255335
Total Trips				4693085

2.4 TRAVEL DEMAND MODEL DEVELOPMENT

2.4.1 Establishing Base Year Travel Pattern

As explained earlier, the travel pattern in the form of mode wise OD matrices were obtained following the process described in the flowchart shown in Fig. 2.6. The sources used for arriving at the base year OD pattern are the home interview survey, outer cordon OD survey, screen line traffic volume counts and occupancies. The mode wise OD matrices obtained from these primary sources were then validated by assigning them on to the respective networks and comparing the assigned and observed flows from ground counts. As the outer cordon surveys give only the external commercial vehicle trips, the internal commercial vehicle trips have been estimated from link counts using standard matrix estimation procedure.

Highway and public transport networks were coded in CUBE, a transportation planning software package. The details of the assignment procedure are discussed in the following section.

2.4.2 Highway And Public Transport Assignment

2.4.2.1 Public Transport Assignment

Peak hour public transport passenger matrix, which includes trips made by bus, Intermediate Public Transport (IPT) and train, was assigned on to the public transport network. Public transport network is prepared by coding all the bus and IPT routes on the road network. In addition, the public transport network consists of all the existing rail links with the suburban train route coded on the rail links. All the zone centroids were connected to the nearest road nodes by walk links. Road to rail node walk connections were also given appropriately.

The public transport assignment is done based on generalized time. The components of generalized time are in-vehicle travel time (IVTT), waiting time (WT), transfer penalty, fare and discomfort in time units. Accordingly, the generalized time, GT, is worked out as

$$GT = IVTT + WTFAC*WT + TRFAC*NTR + FARE / VOT + DF$$

Where,

GT	=	Generalized time in minutes
WTFAC	=	Wait time factor worked out as a ratio between value of WT and value of IVTT
TRFAC	=	Transfer penalty in minutes per transfer between modes
VOT	=	VALUE OF TRAVEL TIME, IN RS PER MINUTE
FARE	=	FARE PAID FOR JOURNEY BETWEEN ORIGIN AND DESTINATION IN RS.
DF	=	DISCOMFORT FACTOR (WORKED OUT FROM SP SURVEY)

The values of the above parameters used in public transport assignment are worked out from the choice models developed using the Stated Preference and Revealed Preference (Home Interview Survey) data obtained from primary surveys.

There are two important steps in public transport assignment, viz., path building and loading trips on to these paths. The purpose of path building is to identify all reasonable paths between zones and provide associated travel information in generalised time so that the proportion of trips using each path may be calculated at the loading stage. Between any pair of zones maximum number of trips are loaded on to the best path and other paths with longer generalized times will be loaded with fewer trips. The proportion of trips to be loaded is calculated on the basis of a logistic choice function based on generalized time.

The public transport (PT) assignment is also required to assign the trips as per the observed modal shares. In order to achieve this, the parameters of the generalised time were fixed based on the values obtained from the analysis of stated preference and revealed preference surveys. However, these values were slightly modified to get the assigned flows close to the observed ones. Several skim matrices for PT were obtained at the end of assignment which can be used for calibration of other demand models. The calibrated parameters of PT assignment Model are shown in Table 2.21

Table 2.21- Calibrated parameters of PT assignment

Parameter	Value
WTFAC	1.2
TRFAC	3
VOT	Rs 0.53/ min
DF	As per Table 6.2

Table 2.22- Crowding Table for PT Modes

Percent Standees	DF(Min)
0	3
50	5
75	20
95	45
100	300

2.4.2.2 Highway Assignment

Highway assignment has been carried out for peak hour, preloading the highway network with peak hour public transport flows. The peak hour public transport passenger trips were converted into PCUs by using appropriate PCU-passenger ratios. These peak-hour public

transport (bus and IPT) flows in terms of PCUs were preloaded on to the highway network before loading the two-wheeler and car O-D matrices. The passenger matrices of car and two-wheeler were converted into peak hour PCU units by using appropriate K factors (proportion of daily flow occurring during peak hour) and passenger-PCU conversion factors based on observed occupancies. An equilibrium procedure based on generalized cost was used in loading these car and two-wheeler matrices. The Commercial Vehicle (CV) trips were taken as preloads on highway network. The generalized cost, GC, used in highway assignment has the following form:-

$$GC = VOT * TT + TC$$

WHERE,

VOT = VALUE OF TRAVEL TIME

TT = TRAVEL TIME

TC = TRAVEL COST

Travel cost for car/two-wheeler is the perceived operating cost which was taken as the cost of fuel and oil. Two skims namely the highway time and highway travel cost were obtained from the loaded network for use with other demand models. The parameters of Generalised cost used in Highway assignment are given in Table 2.23.

Table 2.23 – Parameters of Generalised Cost Used In Highway Assignment

MODE	VOT (RS/HR)	TC (RS/ KM)
TWO WHEELER	34	1
CAR	107	5

The assignment of PT and private vehicle trips were done iteratively till an overall equilibrium was reached between PT and highway networks. After every step of this equilibrium assignment, the observed and assigned flows were compared and the matrices were adjusted if required using O-D Matrix estimation procedure.

2.4.3 Validation of Base Year Travel Pattern

The assigned total road-based flows during peak hour (in PCU) and public transport passengers in peak hour in peak direction are compared with the flows observed across the screen lines. The assigned traffic flow in terms of passenger car equivalencies across all screen lines was found to match very closely with the observed flows. In fact, the percent error between observed and assigned flows across the screen line was found to be within 0.5%. The percent error at individual screen line points, however, was found to be within 20 % at most of the screen line points. As many of the adjacent links across the screen line provide alternate crossing paths, the above error at individual links is acceptable. The public transport passenger flows assigned by the model and those observed across screen lines also match within 1% indicating that the model is capable of capturing the observed distribution

of public transport trips between bus and IPT modes. The comparison between observed and estimated trips across screen lines is shown Table 6.4. Therefore, the estimated travel pattern of the base year (2008) was found to be fairly accurate and the model performance was acceptable as established through these observations.

Table 2.24- Observed and Estimated Trips across Screen Line

	Observed	Estimated	% Error
All vehicles (PCU)	72963	72784	-0.25
PT Trips (passengers)	124855	123818	-0.83

2.4.4 Trip Generation Models

The Productions (P) and Attractions (A) of internal passenger trips by all modes for the base year (2008) were calculated from the validated P to A matrices. Trip generation models were developed using stepwise multiple linear regression technique. The calibrated trip end equations are presented below.

$$\text{Trip Productions} = 0.3498 \times \text{POP} + 0.3274 \times \text{TW} + 0.3920 \times \text{CAR}$$

(6.706) (1.983) (1.925)

$$\text{Trip Attractions} = 1.5265 \times \text{EMP} \quad (19.978)$$

where,

POP is population

TW is number of Two Wheelers

CAR is the number of Cars

EMP is Employment

Figures in the parentheses indicate the t- statistic of the parameters. R square for both the above equations was found to be 0.74 which is satisfactory.

2.4.5 Trip Distribution Model

A **Gravity Trip Distribution** model of the following form was calibrated for distributing the total internal passenger trips.

$$T_{ij} = A_i O_i B_j D_j F_{ij}$$

where,

$$A_i = \frac{1}{\sum_j B_j D_j F_{ij}}$$

F_{ij} = the deterrence function

$$= (C_{ij})^\alpha \exp(\beta C_{ij})$$

C_{ij} = Highway travel time from i to j

T_{ij} = Number of trips between zones i and j.

$$B_j = \frac{1}{\sum_i A_i O_i F_{ij}}$$

α = Calibration parameter – power function

β = Calibration parameter – exponential function

Following Gravity Model parameters for trip distribution were obtained.

$\alpha = -0.9163730$

$\beta = -0.0192746$

Figure 2.15 shows the mean and Standard Deviations of the observed and estimated values of Trip lengths. The observed and Modeled Trip length Frequency Distributions are displayed in Figure 2.16. It can be seen that the Gravity model is very closely representing the observed trip length frequency.

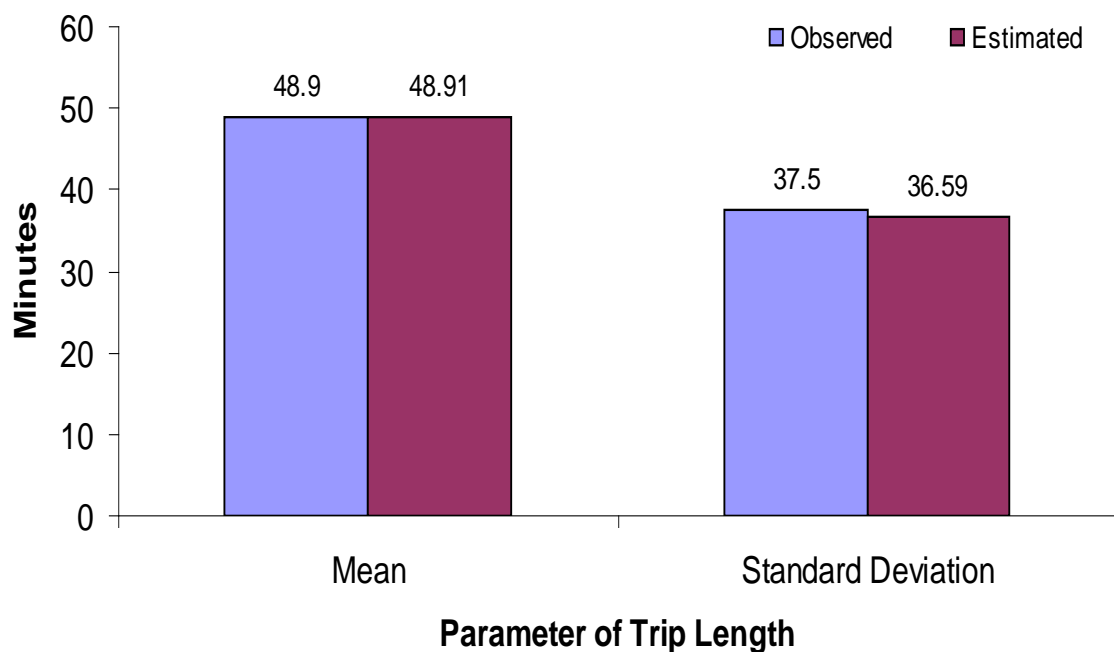


Fig2.15- Mean and Standard Deviation of the Trip length

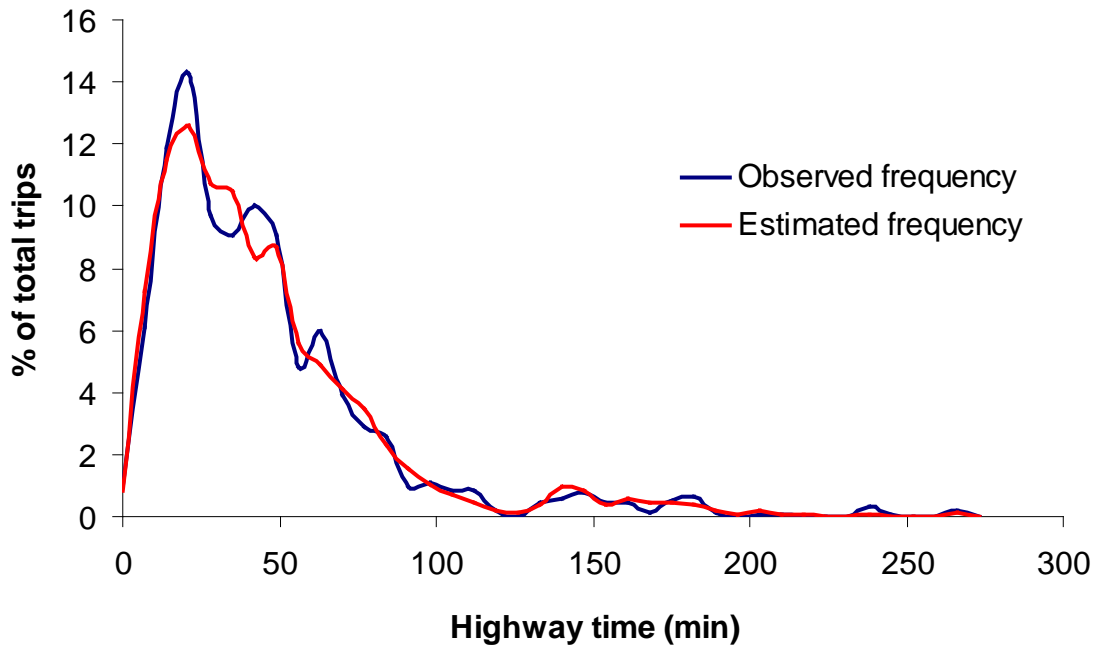


Fig 2.16- Trip Length Frequency Distributions

2.4.6 Modal Split Model

The public transport assignment model is achieving the modal split among the public-transport modes i.e., bus, rail and IPT. The input to the public transport assignment module is the total public transport person trips. The task that is remaining is to model the choice between highway and public transport modes. The following multinomial mode choice model was calibrated for this purpose.

$$P_j = \frac{e^{V_j}}{\sum_{\text{all } l} e^{V_l}}$$

WHERE,

P_j = PROBABILITY OF CHOOSING MODE J , PT, PV (TW OR CAR)

V_j = DETERMINISTIC COMPONENT OF UTILITY FOR MODE J AND

J AND L ARE INDICES FOR MODES

The utility functions of the following specifications were calibrated.

$$V_{PT} = \alpha WT_{PT} + \beta TT_{PT} + \gamma TC_{PT}$$

$$V_{PV} = \alpha WT_{PV} + \beta TT_{PV} + \gamma TC_{PV}$$

V_{PT} = deterministic component of utility of PT,
 V_{PV} = deterministic component of utility of Private vehicle,
 WT = waiting time,
 TT = travel time,
 TC = travel cost,
 α, β, γ = coefficients

The **modal split** parameters for PT and private vehicle split were estimated using the skims obtained from PT and Highway assignments. These are given below.

Wait Time coefficient, $\alpha = - 0.0046$
 Travel Time coefficient, $\beta = - 0.00614$
 Travel Cost coefficient, $\gamma = - 0.0253$
 ($\rho^2 = 0.3$)

Figure 2.17- shows the comparison between the observed and estimated Modal shares by the mode choice model.

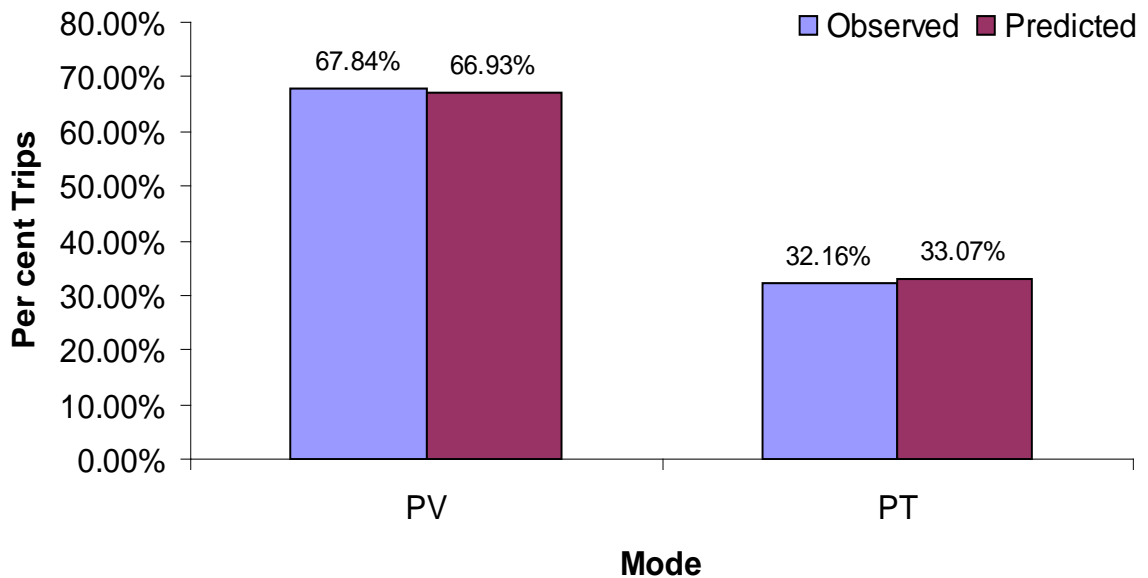


Fig.2.17- Comparison between Predicted and Observed Modal Shares

Based on the goodness of fit statistics of Trip End Models, Trip Distribution Model and Modal Split model, it can be concluded that these models will be able to project the travel pattern for future years with reasonable accuracy.

2.5 FORECASTING OF EXTERNAL TRIPS AND COMMERCIAL VEHICLE TRIPS

All the external passenger trips have been forecast using growth factor method. These growth factors were arrived at based on the growth of external traffic observed at the cordon. The commercial vehicle matrix was forecast using growth factor method. The growth factors were obtained by observing the growth rates of employment.

2.6 TRAFFIC DEMAND FORECASTING

2.6.1 Metro Corridors

The metro corridors, which form the master plan of metro lines for the study, have been adopted from RITES study discussed in section 1.2.1 of chapter 1 with some improvements to incorporate the recent dynamics in the study area. The corridors proposed by modifying the RITES study are displayed in Table 2.25.

Table 2.25- Proposed Metro Corridors

Line. No.	Details (Alignment)	Length (km)		
		Elevated	Underground	Total
1	Agricultural College to Nigdi Via Pune Mumbai Rd	16	0	16
2	Agricultural College to Warje Via JM and Karve Rd	8.7	0	8.7
3	Agricultural College to Hadapsar via Mhatre bridge	16	0	16
4	Agricultural College to Vagholi Via Bund Garden Rd	16	0	16
5	Agricultural College to Hinjewadi Via Aundh	17.5	0	17.5
6	Agricultural College to Swargate and K特拉j Via Shivaji Rd	7	5	12

Major changes have been done to line 2 and line 5. Line 2 as proposed by RITES was along the Mula River, this was changed to pass through Karve road and connect to Westerly bypass at Warje. Line 5 which was earlier proposed between Agricultural College and Chinchwad via

Aundh has now been diverted to Hinjewadi in view of the huge employment potential of Hinjewadi.

2.6.2 Parameters Of Metro Rail System

While modeling the demand for METRO, parameters of metro in terms of fares, frequencies and capacities constitute a necessary input. Fares that are considered for metro are 1.5 times that of the coded bus fare and fares used were at 2008 prices. The coded fare table has been provided in Table 2.26.

Table 2.26- Fare Table adopted for Metro

Distance (km)	Fare (Paise)
2	450
4	750
6	900
8	1050
10	1200
12	1350
14	1500
18	1800
22	2100
24	2400

2.6.3 Parameters of Other PT Modes

The parameters of existing PT modes, similar to Metro mode are also required for modeling. The suburban train running in Pune was coded at a frequency of one hour, with a seating capacity of 700 seating and 1800 crush load. Fares on suburban are significantly lower than that of bus and are coded separately. The bus fare table, route wise frequencies and capacities are obtained from PMPML. Existing BRT system was coded at a frequency of 10 minutes until 2011, and later reduced to 5 minutes. As no extra charge is being levied for BRT over the existing bus fare, fare table used for buses was also used for BRT. Capacity used for normal buses was also retained for BRT buses, as no advantage was observed in BRT buses. Six seater shared auto rickshaws plying on certain routes shared the same fare table of the bus, a frequency of 1 minute and a seating capacity of 6. Normal 3 seater auto rickshaws were also coded at 1 minute, and with a seating capacity of 3. Auto rickshaw fare has been calculated as 0.6 times distance + 2 rupees.

2.6.4 Details of Forecasts

The calibrated travel demand models, discussed have been incorporated in CUBE software to form an integrated model. For each forecasting year the model is run in an iterative manner

with complete feedback structure amongst the sub models . The overall travel estimated by the model in the above manner for the forecast years 2018, 2021, 2031 is given in Table 2.27. The model also gives the demand by individual modes for various network scenarios. The estimates of rider ship on the metro corridors are discussed in the following section.

Table 2.27- Estimated Travel for Base year and Forecast Years

Mode	2008	2011	2021	2031
PT	2143862	2224549	2979307	3509770
PV	2549053	2277876	3034045	3549735
CV (PCU)	75577	97885	119322	131806

2.6.5 Estimates of Ridership on Metro Corridors

In order to know the priority of the metro lines listed in Table 2.25, all the 6 lines were coded in the networks of all the forecast years. The forecast of ridership on all these lines for each of the forecast year has been discussed in detail in the following sub sections.

2.6.5.1 Forecast for Year 2011

The estimated peak hour loading for year 2011 is displayed in Table 2.28 and the flow diagram for the same is displayed in Fig 2.28.

Table 2.28- Peak Hour Metro Loading for the Year 2011

Line alignment	Length (km)	Passengers	Passenger-km	Lead (km)	Pass-km /km	Combined max link load	Loading (PHPPD)
1: A.C to Nigdi	16	30684	278821	9.09	17426	27121	16273
2: A.C to Warje	8.7	7489	38527	5.14	4428	6606	3964
3: A.C to Hadapsar	16	20684	134847	6.52	8428	12191	7314
4: A.C to Wagoli	16	13217	76396	5.78	4774	11740	7044
5: A.C to Hinjewadi	17.5	22278	176522	7.92	10087	18241	10944
6: A.C to Katraj	12	45684	264512	5.79	15559	36822	22093

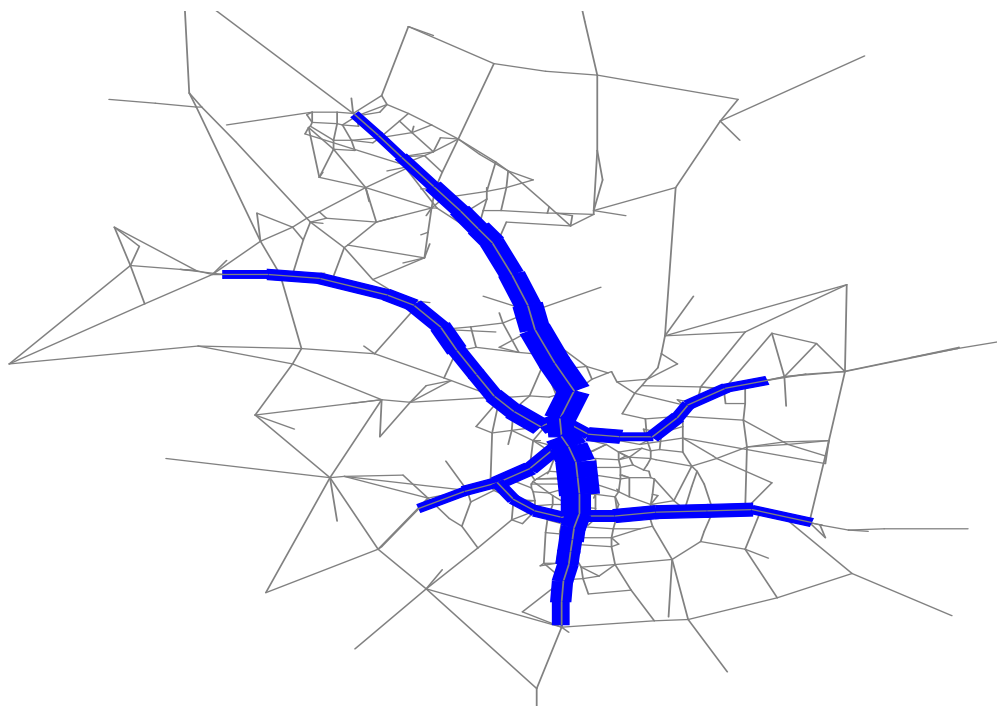


Fig 2.18- Flow Diagram for Horizon year 2011

2.6.5.2 Forecast for Year 2021

The estimated loading for horizon year 2021 is displayed in Table 2.29 and the flow diagram for the same is displayed in Fig 2.29.

Table 2.29- Peak Hour Metro Loading for the Year 2021

Line alignment	Length (km)	Passengers	Passenger -km	Lead (km)	Pass/ km	Combined max link load	Loading (PHPPD)
1: A.C to Nigdi	16	41863	368659	8.81	23041	35539	21323
2: A.C to Warje	8.7	12951	65093	5.03	7482	11176	6705
3: A.C to Hadapsar	16	29462	185251	6.29	11578	17299	10379
4: A.C to Wagoli	16	20406	115560	5.66	7222	17972	10783
5: A.C to Hinjewadi	17.5	47762	435248	9.11	24871	40403	24241
6: A.C to Katraj	12	70324	401086	5.70	23593	57739	34643

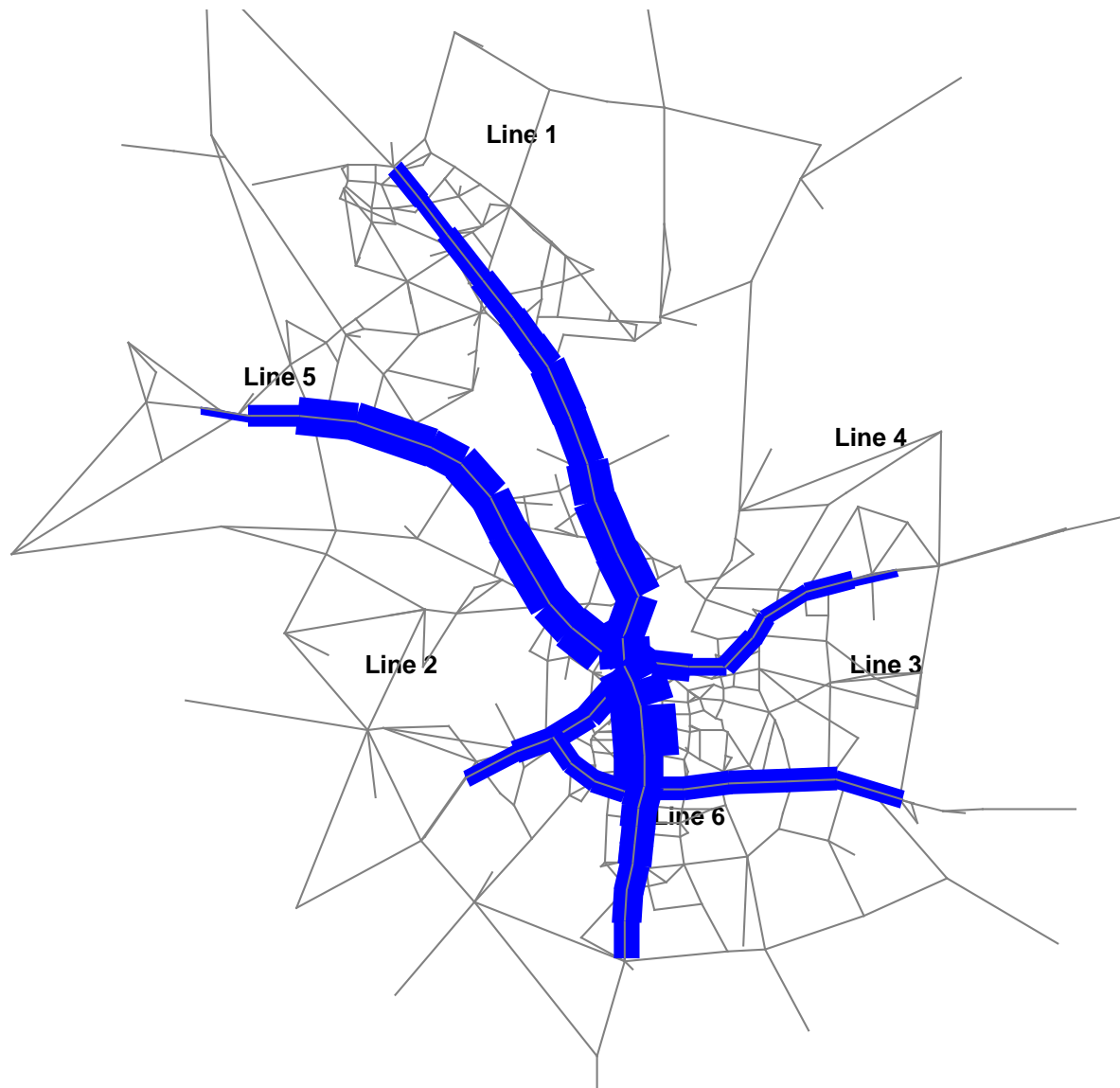


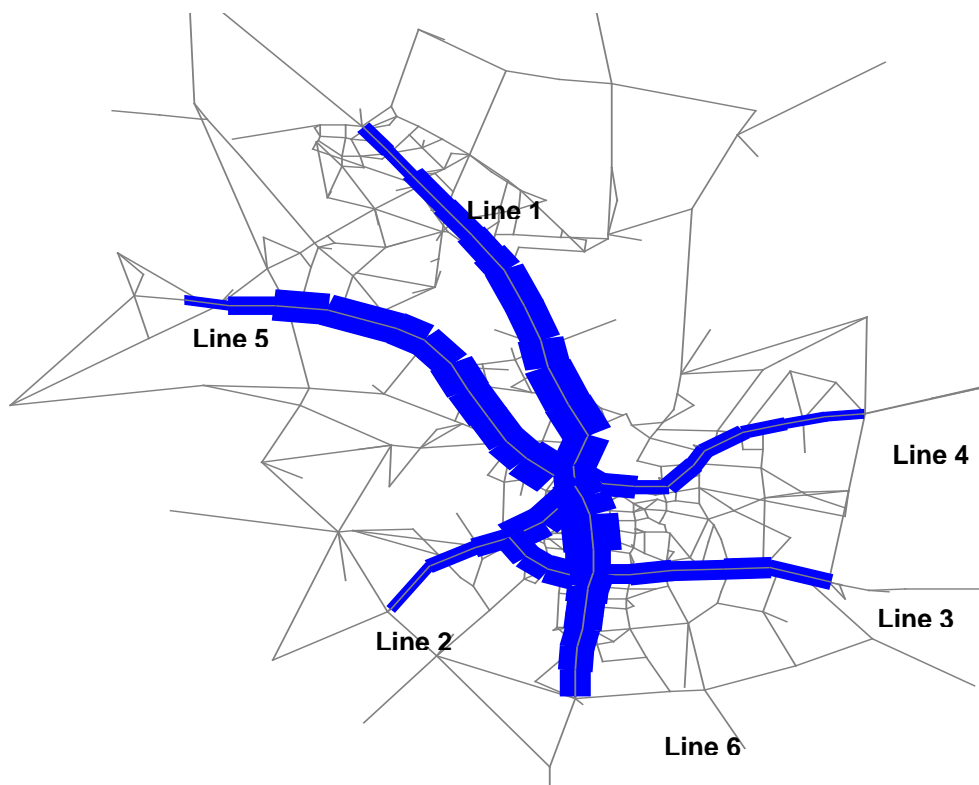
Fig 2.19- Flow Diagram for Horizon year 2021

2.6.5.3 Forecast for Year 2031

The estimated loadings for horizon year 2031 are shown in Table 2.30 and the flow diagram for the same is displayed in Fig 2.20.

Table 2.30 - Peak Hour Metro Loading for the Year 2031

Line alignment	Length (km)	Passengers	Passenger -km	Lead (km)	Pass-km /km	Combined max link load	Loading (PHPPD)
1: A.C to Nigdi	16	52671	469398	8.91	29337	44584	26750
2: A.C to Warje	8.7	21003	97443	4.64	11200	16024	9614
3: A.C to Hadapsar	16	52051	358197	6.88	22387	28260	16956
4: A.C to Wagoli	16	24073	134294	5.58	8393	21231	12738
5: A.C to Hinjewadi	17.5	58572	523380	8.94	29907	49920	29951
6: A.C to Katraj	12	79157	447757	5.66	26338	53876	32325


Fig 2.20- Flow Diagram for Horizon year 2031

2.6.6 Proposed Metro Lines and Their Phasing

Subsequently, it was felt that the corridors selected need little re-arrangement due to the fact that Hinjewadi being only under development for the time being and there are more important areas in the city which need the Metro network. Based on the estimated passenger demand and the peak hour link loads on all the links of the metro master plan network, the exact lines to be operated and their phasing was arrived at. The conclusions that emerged from the discussions of the experts from the consultants of this project, viz., DMRC and IIT Bombay and the client Pune and Pune Chinchwad Municipal Corporation were also incorporated while arriving at the exact lines and their phasing. These discussions were based on the results of rider ship estimation and practicality of implementation.

Therefore the under mentioned corridors were selected and rider ship projections made. These corridors are shown in Fig. 2.21

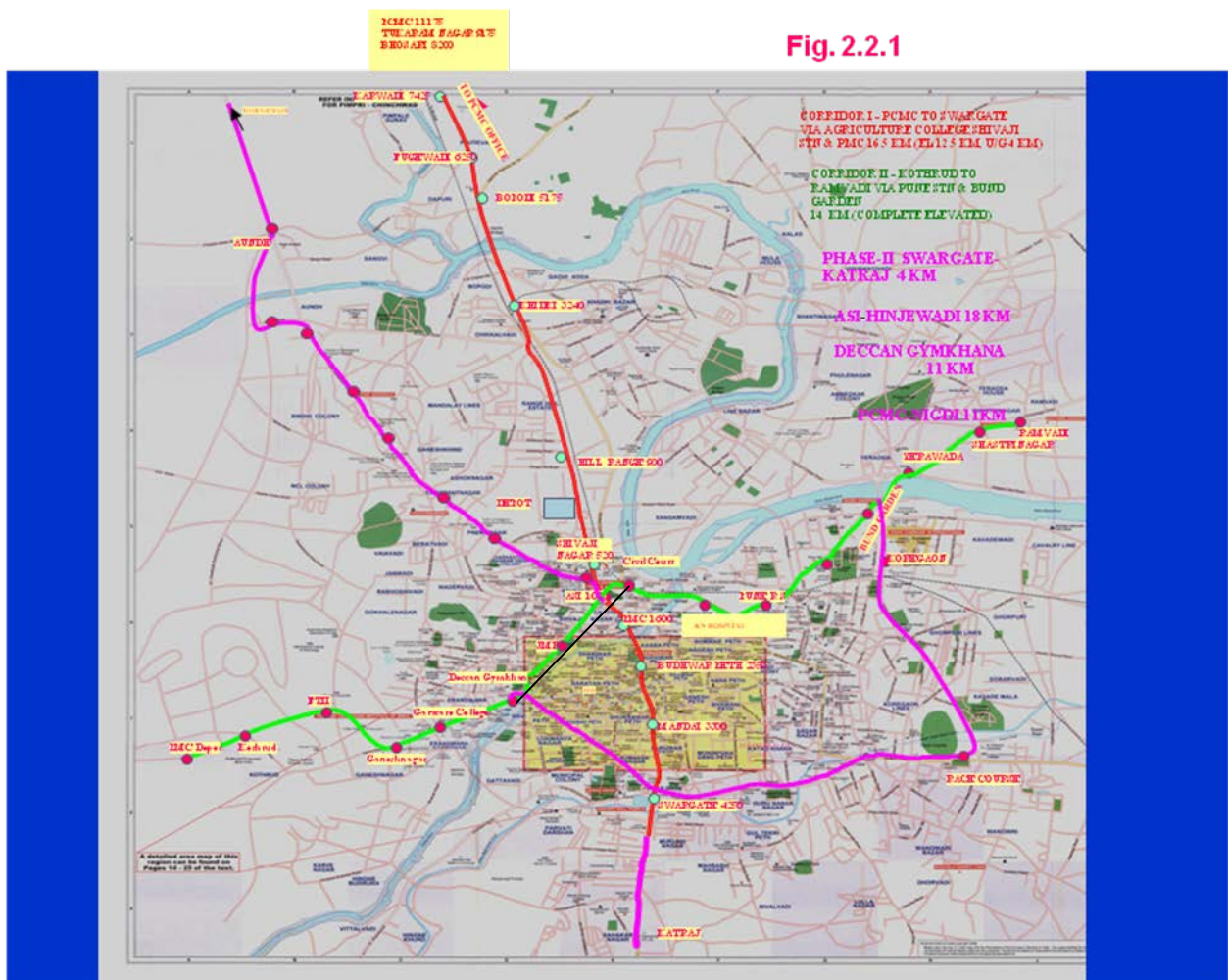


Fig 2.21 – Corridors Selected

- **Metro Line 1:** This line is from Nigdi to Katraj and runs via Pimpri Chinchwad, Agricultural College and Swargate. Line 1 and Line 6 of the master plan network were combined into a single line to form this Metro Line 1.
- **Metro Line 2:** This line is from Kothrud to Ramvadi and runs via Nal Point, ASI, Civil Court, Pune Station and Bund Garden. Line 4 and Line 2 of the master plan network were combined into a single line to form this Metro Line 2.
- **Metro Line 3:** This line is from Deccan Gymkhana to Bund Garden via Swargate, Hadapsar Road, Golf Course and

The metro master network that was studied earlier has been revised and given in Table 2.31. These lines have been coded with an average station spacing of 1 to 1.2 m and with appropriate access links. A detailed estimate of the passenger demand only for Phase- I is given in the subsequent paras.

Table 2.31- Recommended Metro Lines and Their Phasing

Line Designation	Phasing	Details of the Phase	Length, km (Approx.)
Metro Line 1	Phase-I (2013)	Pimpri Chinchwad to Swargate via Agricultural College ShivajiNagar,PMC	16.59
	Phase-II (2021)	Extension from Chinchwad to Nigdi and Swargate to Katraj	15
Metro Line 2	Phase-I (2013)	Vanaz to Ramavadi via Nal Point, Civil Court and Pune Station	14.665
Metro Line 3	Phase- I (2021)	Deccan Gymkhana to Bund Garden via Swargate , Hadapsar Road, Golf Course and Koregaon	11
Metro Line 4	Phase-II (2021)	ASI to Hinjewadi via University and Aundh	18
Total			75.5

2.7 DETAILED ESTIMATION OF RIDERSHIP ON THE RECOMMENDED METRO SYSTEM

Rider ship assessment only for Phase I have been done for the two Scenarios namely; i) Optimistic projections and ii) most likely projections.

The detailed estimation of rider ship for the recommended under mentioned metro network for both the above scenarios is given in the subsequent paras.

Corridor 1: Pimpri Chinchwad (PCMC) to Swargate via Shivaji Nagar, Pune Municipal Corporation having length of 16.59 km with 9 elevated stations & 6 underground Stations.

Corridor 2: Vanaz (Kothrud Depot) to Ramvadi via Pune Railway Station, Bund Garden having length of 14.665 km with 16 stations all elevated.

2.7.1 Optimistic Projections

The estimated peak hour section load and station wise boarding and alighting for corridors 1, 2 are given in the subsequent paragraphs.

2.7.1.1 SECTIONAL LOADS (PEAK HOUR)

TABLE 2.32 -SECTIONAL LOAD FOR CORRIDOR-I

From station	To station	2018		2021		2031	
		Forward	Reverse	Forward	Reverse	Forward	Reverse
PCMC	Tukaram Nagar	11855	11185	12114	11576	10246	12904
Tukaram Nagar	Bhosari	14342	14097	14604	14391	12712	15724
Bhosari (Nashik Phata)	Kasarwadi	15577	14557	16040	14526	16527	15918
Kasarwadi	Fugewadi	15515	15857	15997	15576	16799	17917
Fugewadi	Dapodi	15784	16325	16288	16098	17177	19144
Dapodi	Bopodi	17375	18075	18000	18051	18909	21283
Bopodi	Khadki	18892	19488	19699	19693	20592	22840
Khadki	Range Hill	18409	18760	19131	19075	20206	22026
Range Hill	Shivaji Nagar	18232	18489	18821	18888	19375	20915
Shivaji Nagar	A S I	16616	16864	17030	17227	17971	19138
A S I	Pune Municipal Corporation	16413	14653	16166	14717	17874	15461
Pune Municipal Corporation	BudhwarPeth	18221	17196	17625	16685	23387	16550
BudhwarPeth	Mandai	17612	17528	16967	16819	23021	15625
Mandai	Swargate	10044	17358	9651	16719	12686	15587

TABLE 2.33 -SECTIONAL LOAD FOR CORRIDOR-II

From station	To station	2018		2021		2031	
		Forward	Reverse	Forward	Reverse	Forward	Reverse
Vanaz	Anand Nagar	6716	4017	7514	4527	8427	7152
Anand Nagar	Ideal Colony	7281	4330	8125	4907	9255	7858
Ideal Colony	Nal Stop	7299	4423	8141	5011	9288	7958
Nal Stop	Garware College	12728	11068	14346	12853	18651	17272
Garware College	Deccan	13944	12164	15681	13947	19855	19541
Deccan	A S I	15760	14271	18244	16584	22414	19693
A S I	Civil Court	14205	12656	16557	14545	19507	16621
Civil Court	MangalwarPeth	9357	9296	10806	10152	12891	12424
MangalwarPeth	Pune Railway Station	11639	12629	13012	13735	15688	15718
Pune Railway Station	Ruby Clinic	8772	9584	9727	10317	11758	12169
Ruby Clinic	Bund Garden	8214	8714	8935	9329	10776	11292
Bund Garden	Yerawada	7140	6964	7777	7417	9162	9022
Yerawada	Kalyani Nagar	5720	5638	6176	6046	7140	7020
Kalyani Nagar	Ramvadi	1855	1805	2023	1943	2267	2303

2.7.1.2 STATION LOADS (PEAK HOUR)
TABLE 2.34 -STATION LOAD FOR CORRIDOR-I

S. No	Station Name	2018		2021		2031	
		Boarding	Alighting	Boarding	Alighting	Boarding	Alighting
1	PCMC	11855	11185	12114	11576	10246	12904
2	Tukaram Nagar	2494	2921	2498	2824	2481	2834
3	Bhosari (Nashik Phata)	1237	462	1438	137	4219	597
4	Kasarwadi	3003	4364	3601	4693	4870	6597
5	Fugewadi	269	468	291	521	378	1227
6	Dapodi	3363	3522	3572	3814	3900	4307
7	Bopodi	2559	2455	2715	2658	3067	2941
8	Khadki	738	493	631	581	864	436
9	RangeHill	3761	3667	3564	3688	4273	3993
10	Shivaji Nagar	1630	1620	1665	1794	1783	1409
11	A S I	10758	8751	11521	9876	16841	13261

S. No	Station Name	2018		2021		2031	
		Boarding	Alighting	Boarding	Alighting	Boarding	Alighting
12	P M C	6110	6845	6947	7456	8766	4343
13	BudhwarPeth	1453	2394	1341	2133	2024	1465
14	Mandai	603	8000	578	7793	450	10747
15	Swargate	17358	10044	16719	9651	15587	12686
	Total	67190	67190	69195	69195	79748	79748

TABLE 2.35 - STATION LOAD FOR CORRIDOR-II

S. No	Station Name	2018		2021		2031	
		Boarding	Alighting	Boarding	Alighting	Boarding	Alighting
1	Vanaz	6716	4017	7514	4527	8427	7152
2	Anand Nagar	565	313	611	381	828	705
3	Ideal Colony	18	93	16	104	33	101
4	Nal Stop	7128	8343	8257	9893	10726	10678
5	Garware College	1638	1518	1778	1537	1838	2902
6	Deccan	8920	9213	10388	10463	14515	12107
7	A S I	2115	2054	2591	2239	3796	3632
8	Civil Court	7267	8756	8674	10033	9484	11902
9	MangalwarPeth	3730	4782	4026	5404	5732	6230
10	Pune Railway Station	5250	5072	5884	5751	7149	7530
11	Ruby Clinic	1531	1217	1714	1517	1700	1805
12	Bund Garden	2279	1602	2491	1736	2947	2291
13	Yerawada	1944	2038	2059	2290	2782	2801
14	Kalyani Nagar	3844	3875	4117	4166	4723	4880
15	Ramwadi	1805	1855	1943	2023	2303	2267
	Total	54748	54748	62063	62064	76983	76983

2.7.1.3 Summary of Passenger Loading (Peak Hour) - Corridor-I
Table 2.36 -Coridor-I: PimpriChinchwad (PCMC) – Swargate Section

Year	2018	2021	2031
Boarding	67190	69195	79748
Passenger km	604711	553560	558236
Average Lead	9	8	7

2.7.1.4 Summary of Passenger Loading (Peak Hour) -Corridor-II

Table 2.37 -Corridor-II:Vanaz – Ramvadi Section

Year	2018	2021	2031
Boarding	54747.5	62063	76983
Passenger km	273737.5	310315	384915
Average Lead	5	5	5

2.7.1.5 Daily Ridership, Passenger km and Average Lead
Table 2.38 –Pimpri Chinchwad(PCMC): Swargate Section-Corridor-I

Year	2011	2018	2021	2031
Daily Ridership	480860	516855	532281	613442
Passenger km	2787096	4651692	4258248	4294094
Average Lead	9	9	8	7

Table 2.39 -Vanaz – Ramvadi Section-Corridor-II

Year	2011	2018	2021	2031
Daily Ridership	289813	421123	477399	592168
Passenger km	2787096	2105616	2386995	2960840
Average Lead	5	5	5	5

2.7.2 Most likely Traffic Projections
2.7.2.1 SECTIONAL LOADS (PEAK HOUR)
TABLE 2.40 -CORRIDOR I: SECTIONAL LOAD (PEAK HOUR)

From station	To station	2018		2021		2031	
		Forward	Reverse	Forward	Reverse	Forward	Reverse
PCMC	Tukaram Nagar	6339	5631	9744	9004	11309	10580
Tukaram Nagar	Bhosari (Nashik Phata)	8711	8480	12598	12117	13716	13431
Bhosari (Nashik Phata)	Kasarwadi	9829	9555	14334	13281	15691	14470
Kasarwadi	Fugewadi	11097	11036	15460	15158	16937	16580
Fugewadi	Dapodi	11378	11297	15692	15500	17195	16985
Dapodi	Bopodi	13147	13146	17318	17357	18521	18346
Bopodi	Khadki	14509	14481	18961	18860	20035	19376

From station	To station	2018		2021		2031	
		Forward	Reverse	Forward	Reverse	Forward	Reverse
Khadki	RangeHill	14231	14171	18344	18058	18928	17626
Range Hill	Shivaji Nagar	14465	14085	18091	17709	18508	17779
Shivaji Nagar	A S I	13367	12947	16596	16295	16667	15845
A S I	Pune Municipal Corporation	14756	13346	14873	14403	15803	14924
Pune Municipal Corporation	BudhwarPeth	17824	17557	17688	16918	18704	18551
BudhwarPeth	Mandai	17247	17905	17096	16676	17468	18653
Mandai	fugewadi	9030	17586	8563	16487	8608	18505

TABLE 2.41- CORRIDOR II- SECTIONAL LOAD (PEAK HOUR)

From station	To station	2018		2021		2031	
		Forward	Reverse	Forward	Reverse	Forward	Reverse
Vanaz	Anand Nagar	2168	2094	4134	2849	5833	3431
Anand Nagar	Ideal Colony	2469	2241	4371	3087	6289	3748
Ideal Colony	Nal Stop	2493	2252	4392	3137	6294	3805
Nal Stop	Garware College	4400	4654	6365	7254	9838	9872
Garware College*	Deccan	5175	5966	7112	7883	10479	10591
Deccan*	A S I	4678	5753	7110	7194	10982	10880
A S I*	Civil Court	4098	5054	6431	5813	10226	8685
Civil Court*	Mangalwar Peth	3577	4605	5339	6152	7477	7990
Mangalwar Peth	Pune Railway Station	5419	6203	7582	8519	9868	10320
Pune Railway Station	Ruby Clinic	4737	5265	6149	7106	7634	8227
Ruby Clinic	Bund Garden	4753	5044	6172	6691	7258	7692
Bund Garden	Yerawada	4075	4086	5279	5405	6278	6129
Yerawada	Kalyani Nagar	3417	3443	4341	4394	5032	4938
Kalyani Nagar	Ramwadi	1050	1100	1358	1381	1661	1595

*Between Garware college & City civil court 3 stations proposed (Deccan, Sambhaji park & PMC)

2.7.2.2 STATION LOADS (PEAK HOUR)
TABLE 2.42-CORRIDOR I- STATION LOAD

S. No	Station Name	2018		2021		2031	
		Boarding	Alighting	Boarding	Alighting	Boarding	Alighting
1	PCMC	8552	7824	9744	9004	11309	10580
2	Tukaram Nagar	2690	3025	2859	3118	2413	2858
3	Bhosari (Nashik Phata)	1520	1133	1736	1164	1975	1039
4	Kasarwadi	1601	2164	1589	2341	1747	2611
5	fugewadi	249	313	231	341	258	404
6	Dapodi	3047	3224	3249	3479	3471	3506
7	Bopodi	2442	2343	2674	2535	2879	2395
8	Khadki	637	505	812	626	1751	1109
9	Range Hill	3663	3489	3851	3755	3884	4457
10	Shivaji Nagar	1324	1362	1421	1501	1937	1844
11	A S I	7861	7406	7773	7605	10316	10259
12	P M C	4217	4422	4210	3910	4232	4958
13	Budhwar Peth	2186	2737	2432	2782	1301	2638
14	Mandai	526	8714	515	8860	598	9310
15	Swargate	16872	8727	16487	8563	18505	8608
	Total	57386	57387	59584	59584	66576	66576

TABLE 2.43-CORRIDOR II- STATION LOAD

S. No	Station Name	2018		2021		2031	
		Boarding	Alighting	Boarding	Alighting	Boarding	Alighting
1	Vanaz	3446	2585	4134	2849	5833	3431
2	Anand Nagar	260	207	237	238	456	317
3	Ideal Colony	22	37	21	50	5	57
4	Nal Stop	3008	4574	3472	5616	5423	7946
5	Garware College*	996	1107	1046	928	1179	1257
6	Deccan*	3905	3557	4554	3867	6084	5871
7	A S I*	1479	980	1765	1062	2681	1242
8	Civil Court*	2309	3263	2241	3671	4543	6597
9	Mangalwar Peth	2232	2229	2388	2514	3022	2960
10	Pune Railway Station	3084	3007	3488	3508	4480	4621
11	Ruby Clinic	785	417	924	486	1099	940
12	Bund Garden	1513	1160	1675	1282	2078	1495

S. No	Station Name	2018		2021		2031	
		Boarding	Alighting	Boarding	Alighting	Boarding	Alighting
13	Yerawada	1293	1249	1460	1386	1752	1807
14	Kalyani Nagar	2784	2773	3017	2987	3347	3375
15	Ramwadi	1283	1250	1381	1358	1595	1661
	Total	28396	28396	31803	31803	43577	43577

*Between Garware college & City civil court 3 stations proposed (Deccan, Sambhaji park & PMC)

2.7.2.3 Summary of Passenger Loading (Peak Hour)

TABLE 2.44 -CORRIDOR-I - PIMPRI CHINCHWAD (PCMC) – SWARGATE SECTION

Year	2018	2021	2031
Boarding	57386	59584	66576
Passenger km	516478	476672	466032
Average Lead	9	8	7

2.7.2.4 Summary of Passenger Loading (Peak Hour)

Table 2.45 - Corridor-II Vanaz – Ramvadi Section

Year	2018	2021	2031
Boarding	28396	31803	43577
Passenger km	141980	159015	217885
Average Lead	5	5	5

2.8 Based on the experience of Delhi Metro the optimistic projections are normally not achieved and it is felt that initially the most likely rider ship may only materialize. Hence, the all further planning for the Metro infrastructure is done for catering the most likely projections. The daily sectional loads and Station loads for this Scenario are given as under.

2.8.1 Most Likely Sectional Loads (Daily)

TABLE 2.46 -CORRIDOR -I

From station	To station	2018		2021		2031	
		Forward	Reverse	Forward	Reverse	Forward	Reverse
PCMC	Tukaram Nagar	85326	85326	83500	83500	90376	90376
Tukaram Nagar	Bhosari (Nashik Phata)	114185	114185	112575	112575	120403	120403
Bhosari	Kasarwadi	116255	116255	115351	115351	124183	124183

From station	To station	2018		2021		2031	
		Forward	Reverse	Forward	Reverse	Forward	Reverse
(Nashik Phata)							
Kasarwadi	Fugewadi	96218	96218	97588	97588	102423	102423
Fugewadi	Dopodi	101962	101962	109636	109636	108372	108372
Dapodi	Bopodi	110874	110874	119331	119331	120957	120957
Bopodi	Khadki	112006	112006	121339	121339	121848	121848
Khadki	Range Hill	115770	115770	126073	126073	131369	131369
Range Hill	Shivaji Nagar	105805	105805	115584	115584	122888	122888
Shivaji Nagar	A S I	94035	94035	103970	103970	113931	113931
A S I	Pune Municipal Corporation	92162	92162	102062	102062	111723	111723
Pune Municipal Corporation	Budhwar Pet	82448	82448	92050	92050	100535	100535
Budhwar Peth	Mandai	73607	73607	82384	82384	90489	90489
Mandai	Swargate	54584	54584	62492	62492	72965	72965

TABLE 2.47 - CORRIDOR -II

From station	To station	2018		2021		2031	
		Forward	Reverse	Forward	Reverse	Forward	Reverse
Vanaz	Anand Nagar	20102	20102	23277	23277	30880	30880
Anand Nagar	Ideal Colony	21656	21656	24862	24862	33457	33457
Ideal Colony	Nal Stop	21849	21849	25097	25097	33664	33664
Nal Stop	Garware College	40073	40073	45398	45398	65702	65702
Garware College*	Deccan	45485	45485	49981	49981	70233	70233
Deccan*	A S I	43163	43163	47681	47681	72876	72876
A S I*	Civil Court	37206	37206	40813	40813	63037	63037
Civil Court*	Mangalwar Peth	34441	34441	38302	38302	51557	51557
Mangalwar Peth	Pune Railway Station	48442	48442	53667	53667	67295	67295
Pune Railway Station	Ruby Clinic	40390	40390	44185	44185	52869	52869
Ruby Clinic	Bund Garden	39302	39302	42879	42879	49835	49835
Bund Garden	Yerawada	32670	32670	35615	35615	41356	41356
Yerawada	Kalyani Nagar	26929	26929	29117	29117	5032	4938
Kalyani Nagar	Ramwadi	8445	8445	9133	9133	1661	1595

*Between Garware college & City civil court 3 stations proposed (Deccan, Sambhaji park & PMC)

Most Likely Station Loads (Daily)
TABLE 2.48 –CORRIDOR- I

S.No	Station Name	2018		2021		2031	
		Boarding	Alighting	Boarding	Alighting	Boarding	Alighting
1	PCMC	85326	85326	83500	83500	11309	10580
2	Tukaram Nagar	30801	30801	31252	31252	2413	2858
3	Bhosari (Nashik Phata)	16411	16411	17382	17382	1975	1039
4	Kasarwadi	28797	28797	27067	27067	1747	2611
5	Fugewadi	50891	50891	51261	51261	258	404
6	Dapodi	8954	8954	9738	9738	3471	3506
7	Bopodi	23840	23840	25351	25351	2879	2395
8	Khadki	3808	3808	4793	4793	1751	1109
9	RangeHill	15949	15949	17363	17363	3884	4457
10	Shivaji Nagar	20901	20901	22428	22428	1937	1844
11	A S I	1873	1873	1908	1908	10316	10259
12	P M C	12549	12549	13100	13100	4232	4958
13	Budhwar Peth	8843	8843	9668	9668	1301	2638
14	Mandai	19051	19051	19925	19925	598	9310
15	Swargate	54585	54585	62493	62493	18505	8608
	Total	382577	382577	397229	397229	443849	443849

TABLE 2.49 -CORRIDOR -II

S. No.	Station Name	2018		2021		2031	
		Boarding	Alighting	Boarding	Alighting	Boarding	Alighting
1	Vanaz	20102	20102	23277	23277	30880	30880
2	Anand Nagar	1554	1554	1585	1585	2577	2577
3	Ideal Colony	194	194	235	235	207	207
4	Nal Stop	25272	25272	30292	30292	44563	44563
5	Garware College	7010	7010	6578	6578	8121	8121
6	Deccan	24877	24877	28073	28073	39850	39850
7	A S I	8198	8198	9424	9424	13077	13077
8	Civil Court	18571	18571	19707	19707	37131	37131
9	Mangalwar Peth	14870	14870	16340	16340	19940	19940
10	Pune Railway Station	20303	20303	23320	23320	30336	30336
11	Ruby Clinic	4005	4005	4699	4699	6800	6800
12	Bund Garden	8912	8912	9857	9857	11909	11909
13	Yerawada	8472	8472	9486	9486	11863	11863
14	Kalyani Nagar	18523	18523	20013	20013	22407	22407
15	Ramwadi	8445	8445	9133	9133	10854	10854

S. No.	Station Name	2018		2021		2031	
		Boarding	Alighting	Boarding	Alighting	Boarding	Alighting
	Total	189306	189306	212019	212019	290515	290515

*Between Garware college & City civil court 3 stations proposed (Deccan, Sambhaji park & PMC)

2.8.3 Daily Ridership, Passenger km and Average Lead

Table 2.50 –Pimpri Chinchwad(PCMC) – Swargate Section

Year	2018	2021	2031
Daily Ridership	382577	397229	443849
Passenger km	3443190	3177832	3106943
Average Lead	9	8	7

Table 2.51 -Vanaz – Ramvadi Section

Year	2018	2021	2031
Daily Ridership	189306	212019	290515
Passenger km	946532	1060095	1452575
Average Lead	5	5	5



Fig 2.22

Chapter - 3

Need for a Metro System



- 3.0 Why a Metro?
- 3.1 Types of Metros and Their Capacity
- 3.2 Advantages of a Metro System



CHAPTER - 3

NEED FOR METRO SYSTEM

3.1 WHY A METRO?

Public Transport System is an efficient user of space and energy, with reduced level of air and noise pollution. As the population of a city grows, share of public transport, road or rail-based, should increase. For a city with population of 1.0 million, the share of public transport should be about 40% - 45%. The percentage share of public transport should progressively increase with further growth in the city population, reaching a value of about 75% when the population of the city touches 5 million mark.

Whether public transport system on a corridor in the city should be road-based or rail-based will depend primarily on the traffic density during peak hours on the corridor. Experience has shown that in mixed traffic conditions, comprising slow and fast moving traffic prevailing in most of our cities, road buses can optimally carry 8,000 persons per hour per direction (phpdt). When traffic density on a corridor exceeds 8,000 phpdt, average speed of buses comes down, journey time increases, air pollution goes up, and commuters are put to increased level of inconvenience. Thus when on a corridor, traffic density during peak hours crosses this figure, provision of rail-based mass transport, i.e. Metro system should be considered. In any case, Metro system may become inescapable if the traffic density on a corridor reaches 15,000 phpdt.

Pune is one of the largest cities of Maharashtra State. Pune has grown manifold over the last two decades in terms of area, population and habitation. The city limits have increased a lot and areas like Aundh, Kothrud stand as one of the fastest growing suburbs. In Pune District, there are two Municipal Corporations viz., Pune Municipal Corporation (PMC) and Pimpri Chinchwad Municipal Corporation (PCMC) and the district is spread over an area of 15642 sq.km.

In the last census (2001), the population of the district was 72.33 lakhs out of which the urban population of Pune city was estimated as 58.08%. Population projections suggest that in 2021, there might be 68.97 lakhs people in Pune and the population size of the city may cross 77 lakhs by 2031.

With growing population and industrial and commercial development plans coming up for the City, the travel demand is expected to grow steeply. With the growing economy and inadequate public transport services, the passengers shall shift to private modes, which is already evident from the high vehicle ownership trends in the region. This would not only aggravate the congestion on streets but also increase the pollution. Hence, it is essential to plan and provide for a Metro System in Pune Metropolitan area.

A study carried out by Delhi Metro Rail Corporation has shown that the break-even point between bus transport and rail-based metro system is 8,000 phpdt considering only Operation and Maintenance (O&M) cost and depreciation. If, however, along with O&M cost and depreciation the cost of capital at 10% interest rate is also taken into account, the break-even point is about 15,000 phpdt. However, it may not be technically feasible to operate bus transport beyond 10,000 phpdt in the mixed transport scenario obtaining on Punecity roads.

The most likely peak traffic demand on PCMC – Swargate corridor has been assessed as 18110 PHPDT for 2011 and this is likely to increase to 20035 PHPDT by the year 2031. Similarly, on Vanaz – Ramvadi corridor the optimistic peak traffic demand has been assessed as 10048 PHPDT for 2011 and this is likely to increase to 22414 PHPDT by the year 2031. However, the most likely PHPDT values for the Vanaz- Ramvadi corridor in 2011 and 2031 are 5817 and 10982 respectively. Pollution in the city has already crossed the acceptable limit. Therefore, road based public transport will not serve the purpose and there is an urgent need to introduce a Metro system in the city to provide fast, safe and economic and environment friendly mode for mass movement of passengers.

3.2 TYPES OF METROS AND THEIR CAPACITY

Rail based mass transport in cities can be brought mainly under three categories:-

Mode		Carrying capacity (passengers/hour) phpdt
a)	Light Capacity Metro System i.e. Light Rail Capacity System (LRTS)	Up to 30,000
b)	Medium Capacity Metro System	30,000-50,000
c)	Heavy Capacity Metro System	50,000-80,000

Since, the number of commuters to be dealt is relatively less in Light Capacity Metro System, its trains consist of 3 to 4 Coaches (which can be increased to 6 Coaches in future) and other related infrastructure is also of a smaller size.

For medium capacity Metro system, the train generally comprises 3 to 6 coaches with ultimate train headway of about 3 minutes. The other related infrastructure, e.g. civil works; stations, passenger-handling equipment etc. are also planned accordingly.

Heavy capacity metro systems have to deal with large traffic densities ranging from 50,000 to 80,000 phpdt. Accordingly, the trains have 6 to 8 coaches and other related infrastructure is also of larger size. Beyond the traffic level of 80,000 phpdt, additional parallel lines are normally planned. The metro system being planned for Delhi is heavy capacity system.

In view of the present and projected phpdt on the proposed corridors of Pune city, a medium capacity Metro system is considered adequate to meet the traffic demand.

3.3 ADVANTAGES OF A METRO SYSTEM

Metro systems are superior to other modes because they provide higher carrying capacity, faster, smoother and safer travel, occupy less space, are non-polluting and energy-efficient. To summarise, a Metro system:

- (i) Requires 1/5th energy per passenger km compared to road-based system
- (ii) Causes no air pollution in the city
- (iii) Causes lesser noise level
- (iv) Occupies no road space if underground and only about 2 meters width of the road if elevated
- (v) Carries same amount of traffic as 5 lanes of bus traffic or 12 lanes of private motor cars (either way), if it is a medium capacity system.
- (vi) Is more reliable, comfortable and safer than road based system
- (vii) Reduces journey time by anything between 50% and 75% depending on road conditions.

Chapter - 4

System Selection



- 4.1 Consider for Selecting Light Metro System
- 4.2 Underground v/s Elevated Alignment
- 4.3 Permanent Way
- 4.4 Traction System
- 4.5 Signaling
- 4.6 Telecommunication
- 4.7 Automatic Fare Collection
- 4.8 Rolling Stock



CHAPTER 4

SYSTEM SELECTION

4.1 CONSIDERATION FOR SELECTING MEDIUM METRO SYSTEM

Traffic to be catered by metro services on PCMC –Swargate Corridor (16.589 km) and Vanaz- Ramwadi Corridor (14.665 km) in the years 2018, 2021, and 2031 has been discussed in detail in Chapter 2 on ‘Traffic Study’. It will be seen from this Chapter that peak hour peak direction trips (phpdt) on the proposed Corridors are given in Table 4.1.

Table 4.1 Peak Hour Peak Direction Traffic (PHPDT) Demand

Corridor	2018	2021	2031
Corridor -1 :PCMC - Swargate	1905	18961	20035
Corridor - 2:Vanaz – Ramwadi	6203	8519	10982

Road-based systems can optimally carry up to a maximum of 8,000 phpdt. Since the phpdt of the above proposed corridors exceed 8,000, it qualify for a rail-based Mass Transit System. A rail-based system may be either Light Capacity Metro System or Medium Capacity Metro System, or Heavy Capacity Metro System. While the Light Metro System is suitable for corridors with phpdt in the range of 15,000 to 30,000, medium capacity and heavy capacity Metro Systems can optimally handle traffic densities ranging between 30,000 - 50,000 phpdt and between 50,000 – 80,000 phpdt respectively.

Medium Capacity Metro System is to be adopted for Pune Metro System although the phpdt is below 30,000 even in 2031. The difference here in Light Metro and Medium Metro is only the planning of platforms for running 6 coach trains in place of 4 coach trains in LRT.

4.2 UNDERGROUND V/S ELEVATED ALIGNMENT

For the Metro System if the corridor is located on busy roads, underground alignment is preferable over the elevated alignment on numerous considerations. However, a single factor that tilts the balance in favour of the latter is its substantially lower construction cost, since a unit length of underground corridor, the cost involved is almost 3 times of that for an elevated alignment. In the present case as the proposed corridors have to traverse partly on wide roads and partly through highly congested area. Hence, the maximum portion of the

alignment has been planned elevated but small length as underground due the area being very congested with narrow roads.

4.3 PERMANENT WAY

4.3.1 Choice of Gauge

Standard Gauge (1435mm) is invariably used for metro railways world over. During the last decade, many metros such as Cairo, Madrid, Bangkok, Manila, and Beijing etc. have been constructed in various cities of the world. All these metros have gone in for Standard Gauge even though the national gauge for mainline railways in some of these countries was different from Standard Gauge. In India the national gauge is Broad Gauge (1676mm). The question whether PuneMetro should go in for Broad Gauge or Standard Gauge has, therefore, been examined with following important parameters.

- (i) Metro alignments in a city have to pass through heavily built-up areas for optimal passenger utilisation and this imposes severe restrictions on the selection of curves. As in most of the cities in India no 'right of way' has been reserved for metro systems, the alignments have to follow the major arterial roads. These roads may often have sharp curves and right-angle bends. In such a situation adoption of Standard Gauge is advantageous since it permits adoption of sharper curves compared to Broad Gauge to minimise property acquisition along the alignments.
- (ii) In Standard Gauge 1 in 7 and 1 in 9 turn-outs, which occupy lesser length, are feasible compared to 1 in 8 ½ and 1 in 12 turn-outs required for Broad Gauge. Length of cross-overs for Standard Gauge is thus lesser than for Broad Gauge. Land requirement for depots where a large number of lines connected together in the shape of ladder is also reduced. Standard Gauge is, therefore, more suited for use in built up environment where land availability is scarce.
- (iii) For Standard Gauge, optimised state-of-the-art rolling stock designs are available 'off-the-shelf'. This is not so for Broad Gauge where new designs for rolling stock have to be specially developed which entails extra time and cost.
- (iv) Because of the availability of a very large market, constant up-gradation of technology takes place for Standard Gauge coaches. Thus upgraded technology is available on a continued basis in case of Standard Gauge. This is not so in case of Broad Gauge.
- (v) For the same capacity gross weight of a metro coach is lower for Standard Gauge than for Broad Gauge. Standard Gauge rolling stock thus results in recurring saving in energy consumption during operation.
- (vi) Once technology for Standard Gauge coaches get absorbed and a manufacturing base for them is set up in India, there will be considerable export potential for the

coaches, since almost all the countries use Standard Gauge for their metros. This is not so in case of Broad Gauge.

- (vii) It is some time argued that adoption of Broad Gauge for metros would enable inter-running of metro trains with Indian Railways since the latter uses Broad Gauge. Inter-running is, however, technically and / or operationally not feasible as the two systems have different:
- Rolling Stock characteristics,
 - Signalling Systems,
 - Headways,
 - Tariffs,
 - Moving dimensions, and
 - Loading standards.
- (viii) Track gauge is not a technical parameter for any metro rail system. It is a planning parameter. This issue was also examined in January 2000 by the Ministry of Law and Justice who had opined that the choice of gauge is a matter which lies within the jurisdiction of the metro rail organisation entrusted with the responsibility of implementing and operating the metro systems.

Since inter-running is not feasible, choice of Gauge for a metro system should be based solely on technical and economic considerations on which Standard Gauge turns out to be superior.

From the above, it is seen that Standard Gauge will be cost-effective and at the same time enable PuneMetro to be at par with world-class metros and enable it to remain technically up-dated in future. Standard Gauge will also enable setting up a manufacturing base for coaches required for metros in other cities of the country as well create an export potential for such coaches. Adoption of Standard Gauge is, therefore, recommended for Pune Metro. A wider gauge is not justified for 2.9 m wide coach and axle loads are as low as 16 ton for Standard Gauge Metro.

4.3.2 TRACK STRUCTURE

Track on Metro Systems is subjected to intensive usage with very little time for day-to-day maintenance. Thus it is imperative that the track structure selected for Metro Systems should be long lasting and should require minimum or no maintenance and at the same time, ensure highest level of safety, reliability and comfort, with minimum noise and vibrations. The track structure has been proposed keeping the above philosophy in view.

General

Two types of track structures are proposed for any Metro. The normal ballasted track is suitable for At-Grade (surface) portion of Main Lines and in Depot (except inside the Workshops, inspection lines and washing plant lines. The ballast-less track is recommended on Viaducts and inside tunnels as the regular cleaning and replacement of ballast at such location will not be possible. Only in case of the depot normal ballasted track is proposed for adoption.

From considerations of maintainability, riding comfort and also to contain vibrations and noise levels, the complete track is proposed to be joint-less and for this purpose even the turnouts will have to be incorporated in LWR/CWR.

The track will be laid with 1 in 20 canted rails and the wheel profile of Rolling Stock should be compatible with the rail cant and rail profile.

Rail Section

Keeping in view the proposed axle load and the practices followed abroad, it is proposed to adopt UIC-60 (60 kg. /m) rail section. Since on main lines, sharp curves and steep gradients would be present, the grade of rail on main lines should be 1080 Head Hardened as per IRS-T- 12-96. As these rails are not manufactured in India at present, these are to be imported. For the Depot lines, the grade of rails should be 880, which can be easily manufactured indigenously.

Ballastless Track on Viaducts

On the viaducts, it is proposed to adopt plinth type ballastless track structure with RCC derailment guards integrated with the plinths (shown in **Fig.4.1**). Further, it is proposed to adopt fastenings System approved by the suitable system complying to performance criteria laid down by the Indian railways on both types of ballastless track structures, with a base-plate to base-plate spacing of 65 cm. on viaducts. Most of the components of Vossloh-336 fastening system are now indigenously available. The toe load design for the clips is to be finalised at the detail design stage.

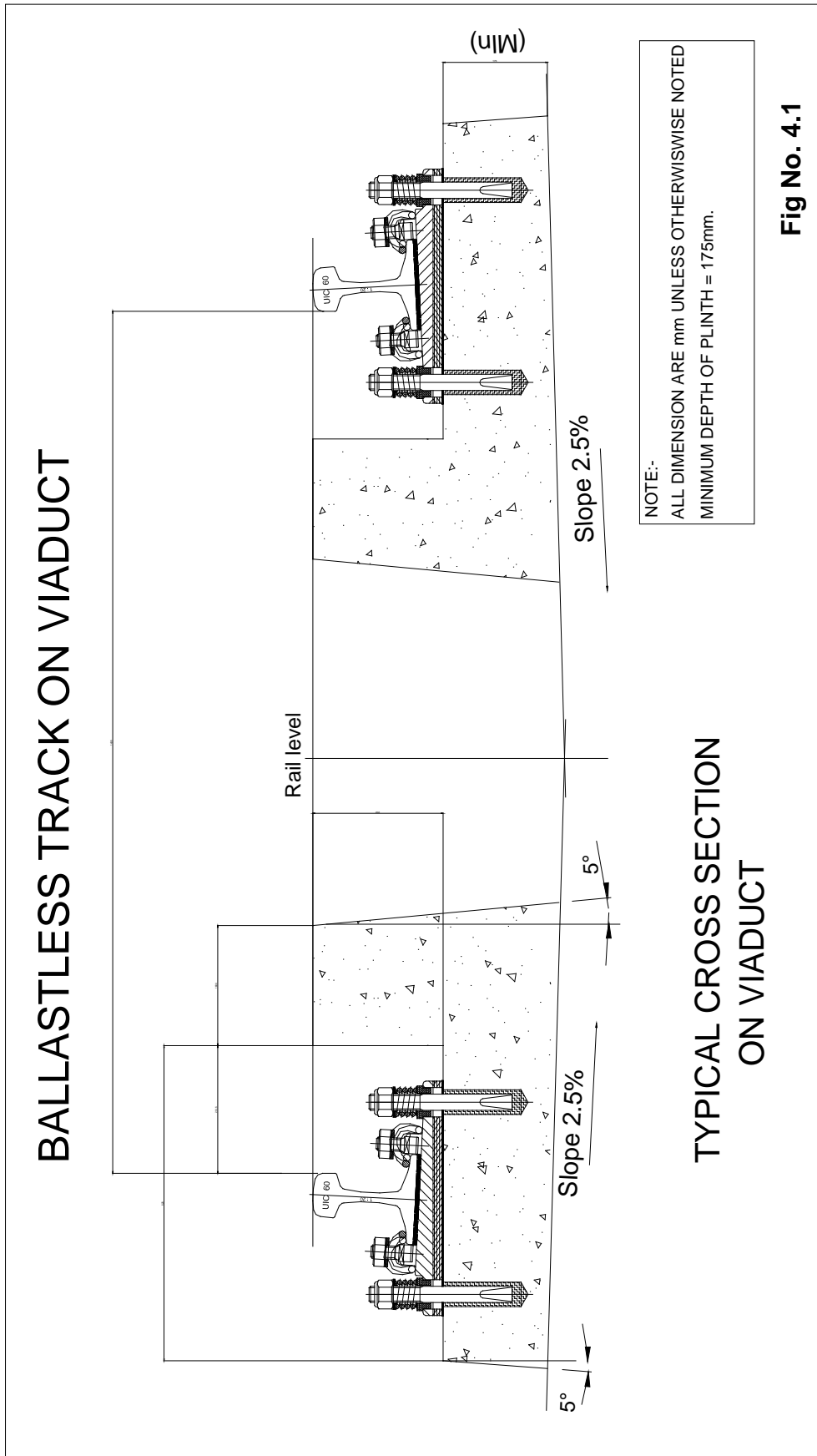
Ballast less Track in Depot

The ballastless track in Depot may be of the following types:

- Discretely supported on concrete/steel pedestal for inspection lines.
- Embedded rail type inside the Workshop.
- Plinth type for Washing Plant line.
- Normal Ballast less (as on viaduct) for Washing lines, Stabling and other running lines.

Turnouts

- From considerations of maintainability and riding comfort, it is proposed to lay the turnouts also with 1 in 20 cant. Further, it is proposed to adopt the following two types of turnouts:
 - i) On main lines, 1 in 9 type turnout with a lead radius of 300 metres and permissible speed on divergent track as 40 km/h (shown in **Fig.4.3**).
 - ii) On Depot lines, 1 in 7 type turnout with a lead radius of 400 metres and permissible speed on divergent track as 25 km/h (shown in **Fig.4.4**).
- The Scissors cross-overs on Main Lines (1 in 9 type) will be with a minimum track centre of 4.5 m (shown in **Fig.4.5**).
- The proposed specifications for turnouts are given below: -
 - i) The turnouts should have fan-shaped layout throughout the turnout so as to have same sleepers/base-plates and slide chairs for both LH and RH turnouts.
 - ii) The switches and crossings should be interchangeable between ballasted and ballastless turnouts (if required).
- The switch rail should be with thick web sections, having forged end near heel of switch for easy connection with lead rails, behind the heel of switch. The switches should have anti creep device at heel of switch for minimising the additional LWR forces transmitted from tongue rail to stock rail.
- The crossings should be made of cast manganese steel and with welded leg extensions. These crossings should be explosive hardened type for main lines and without surface hardening for Depot lines.
- The check rails should be with UIC-33 rail section without being directly connected to the running rails.



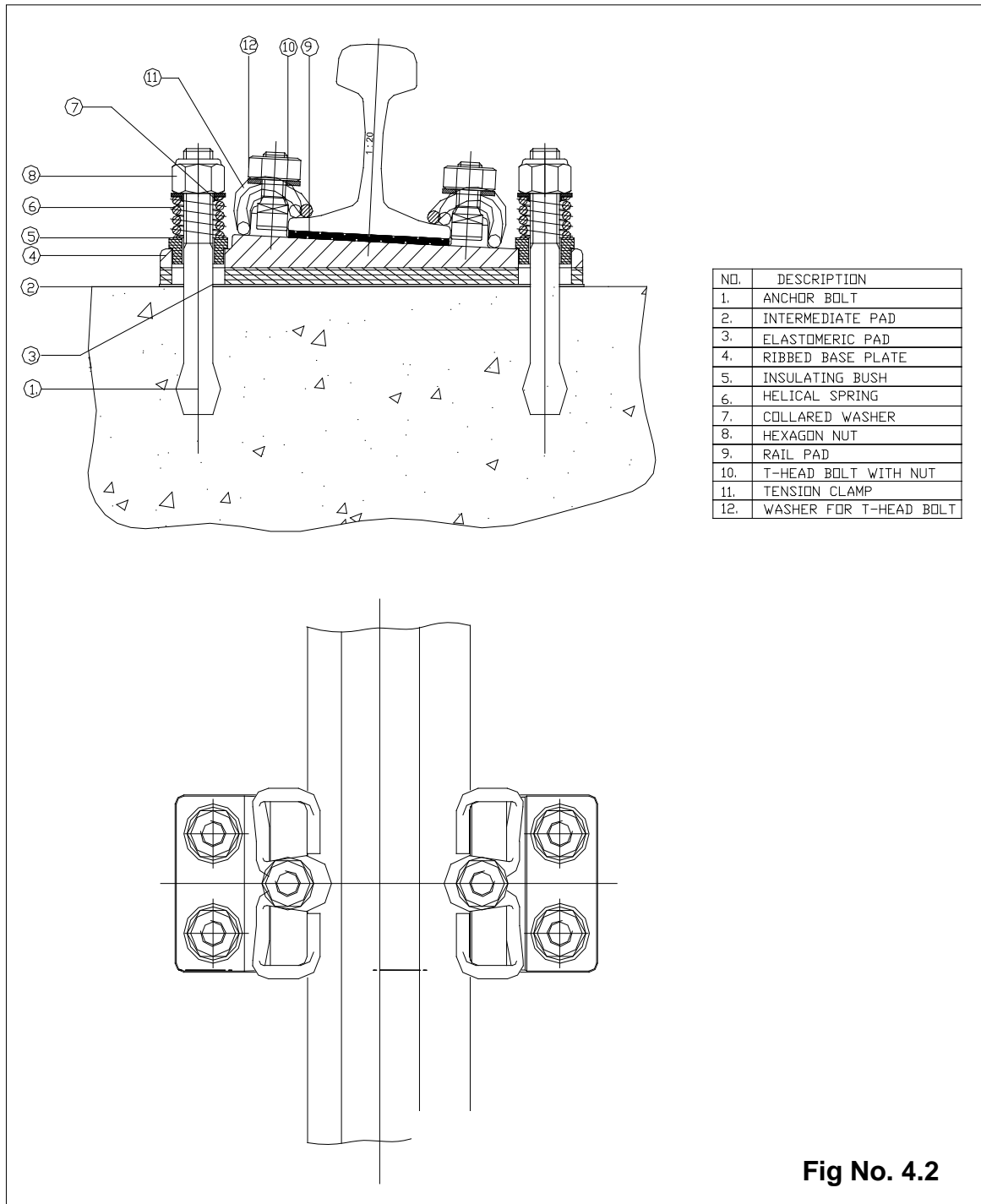


Fig No. 4.2

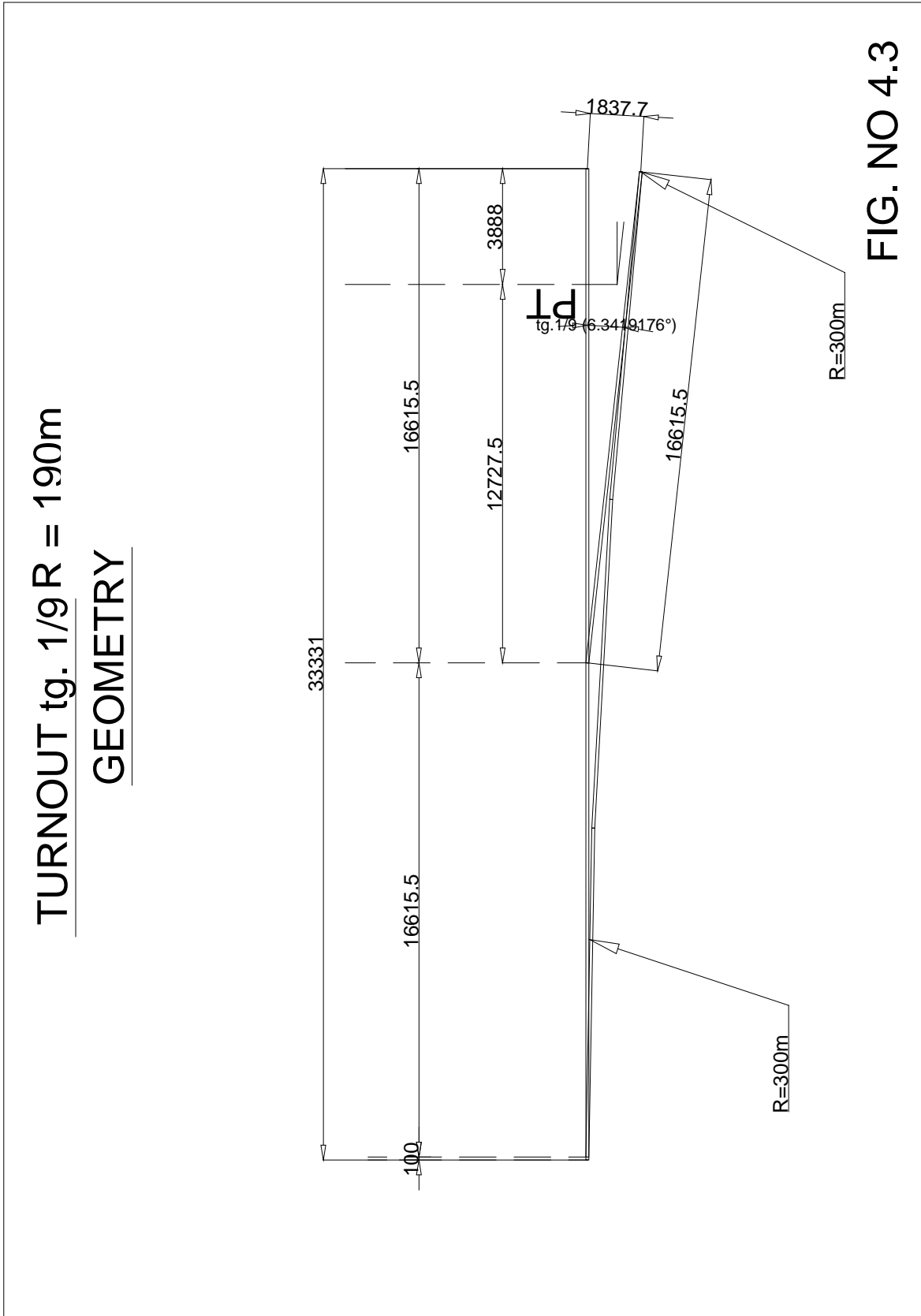


FIG. NO 4.3

TURNOUT tg. 1/7 R= 400m

GEOMETRY

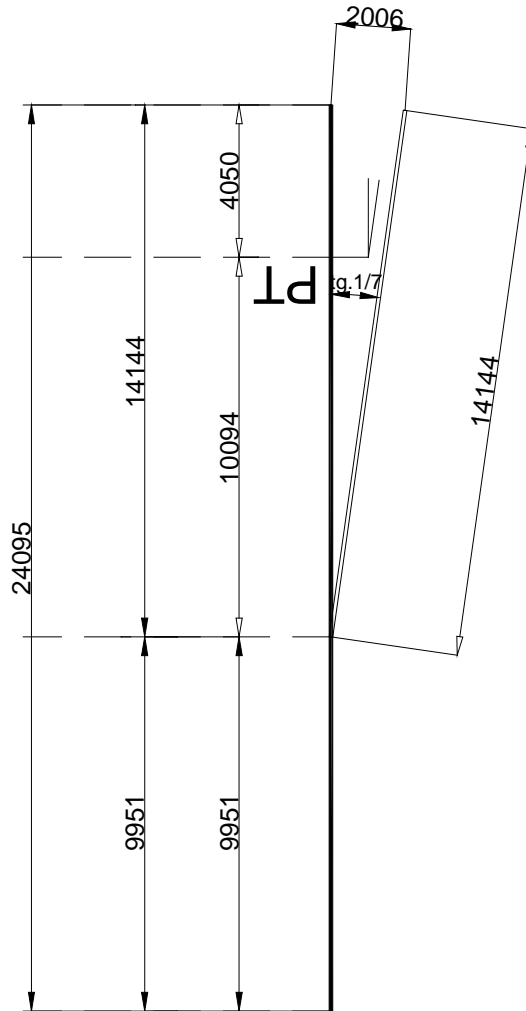


Fig No. 4.4

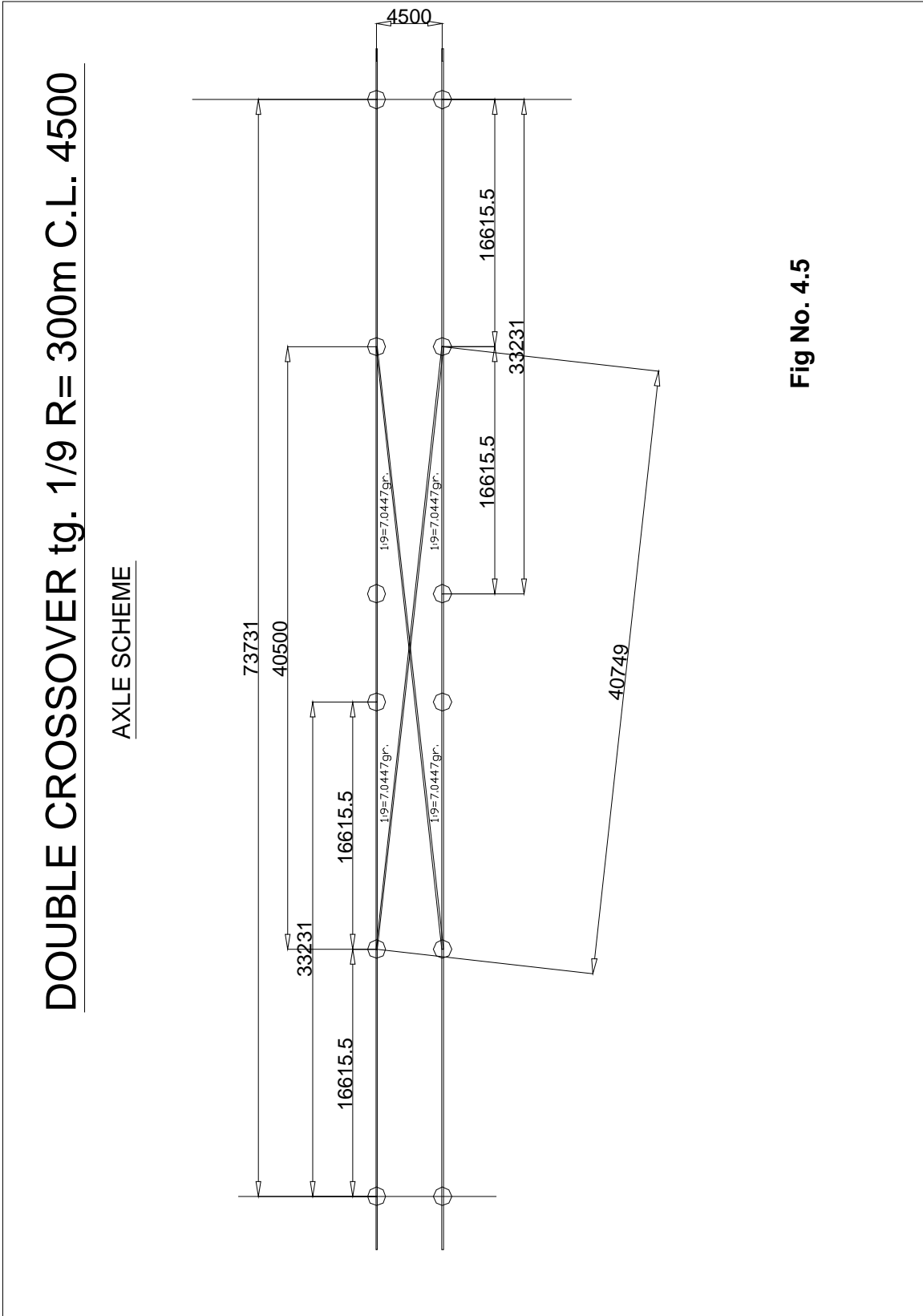


Fig No. 4.5

Buffer Stops

On main lines and Depot lines, friction buffer stops with mechanical impact absorption (non-hydraulic type) need to be provided. On elevated section the spans on which friction buffer stops are to be installed are to be designed for an additional longitudinal force of 85 T, which is likely to be transmitted in case of Rolling Stock impacting the friction Buffer Stops.

4.3.2 Rail Structure Interaction

For continuing the LWR/CWR on Viaducts, the elevated structures are to be adequately designed for the additional longitudinal forces likely to be transmitted as a result of Rail-Structure interaction. Rail structure interaction study will determine the need and locations of Rail Expansion Joints (REJ) also. REJ in ballasted track will be for a maximum gap of 120 mm, whereas on ballastless track for a maximum gap of 180 mm.

Welding

Flash Butt Welding Technique is to be used for welding of rails. Alumino-Thermic Welding is to be done only for those joints which cannot be welded by Flash Butt Welding Technique, such as joints at destressing locations and approach welds of switches & crossings. For minimising the population of Thermic welds, mobile (rail-cum-road or portable) Flash Butt Welding Plant will have to be deployed.

4.4 TRACTION SYSTEM

Traditionally, electric traction is used in Metro systems for requirement of high acceleration and pollution-free services in urban areas. There are three standard and proven systems of electric traction for use in suburban and metro lines, viz:- 750V dc third rail, 1500V dc overhead catenary and 25kV ac overhead catenary system. All these three systems are presently in use in India.

750V dc third rail system has been extensively used in metros and more than 60% of existing metro systems in the world utilize 600-750V dc third rail system. The system does not negate the aesthetics of the city as it is laid alongside the track and also requires smaller tunnel diameter for underground section compared to other systems. This system has a technical limitation beyond a traffic level of 60,000 PHPDT on account of requirement of large number of traction sub-stations and difficulty in differentiation between over-current and short-circuit currents. Few recently commissioned Metro systems with 750V dc third rail are Bangkok Subway (2005), Bangkok Transit System (1999), Ankaray Metro (1997), Athens Metro (2000), Istanbul Metro (2001) and Tehran Metro (2000). All these are Metro systems similar to the proposed Pune Metro.

1500V dc catenary system has been adopted by some of heavy metros to overcome the limitation imposed by 750V dc system for catering to traffic level of 60,000-80,000 PHPDT

(e.g. Singapore, Hong Kong, Guangzhou etc.). This system requires use of catenary masts and messenger wires on elevated viaducts thereby affecting aesthetics of the city.

Stray current corrosion is often encountered in dc-electrified railways and therefore, suitable measures are required for protection against corrosion of metallic structures, reinforcement and utility pipes caused by dc stray current.

25kV ac traction has the economical advantages of minimal number of traction sub-stations and potential to carry large traffic (60,000-90,000 PHPDT). The system requires catenary masts on surface/elevated section, thereby affecting aesthetics and skyline of the city. Suitable measures are required for mitigation of electro-magnetic interference (EMI) caused by single-phase 25kV ac traction currents. In addition, 25kV ac train will require heavy transformer & converters to be carried in each motor coach. A typical 25kV AC Catenary Arrangement is shown in Fig 4.6. Since the proposed alignment of Pune Metro would traverse congested roads and built-up area of the city, 25kV ac traction system is considered a safe option.



Fig 4.6 Typical 25kV AC Catenary Arrangement

Traffic requirements of the Pune Metro have been projected in the range of 25,000 PHPDT in year 2031. The alignment of proposed corridors is on elevated viaducts and some section of Corridor 1 is underground, where the height of structure has been restricted to less than 12 meter. Keeping in view the techno-economic considerations, 25 KV AC traction system is considered to be the best trade-off.

4.5 SIGNALLING

4.5.1 Introduction

The signaling system shall provide the means for an efficient train control, ensuring safety in train movements. It assists in optimization of metro infrastructure investment and running of efficient train services on the network.

4.5.2 Signalling and Train Control

4.5.2.1 Overview

Metro carries large number of passengers at a very close headway requiring a very high level of safety enforcement and reliability. At the same time heavy investment in infrastructure and rolling stock necessitates optimization of its capacity to provide the best services to the public. These requirements of the metro are planned to be achieved by adopting 'Distance to go' ATP (Automatic Train Protection) and ATS (Automatic Train Supervision) sub-systems. This will:

- Provide high level of safety with trains running at close headway ensuring continuous safe train separation.
- Eliminate accidents due to driver passing Signal at Danger by continuous speed monitoring and automatic application of brake in case of disregard of signal / warning by the driver.
- Provides safety and enforces speed limit on section having permanent and temporary speed restrictions.
- Improve capacity with safer and smoother operations. Driver will have continuous display of Target Speed / Distance to Go status in his cab enabling him to optimize the speed potential of the track section. It provides signal / speed status in the cab even in bad weather.
- Increased productivity of rolling stock by increasing line capacity and train speeds, and enabling train to arrive at its destination sooner. Hence more trips will be possible with the same number of rolling stock.
- Improve maintenance of Signaling and telecommunication equipments by monitoring system status of trackside and train born equipments and enabling preventive maintenance.

Signalling & Train Control system on the line shall be designed to meet the required headway during peak hours. Automatic Train Operation (ATO) is not planned initially but the system will be upgradeable to include ATO in future.

4.5.2.2 System Description and Specifications

The Signalling and Train Control system shall be as below. Sub-system/ components will conform to international standards like CENELEC, IEC, BS, IS, ITU-T etc:

A. Continuous Automatic Train Control

Continuous Automatic Train Control will consist of - ATP (Automatic Train Protection), ATO (Automatic Train Operation) and ATS (Automatic Train Supervision) sub-systems:

(i) Automatic Train Protection (ATP)

Automatic Train Protection is the primary function of the train control systems. This sub-system will be inherently capable of achieving the following objectives in a fail-safe manner. Line side signals will be provided at diverging routes (i.e. at points & crossings), which shall serve as backup signalling in case of failure of ATP system. However, in such cases, train speed will be automatically restricted to 25 kmph.

- Cab Signalling
- Track Related Speed Profile generation based on line data and train data continuously along the track
- Continuous monitoring of braking curve with respect to a defined target point
- Monitoring of maximum permitted speed on the line and speed restrictions in force
- Detection of over-speed with audio-visual warning and application of brakes, if necessary
- Maintaining safety distance between trains
- Monitoring of stopping point
- Monitoring of Direction of Travel and Rollback

The cab borne equipment will be of modular sub-assemblies for each function for easy maintenance and replacement. The ATP assemblies will be fitted in the vehicle integrated with other equipment of the rolling stock.

(ii) Automatic Train Operation (ATO) - Future

This system will operate the trains automatically from station to station while remaining within the safety envelope of ATP & open the train doors. Driver will close the train doors and press a button when ready to depart. In conjunction with ATP/ATS, ATO can control dwell time at stations and train running in accordance with headway/ timetable.

(ii) Automatic Train Supervision (ATS)

A train supervision system will be installed to facilitate the monitoring of train operation and also remote control of the station. The train supervision will log each train movement and display it on the workstations with each Traffic Controller at the OCC and on one workstation placed in the Station Control room (SCR) with each Station Controller.

The centralized system will be installed in the Operation Control Centre. The OCC will have a projection display panel showing a panoramic view showing the status of tracks, points, signals and the vehicles operating in the relevant section/ whole system. ATS will provide following main functionalities:

- Automatic Route setting
- Automatic Train Regulation
- Continuous Tracking of train position
- Display Panel & Workstation interface
- Adjustment of station dwell time
- Link to Passenger Information Display System for online information
- Computation of train schedules & Timetable

B. Interlocking System:**(i) Computer Based Interlocking (CBI)**

At all stations with points and crossings, Computer Based Interlocking (CBI) will be provided for operation of points and crossings and setting of routes.

The setting of the route and clearing of the signals will be done by workstation, which can be either locally (at station operated or operated remotely from the OCC).

This sub-system is used for controlling vehicle movements into or out of stations automatically from a workstation. All stations having points and crossings will be provided with workstations for local control. Track occupancy, point position, etc. will be clearly indicated on the workstation. It will be possible to operate the workstation locally, if the central control hands over the operation to the local station. The interlocking system design will be on the basis of fail-safe principle.

The equipment will withstand tough environmental conditions encountered in a Mass Transit System. Control functions in external circuits will be proved both in the positive and negative wires. Suitable IS, IRS, BS standards or equivalent

international standards will be followed in case wiring, installation, earthing, cabling, power supply and for material used in track circuits, relays, point operating machines, power supply etc.

(ii) Track Circuits

Audio Frequency Track Circuit will be used for vehicle detection and for transmission of data from track to train.

(ii) Point Machines

Non-Trailable Electrical Point Machine capable of operating with either 110V DC or 3-phase 380V AC will be used on main line. The depot point machine will preferably be trailable type.

C. Train Depot: Signalling

Two depots i.e. one near Hill Range Station in Agricultural University area and another near Vanaz Station area are planned for Corridor 1 & 2 respectively. All depot lines except the ones used for shunting and in workshop shall be interlocked. A workstation each shall be provided in the Depot Control Centre for electrical operation of the points, signals and routes of the depot yard. Audio Frequency Track Circuits will be used in the depot as well.

4.5.2.3 Standards

The standards to be adopted for Signalling system are shown in Table 4.2.

Table 4.2 Standards of Signalling System

Description	Standards
<ul style="list-style-type: none"> ▪ Interlocking 	Computer based Interlocking adopted for station having switches and crossing. All related equipment as far as possible will be centralised in the equipment room at the station. The depot shall be interlocked except for lines mainly used for shunting, workshop/inspection shed areas.
<ul style="list-style-type: none"> ▪ Operation of Points 	With Direct current 110V D.C. point machines or 380 volts 3 phase, 50 Hz. AC point machines.
<ul style="list-style-type: none"> ▪ Track Circuit 	Audio frequency Track circuits on running section, test track and in depot.
<ul style="list-style-type: none"> ▪ Signals at Stations with point & crossings 	Line Side signals to protect the points (switches). LED type signals for reliability and reduced maintenance cost.

Description	Standards
<ul style="list-style-type: none"> UPS (uninterrupted power at stations as well as for OCC) 	For Signalling and Telecommunications
<ul style="list-style-type: none"> Train protection system 	Automatic Train Protection system.
<ul style="list-style-type: none"> Train Describer System 	Automatic Train Supervision system. Movement of all trains to be logged on to a central computer and displayed on workstations in the Operational Control Centre and at the SCR. Remote control of stations from the OCC.
<ul style="list-style-type: none"> Redundancy for TP/ Train Describer. 	Redundant Train borne equipment and ATS equipment at OCC.
<ul style="list-style-type: none"> Cables 	Outdoor cables will be steel armoured as far as possible.
<ul style="list-style-type: none"> Fail Safe Principles 	SIL-4 safety levels as per CENELEC standard for signal application.
<ul style="list-style-type: none"> Immunity to External Interface. 	All data transmission on telecom cables/OFC/Radio. All Signalling and telecom cables will be separated from power cables. CENELEC standards to be implemented for EMC.
<ul style="list-style-type: none"> Train Working under emergency 	Running on site with line side signal with speed automatically restricted between 15-25 kmph.
<ul style="list-style-type: none"> Environmental Conditions 	Air-conditioners for all equipment rooms.
<ul style="list-style-type: none"> Maintenance philosophy 	Philosophy of continuous monitoring of system status and preventive & corrective maintenance of Signalling equipments shall be followed. Card / module / sub-system level replacement shall be done in the field and repairs under taken in the central laboratory/ manufacturer's premises.

4.5.3 Space Requirement for Signalling Installations

Adequate space for proper installations of all Signalling equipment at each of the stations has to be provided keeping in view the case of maintenance and use of instrumentation set up for regular testing and line up of the equipment/system. The areas required at each of the stations for Signalling equipment shall be generally 50 sqm for UPS Room (common for signalling and telecom) and 50 sqm at interlocked station with points & 20 sqm at other stations for Signalling. These areas shall also cater to local storage and space for maintenance personnel to work. At the OCC and the Depot, the areas required shall be as per the final configuration of the equipments and network configuration keeping space for further expansion.

4.5.4 Maintenance Philosophy for Signalling systems

The philosophy of continuous monitoring of system status and preventive & corrective maintenance of Signalling and telecommunication equipments shall be followed. Card / module / sub-system level replacement shall be done in the field. Maintenance personnel shall be suitably placed at intervals and they shall be trained in multidisciplinary skills. Each team shall be equipped with a fully equipped transport vehicle for effectively carrying out the maintenance from station to station.

The defective card/ module / sub-system taken out from the section shall be sent for diagnostic and repair to a centralized S&T repair lab suitably located on the section. This lab will be equipped with appropriate diagnostic and test equipments to rectify the faults and undertake minor repairs. Cards / modules / equipments requiring major repairs as specified in suppliers documents shall be sent to manufacturer's workshop.

4.6 TELECOMMUNICATION

4.6.1 Introduction

The telecommunication system acts as the communication backbone for Signalling systems and other systems such as SCADA, AFC etc and provides telecommunication services to meet operational and administrative requirements of metro network.

5.6.2 Telecommunication

4.6.2.1 Overview

The telecommunication facilities proposed are helpful in meeting the requirements for

1. Supplementing the Signalling system for efficient train operation.
2. Exchange of managerial information
3. Crisis management during emergencies
4. Passenger information system

The proposed telecom system will cater to the following requirements:

- Train Traffic Control
- Assistance to Train Traffic Control
- Maintenance Control
- Emergency Control
- Station to station dedicated communication

- Telephone Exchange
- Passenger Announcement System and Passenger Information and Display System within the station and from Central Control to each station.
- Centralised Clock System
- Train Destination Indicator
- Instant on line Radio Communication between Central Control and Moving Cars and maintenance personnel.
- Data Channels for Signalling, SCADA, Automatic Fare Collection etc.

4.6.2.3 Telecommunication System and Transmission Media

i) **Fibre Optic System - Main Telecommunication Bearer**

The main bearer of the bulk of the telecommunication network is proposed with optical fibre cable system. Considering the channel requirement and keeping in view the future expansion requirements a 24fibre optical fiber cable is proposed to be laid in ring configuration with path diversity.

SDH(minimumSTM-4) based system shall be adopted with SDH nodes at every station and OCC. Access 2MB multiplexing system will be adopted for the lower level at each node, equipped for channel cards depending on the requirement of channels in the network. Further small routers and switches shall be provided for LAN network at stations. Alternatively a totally IP Based High Capacity Ethernet Network can be provided in lieu of SDH/MUX.

ii) **Telephone Exchange**

For an optimized cost effective solution Small exchanges of 30 port each shall be planned at each station , a 60 Port Exchange at the Terminal Stations and a 100 Port exchanges at the OCC/Depots. The Exchanges will serve the subscribers at all the stations and OCC. The exchanges will be interconnected at multiple 2 MB level through optical fibre cable. The Exchanges shall be software partitioned for EPABX and Direct Line Communication from which the phones shall be extended to the stations.

iii) **Mobile Radio Communication**

Mobile Radio communication system having 8 logical channels is proposed for on-line emergency communication between Motorman (Front end and Rear end) of moving train and the Central Control. The system shall be based on Digital Trunk Radio Technology to TETRA International standard. This system now is widely adopted for mobile radio communication in metro / rapid transit services abroad. All the stations and the OCC will be provided with fixed radio sets. Mobile communication facility for maintenance parties and Security Personnel will be provided with handheld sets.

These persons will be able to communicate with each other as well as with central control.

The frequency band for operation of the system will be that for TETRA in 400/800 MHz band, depending on frequency availability.

The system shall provide Instant mobile radio communication between the motorman of the moving cars from any place and the Central Control .The motorman can also contact any station in the network through the central control, besides intimating the approaching trains about any emergency like accident, fire, line blocked etc., thus improving safety performance.

To provide adequate coverage, based on the RF site survey to be carried out during detailed design stage, base stations for the system will be located at sites conveniently selected after detailed survey. Tentatively 3 sites with 40 m towers and 1 Base Station for underground stations shall be required along the route for corridor 1 and 4 Base Station sites with 40 m towers for corridor 2.

iv) Passenger Announcement System

The system shall be capable of announcements from the local station as well as from OCC. Announcements from OCC will have over-riding priority in all announcements.

v) Centralised Clock System

This will ensure an accurate display of time through a synchronization system of slave clocks driven from a Master Clock at the operation control center. The Master Clock signal shall also be required for synchronization of SDH and Exchanges. The System will ensure identical display of time at all locations. Clocks are to be provided at platforms, concourse, Station Master's Room, Depots and other service establishments etc.

vi) Passenger Information Display System

These shall be located at convenient locations at all stations to provide bilingual visual indication of the status of the running trains and will typically indicate information such as destination, arrival/departure time, and also special messages in emergencies. The boards shall be provided at all platforms and concourses of all stations.

vii) Network Monitoring and Management

For efficient and cost effective maintenance of the entire communication network, it is proposed to provide a network management system (NMS), which will help in diagnosing faults immediately from a central location and attending the same with

least possible delay, thus increasing the operational efficiency and reduction in manpower requirement for maintenance.

The proposed NMS system will be covering radio communication, Optical Fiber Transmission system and Telephone Exchange.

4.6.2.4 Standards

The standards proposed to be adopted for telecommunication systems are shown in Table 4.3.

Table 4.3 Standards of Telecommunication System

System	Standards
<ul style="list-style-type: none"> Transmission System 	SDH based for the entire telecom network.
<ul style="list-style-type: none"> Transmission Media 	Optical Fibre system as the main bearer for bulk of the telecommunication network,
<ul style="list-style-type: none"> Telephone Exchange 	EPABX of minimum 30 ports is to be provided at all Stations , an Exchange of 60 Ports to be provided at Terminal Station.
<ul style="list-style-type: none"> Train Radio System 	Digital Train radio (TETRA) communication between motorman of moving cars, stations, maintenance personnel, depots and central control.
<ul style="list-style-type: none"> Train Destination Indicator System 	LED/LCD based boards with adequate visibility to be provided at convenient location at all stations to provide bilingual visual indication of the status of the running trains, and also special messages in emergencies.
<ul style="list-style-type: none"> Centralized clock system 	Accurate display of time through a synchronisation system of slave clocks driven from a master clock at the OCC and sub – master clock in station/depots.. This shall also be used for synchronisation other systems.
<ul style="list-style-type: none"> Passenger Announcement System 	Passenger Announcement System covering all platform and concourse areas with local as well as Central Announcement.
<ul style="list-style-type: none"> Redundancy (Major System) 	Redundancy on Radio base station equipment. Path Redundancy for Optical Fibre Cable by provisioning in ring configuration.
<ul style="list-style-type: none"> Environmental Conditions 	All equipment rooms to be air-conditioned.

System	Standards
<ul style="list-style-type: none"> Maintenance Philosophy 	System to have, as far as possible, automatic switching facility to alternate routes/circuits in the event of failure. Philosophy of preventive checks of maintenance to be followed. System networked with NMS for diagnosing faults and co-ordination. Card/module level replacement shall be done in the field and repairs undertaken in the central laboratory/manufacture's premises.

4.6.3 Space Requirement for Telecom Installations

Adequate space for proper installations of all Telecommunication equipment at each of the stations has to be provided keeping in view the case of maintenance and use of instrumentation set up for regular testing and line up of the equipment/system. The areas required at each of the stations for S & T equipment shall be generally 40 sq.m each for Telecom Room and 50 sq.m. for UPS Room (common for signal, telecom and AFC). These areas shall also cater to local storage and space for maintenance personnel to work. At the OCC, the areas required shall be as per the final configuration of the equipments and network configuration keeping space for further expansion.

4.6.4 Maintenance Philosophy for Telecom systems

The philosophy of continuous monitoring of system status and preventive & corrective maintenance of Signalling and telecommunication equipments shall be followed. Card / module / sub-system level replacement shall be done in the field. Maintenance personnel shall be suitably placed at intervals and they shall be trained in multidisciplinary skills. Each team shall be equipped with a fully equipped transport vehicle for effectively carrying out the maintenance from station to station.

The defective card/ module / sub-system taken out from the section shall be sent for diagnostic and repair to a centralized S&T repair lab suitably located on the section. This lab will be equipped with appropriate diagnostic and test equipments to rectify the faults and undertake minor repairs. Cards / modules / equipments requiring major repairs as specified in suppliers documents shall be sent to manufacturer's workshop.

4.7 AUTOMATIC FARE COLLECTION

4.7.1 Introduction

Metro Rail System handle large number of passengers. Ticket issue and fare collection play a vital role in the efficient and proper operation of the system. To achieve this objective, ticketing system shall be simple, easy to use/operate and maintain, easy on accounting

facilities, capable of issuing single/multiple journey tickets, amenable for quick fare changes and require overall lesser manpower. In view of above, computer based automatic fare collection system is proposed.

The proposed Ticketing system shall be of Contactless Smart Card & Token type. For Multiple Journey , the Store Value Smart Card shall be utilized and for the Single Journey , the Smart Token , which shall be captured by the gate at the exits, shall be utilized.

AFC system proves to be cheaper than semi-automatic (manual system) in long run due to reduced manpower cost for ticketing staff, reduced maintenance in comparison to paper ticket machines, overall less cost of recyclable tickets (Smart Card/Token) in comparison to paper tickets and prevention of leakage of revenue.

Relative advantages of automatic fare collection system over manual system are as follows:

A) Manual fare collection systems have the following inherent disadvantages:

1. Large number of staff is required for issue and checking of tickets.
2. Change of fare structure is time consuming as has to be done at each station.
3. Manipulation possible by jamming of mechanical parts.
4. Staff and passenger interaction leading to more chances of confrontation.
5. 100% ticket checking at entry / exit impossible.

B) Automatic fare collection systems have the following advantages:

1. Less number of staff required.
2. Less possibility of leakage of revenue due to 100% ticket check by control gates.
3. Recycling of ticket fraudulently by staff avoided.
4. Efficient and easy to operate, faster evacuation both in normal and emergency.
5. System is amenable for quick fare changes.
6. Management information reports generation easy.
7. System has multi-operator capabilities. Same Smart Card can be used for other applications also,
8. AFC systems are the worldwide accepted systems for Metro environment.

The proposed ticketing system shall be of Contact less Smart Token/ Card type. The equipments for the same shall be provided at each station Counter/Booking office and at convenient locations and will be connected to a local area network with a computer in the Station Master's Room.

C) Choice of Control Gates

Retractable flap type Control Gates are proposed which offer high throughput , require less maintenance and are latest in modern metros internationally. Tripod turnstile type or flap type gates offer less throughput and require more maintenance.

D) Passenger Operated Machine

At all the Stations, two Passenger Operated Machines (Automatic Ticket Vending Machines) each are proposed. The POM's will provide convenience to passengers to avoid standing in queues at ticket booths and provide them international standard service.

Standards

The standards proposed to be adopted for AFC systems are shown in Table 4.4.

Table 4.4 Standards of Automatic Fare Collection System

Standards	Description
<ul style="list-style-type: none"> Fare media 	a) Contactless smart token – For single journey. They shall have stored value amount for a particular journey. Tokens are captured at the exit gate. b) Contactless smart card – For multiple journeys.
<ul style="list-style-type: none"> Gates 	Computer controlled retractable flap type automatic gates at entry and exit. There will be following types of gates : <ul style="list-style-type: none"> Entry Exit Reversible – can be set to entry or exit Wide reversible -gate for disabled people.
<ul style="list-style-type: none"> Station computer, Central computer and AFC Net work 	All the fare collection equipments shall be connected in a local area network with a station server controlling the activities of all the machines. These station servers will be linked to the central computer situated in the operational control centre through the optic fibre communication channels. The centralised control of the system shall provide real time data of earnings, passenger flow analysis, blacklisting of specified cards etc.
<ul style="list-style-type: none"> Ticket office machine (TOM/EFO) 	Manned Ticket office machine shall be installed in the stations for selling cards/ tokens to the passengers.
<ul style="list-style-type: none"> Ticket reader and portable ticket decoder. 	Ticket reader shall be installed near EFO for passengers to check information stored in the token / cards.

Standards	Description
<ul style="list-style-type: none"> UPS (uninterrupted power at stations as well as for OCC). 	Common UPS of S&T system will be utilized.
<ul style="list-style-type: none"> Maintenance philosophy 	Being fully Contactless systems, manpower requirement for maintenance is much less compared to system with magnetic tickets. However, adequate facilities to be provided similar to that of S&T systems.

4.7.2 AFC Equipment Requirements

AFC equipment requirements are given in Table 4.5 below.

Table 4.5 AFC Equipment Requirements

Station	Daily Boarding	Daily Alighting	Gate			Disabled Gate	TOM	EFO	TR	POM
			Entry	Exit	Reversible					
CORRIDOR-I DETAILS OF AFC EQUIPMENT										
PCMC	11250	10272	2	2	2	1	4	2	4	2
Tukaram Nagar	2486	3146	2	2	2	1	4	2	4	2
Bhosari (Nashik Phata)	767	1219	2	2	2	1	4	2	4	2
Kasarwadi	1609	3596	2	2	2	1	4	2	4	2
Fugewadi	216	345	2	2	2	1	4	2	4	2
Dapodi	2876	2841	2	2	2	1	4	2	4	2
Bopodi	2196	1981	2	2	2	1	4	2	4	2
Khadki	987	289	2	2	2	1	4	2	4	2
Range Hill	4219	3618	2	2	2	1	4	2	4	2
Shivaji Nagar	1548	1215	2	2	2	1	4	2	4	2
ASI	8978	6125	2	2	2	1	4	2	4	2
PMC	4157	5419	2	2	2	1	4	2	4	2
BudhwarPeth	1715	3002	2	2	2	1	4	2	4	2
Mandai	660	8482	2	2	2	1	4	2	4	2
Swargate	18848	10961	2	2	2	1	4	2	4	2
		TOTAL	30	30	30	15	60	30	60	30
CORRIDOR-II DETAILS OF AFC EQUIPMENT										
Vanaz	4854	2828	2	2	2	1	4	2	4	2
Anand Nagar	458	155	2	2	2	1	4	2	4	2
Ideal Colony	22	67	2	2	2	1	4	2	4	2
Nal Stop	4492	4725	2	2	2	1	4	2	4	2
Garware College*	1312	1472	2	2	2	1	4	2	4	2

Station	Daily	Daily	Gate			Disabled	TOM	EFO	TR	POM
Deccan*	5493	6295	2	2	2	1	4	2	4	2
ASI*	1005	1622	2	2	2	1	4	2	4	2
Civil Court*	3984	5777	2	2	2	1	4	2	4	2
MangalwarPeth	1755	2276	2	2	2	1	4	2	4	2
Sasson	1519	1665	2	2	2	1	4	2	4	2
Pune Railway Station	3769	3487	2	2	2	1	4	2	4	2
Ruby Clinic	1103	517	2	2	2	1	4	2	4	2
Bund Garden	1783	1290	2	2	2	1	4	2	4	2
Yerawada	1676	1451	2	2	2	1	4	2	4	2
Kalyani Nagar	3206	3196	2	2	2	1	4	2	4	2
Ramwadi	1483	1464	2	2	2	1	4	2	4	2
		TOTAL	32	32	32	16	64	32	64	32

*Between Garware college & City civil court 3 stations proposed (Deccan, Sambhaji park & PMC)

Assumptions:

1. Each station has two accesses.
2. Minimum arrangement at each access is 1 entry gate, 1 exit gate, 1 reversible gate, 1 EFO and 2 TR.
3. Throughput of gate is 30 PPM. For TOM it is 10 PPM.
4. 50% passengers are assumed on smart card and 50% on single journey token.
5. Each station has 1 wide gate for disabled. Exact equipment arrangement depends on final station layout.

4.8 ROLLING STOCK

4.8.1 Introduction

The required transport demand forecast is the governing factor for the choice of the Rolling Stock. In a metro city, the forecasted Peak Hour Peak Direction Traffic (PHPDT) calls for a Medium Rail Transit System.

4.8.2 Optimization of Coach Size

The following optimum size of the coach has been chosen for this corridor as mentioned in Table 4.6.

Table 4.6 - Size of the coach

Description	Length*	Width	Height
Driver Trailer Car	21.64 m	2.9 m	3.9 m
Motor/Trailer car	21.34 m	2.9 m	3.9 m

* Maximum length of coach over coupler/buffers = 22.6 m.

4.8.3 Passenger Carrying Capacity

In order to maximize the passenger carrying capacity, longitudinal seating arrangement shall be adopted. The whole train shall be vestibuled to distribute the passenger evenly in all the coaches and for evacuation from ends in emergency. Criteria for the calculation of standing passengers are 3 persons per square meter of standing floor area in normal state and 6 persons in crush state of peak hour.

Therefore, for the Medium Rail Vehicles (MRV) with 2.9 m maximum width and longitudinal seat arrangement, conceptually the crush capacity of 43 seated, 204 standing thus a total of 247 passengers for a Driving Trailer Car and 50 seated, 220 standing, thus a total of 270 for a Trailer/ Motor Car is envisaged.

Following train composition is recommended :

4-car Train : DTC+MC+MC+DTC

6-car Train : DTC+MC+TC+MC+MC+DTC

The passenger carrying capacity for Driving Trailer Car, Trailer Car and Motor Car and also of a train is given in table 4.7.

Table 4.7 - Carrying Capacity of MRV

	DTC		TC / MC		4-Car Train		6-Car Train	
	Normal	Crush	Normal	Crush	Normal	Crush	Normal	Crush
Seated	43	43	50	50	186	186	286	286
Standing	102	204	110	220	424	848	644	1288
Total	145	247	160	270	610	1034	930	1574

Normal- 3 persons/sqm of standee area

Crush - 6 persons/sqm of standee area

4.8.3 Weight

The weight of motorcars and trailers has estimated as in Table 4.8, referring to the experiences in Delhi Metro. The average passenger weight has been taken as 65 kg.

Table 4.8 -Weight of Light Rail Vehicles (Tonnes)

Description	DTC	TC	MC	4-Car Train	6-Car Train	8-Car Train
TARE(max)	39	39	39	156	234	312
Passenger						
Normal	9.425	10.4	10.4	39.65	60.45	81.25
Crush@6/sqm	16.055	17.55	17.55	67.21	102.31	137.41
Crush@8/sqm	20.475	22.295	22.295	85.583	130.22	174.85

Description	DTC	TC	MC	4-Car Train	6-Car Train	8-Car Train
Gross						
Normal	48.25	49.4	49.4	195.65	294.45	393.25
Crush@6/sqm	55.055	56.55	56.55	223.21	336.31	449.41
Crush@8/sqm	59.475	61.295	61.295	241.58	364.22	486.85
Axle Load Crush@6/sqm	13.764	14.138	14.138			
Axle Load Crush@8/sqm	14.869	15.324	15.324			

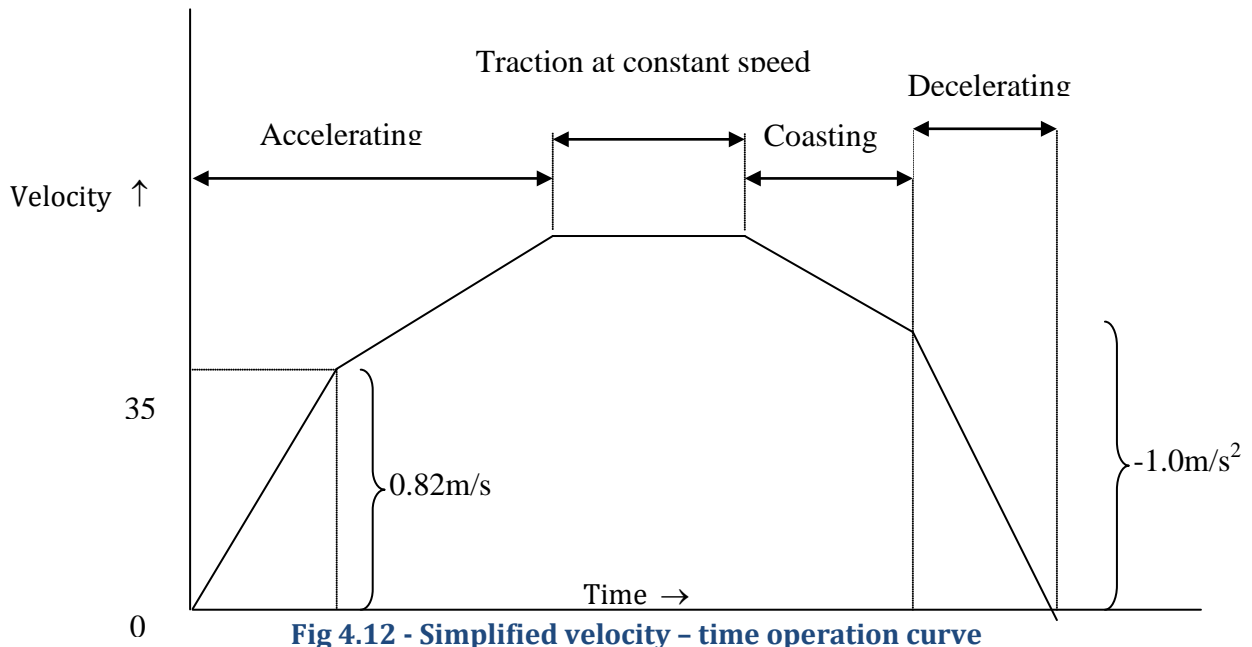
The axle load @ 6 persons/ sqm of standing area works out in the range of 13.764T to 14.138 T. Heavy rush of passenger, having 8 standees per sq. meter can be experienced occasionally. Hence, it will be advisable to design the coach with sufficient strength so that even with this overload, the design will not result in over stresses in the coach. Coach and bogie should therefore be designed for 16 T axle load.

4.8.5 Performance Parameters

It would be necessary for the trains to have rather higher acceleration and deceleration, considering the short distance between stations along the line. The recommended performance parameters are:

Maximum Design Speed	:	95 kmph
Maximum Service Speed	:	85 kmph
Acceleration	:	0.82 m/s ² +_ 5%
Deceleration	:	1.1 m/s ² (normal brake)
	:	1.3 m/s ² (Emergency brake)

Simplified velocity – time operation curve is shown in Fig 4.12



4.8.6 Coach design and basic parameters

The important criteria for selection of rolling stock are as under:

- Proven equipment with high reliability.
- Passenger safety feature
- Energy efficiency
- Light weight equipment and coach body
- Optimized scheduled speed
- Aesthetically pleasing Interior and Exterior
- Low Life cycle cost
- Flexibility to meet increase in traffic demand
- Anti-telescopic

The controlling criteria are reliability, low energy consumption, lightweight and high efficiency leading to lower annualized cost of service. The coach should have high rate of acceleration and deceleration.

4.8.7 Selection of Technology

Low life cycle cost:

The low life cycle cost is achieved by the way of reduced scheduled and unscheduled maintenance and high reliability of the sub-systems. It is possible to achieve these objectives by adopting suitable proven technologies. The selection of following Technologies has been adopted to ensure low life cycle cost:

4.8.8 Car body

In the past carbon high tensile steel was invariably used for car bodies. In-fact almost all the coaches built by Indian Railways are of this type. These steel bodied coaches need frequent painting as well corrosion repairs, which may have to be carried out up to 4-5 times during the service life of these coaches. It is now standard practice to adopt stainless steel or aluminium for car body.

The car bodies with aluminium require long and complex extruded sections which are still not manufactured in India. Therefore, aluminium car body has not been considered for use. Stainless steel sections are available in India and as such it is specified. No corrosion repair is necessary on these cars during their service life.

Stainless steel car body leads to energy saving due to its light weight. It also results in cost saving due to easy maintenance and reduction of repair cost from excellent anti-corrosive properties as well as on improvement of riding comfort and safety in case of a crash or fire.

4.8.9 Bogies

Bolster less lightweight bogies with rubber springs are now universally adopted in metro cars. These bogies require less maintenance and overhaul interval is also of the order of 4,20,000km. The use of air spring at secondary stage is considered with a view to keep the floor level of the cars constant irrespective of passenger loading unlike those with coil spring. The perturbation from the track are also dampened inside the car body on account of the secondary air spring along with suitable Vertical Hydraulic Damper. The primary suspension system improves the curve running performance by reducing lateral forces through application of conical rubber spring. A smooth curving performance with better ride index is being ensured by provision of above type of bogies.

4.8.10 Braking System

The brake system shall consist of:

- An electro-pneumatic (EP) service friction brake.

- A fail safe, pneumatic friction emergency brake.
- A spring applied air-release parking brake
- An electric regenerative service brake
- Provision of smooth and continuous blending of EP and regenerative braking.

The regenerative braking will be the main brake power of the train and will regain the maximum possible energy and pump it back to the system and thus fully utilize the advantage of 3 phase technology .The regenerative braking should have air supplement control to bear the load of trailer car. In addition, speed sensors mounted on each axle control the braking force of the axles with anti skid valves, prompting re-adhesion in case of a skid.The brake actuator shall operate either a tread brake or a wheel disc brake.

4.8.11 Propulsion System Technology

In the field of Electric Rolling Stock, DC series traction motors have been widely used due to its ideal characteristics and good controllability for traction applications. But these required intensive maintenance because of commutators and electro-mechanical contactors, resistors etc.

The brushless 3 phase induction motors has now replaced the D C series motors in traction applications. The induction motor, for the same power output, is smaller and lighter in weight and ideally suited for rail based Mass Rapid Transit applications. The motor tractive effort and speed is regulated by Variable Voltage and Variable Frequency control and can be programmed to suit the track profile and operating parameters. Another advantage of 3 phase a.c. drive and VVVF control is that regenerative braking can be introduced by lowering the frequency and the voltage to reverse the power flow and to allow braking to very low speed.

For this corridor, 3 phase a.c. traction drive that are self ventilated, highly reliable, robust construction and back up by slip/ slid control have been recommended.

The AC catenary voltage is stepped down through a transformer and converted to DC voltage through convertor and supply voltage to DC link, which feeds inverter operated with Pulse Width Modulation(PWM) control technology and using insulated Gate Bipolar Transistors(IGBT). Thus 3 phase variable voltage variable frequency output drives the traction motors for propulsion.

Recently advanced IGBT has been developed for inverter units. The advanced IGBT contains an Insulated Gate Bipolar Transistor (IGBT) and gate drive circuit and protection. The advanced IGBT incorporates its own over current protection, short circuit protection, over temperature protection and low power supply detection. The IGBT has internal protection from over current, short circuit, over temperature and low control voltage.

The inverter unit uses optical fiber cable to connect the control unit to the gate interface. This optical fibre cable transmits the gate signals to drive the advanced IGBT via the gate interface. This optical fiber cable provides electrical isolation between the advanced IGBT and the control unit and is impervious to electrical interference. These are recommended for adoption in trains of Pune Metro.

4.8.12 Interior and gang ways

The passenger capacity of a car is maximized in a Metro System by providing longitudinal seats for seating and utilizing the remaining space for standing passenger. Therefore all the equipments are mounted on the under frame for maximum space utilization. The gangways are designed to give a wider comfortable standing space during peak hours along with easy and faster passenger movement especially in case of emergency.

4.8.13 Passenger Doors

For swift evacuation of the passenger in short dwell period, four doors of adequate width, on each side of the coach have been considered. These doors shall be of such dimensions and location that all the passenger inside the train are able to evacuate with in least possible time without conflicting movement. As the alignment passes through elevated section at 10 to 12 meters above ground, automatic door closing mechanism is envisaged from consideration of passenger safety. Passenger doors are controlled electrically by a switch in Driver cab. Electrically controlled door operating mechanism has been preferred over pneumatically operated door to avoid cases of air leakage and sluggish operation of doors.

The door shall be of bi-parting, Sliding Type as in the existing coaches of DMRC.

4.8.14 Air –Conditioning

With heavy passenger loading of 6 persons/m² for standee area and doors being closed from consideration of safety and with windows being sealed type to avoid transmission of noise, the air conditioning of coaches has been considered essential. Each coach shall be provided with two air conditioning units capable of automatically controlling interior temperature throughout the passenger area at 25 °C with 65% RH at all times under varying ambient condition up to full load. For emergency situations such as power failure or both AC failures etc ventilation provision supplied from battery will be made. Provision shall be made to shut off the fresh air intake and re-circulate the internal air of the coach, during an emergency condition, such as fire outside the train causing excessive heat and smoke to be drawn in to the coach.

4.8.15 Cab Layout and Emergency detrainment door

The modern stylish driver panel shall be FRP moulded which give maximum comfort and easy accessibility of different monitoring equipments to the driver along with clear visibility. The driver seat has been provided at the left side of the cabin.

An emergency door for easy detainment of the passengers on the track has been provided at the centre of the front side of each cabin which has an easy operation with one handle type master controller.

4.8.16 Communication

The driving cab of the cars are provided with continuous communication with base Operational Control Center and station control for easy monitoring of the individual train in all sections at all the time.

Public Address and Passenger Information Display System is provided in the car so that passengers are continuously advised of the next stoppage station, final destination station, interchange station, emergency situations if any, and other messages. The rolling stock is provided with Talk Back Units inside the cars, which permit conversation between passengers and the drivers in case of any emergency.

4.8.17 Noise and Vibration

The train passes through heavily populated urban area .The noise and vibration for a metro railway becomes an important criteria from public acceptance view point. The source of noise are (i) rail-wheel interaction (ii) noise generated from equipment like Blower, Compressor, air conditioner, door, Inverter etc. (iii) traction motor in running train .For elimination and reduction of noise following feature are incorporated: -

- Provision of anti drumming floor and noise absorption material
- Low speed compressor, blower and air conditioner
- Mounting of under frame equipments on anti-vibration pad
- Smooth and gradual control of door
- Provision of GRP baffle on the via-duct for elimination of noise transmission
- Provision of sound absorbing material in the supply duct and return grill of air conditioner
- Sealing design to reduce the aspiration of noise through the gap in the sliding doors and piping holes

The lower vibration level has been achieved by provision of bolster less type bogies having secondary air spring.

4.8.18 Passenger Safety Features

(i) ATP/ATO

The rolling stock is provided with Continues Automatic Train Protection and Automatic Train Operation (in future) to ensure absolute safety in the train operation. It is an accepted fact that the 60-70% of accidents take place on

account of human error. Adoption of this system ensures freedom from human error. The on board computerized ATC system compare and verify the continuous data like speed etc .for safest train control.

(ii) Fire

The rolling stock is provided with fire retarding materials having low fire load, low heat release rate, low smoke and toxicity inside the cars. The electric cables used are also normally low smoke zero halogen type which ensures passenger safety in case of fire.

(iii) Emergency door

The rolling stock is provided with emergency evacuation facilities at several vehicles to ensure well-directed evacuation of passengers in case of any emergency including fire in the train.

(iv) Crash worthiness features

The rolling stock is provided with inter car couplers having crashworthiness feature which reduces the severity of injury to the passengers in case of accidents.

(v) Gangways

Broad gangways are provided in between the cars to ensure free passenger movement between cars in case of any emergency.

The salient features of the proposed Rolling Stock are enclosed as **Annexure-I**.

Annexure- I
SALIENT FEATURES OF MRTS ROLLING STOCK

S.No.	Parameter	Details
1	Gauge (Nominal)	1435mm
2	Traction system	
2.1	Voltage	25 KV AC
2.2	Method of current collection	Overhead Current Collection System
3	Train composition	
3.1	4 car :	DTC + MC + MC + DTC
3.2	6 car:	DTC + MC + TC + MC + MC + DTC
4	Coach Body	Stainless Steel
5	Coach Dimensions	
5.1	Height	3.9 m
5.2	Width	2.9 m
5.3	Length over body (approx)	
	- Driving Trailer Car (DTC)	21.64 m
	- Trailer Car (TC)	21.34 m
	- Motor Car (MC)	21.34 m
	<i>Maximum length of coach over couplers/buffers:</i>	22.6 m
5.4	Locked down Panto height (if applicable)	N.A
5.5	Floor height	1100mm
6	Designed - Passenger Loading	4048 mm
6.1	Design of Propulsion equipment	8 Passenger/ m ²
6.2	Design of Mechanical systems	10 Passenger/ m ²
7	Carrying capacity-@ 6 standees/sqm	
7.1	Coach carrying capacity	
	DTC	247 (seating - 43 ; standing - 204)
	TC	270 (seating - 50 ; standing - 220)
	MC	270 (seating - 50 ; standing - 220)
7.2	Train Carrying capacity	
	4 car train	1034 (seating - 186 ; standing - 848)
	6 car train	1574 (seating - 286 ; standing - 1288)
8	Weight (Tonnes)	
8.1	Tare weight (maximum)	
	DTC	39
	TC	39
	MC	39

S.No.	Parameter	Details
8.2	Passenger Weight in tons	@ 0.065 T per passenger
	DTC	16.055
	TC	17.55
	MC	17.55
8.3	Gross weight in tons	
	DTC	55.055
	TC	56.55
	MC	56.55
9	Axle load(T)(@ 8 persons per sqm of standee area)	15.32
		System should be designed for 16T axleload
10	Maximum Train Length (6 car)- Approximate	129 m
11	Speed	
10.1	Maximum Design Speed	95 Kmph
10.2	Maximum Operating Speed	85 Kmph
12	Wheel Profile	UIC 510-2
13	Noise Limits (ISO 3381 and 3058 - 2005)	
13.1	Stationary (Elevated and at grade)	
13.1.1	Internal (cab and saloon)	L_{pAFmax} 65 dB(A)
13.1.2	External (at 7.5 mtr from centre line of track)	L_{pAFmax} 68 dB(A)
13.2	Running at 85 kmph (Elevated and at grade)	
13.2.1	Internal (cab and saloon)	$L_{pAeq,30}$ 72 dB(A)
13.2.2	External (at 7.5 mtr from centre line of track)	L_{pAFmax} 85 dB(A)
13.3	Stationary (Underground)	
13.3.1	Internal (cab and saloon)	L_{pAFmax} 72 dB(A)
14	Traction Motors Ventilation	Self
15	Acceleration on level tangent track	0.82 m/sec ²
16	Deacceleration on level tangent track	1.1 m/sec ² (>1.3 m/sec ² during emergency)
17	Type of Bogie	Fabricated
18	Secondary Suspension springs	Air
19	Brakes	Wheel disc
20	Coupler	Auto

S.No.	Parameter	Details
	Outer end of 2-car Unit (except DT cab front) Outer end of 2-car Unit (except DT cab front)	Automatic coupler with mechanical, electrical & pneumatic coupling
	Between cars of same Unit	Semi-permanent couplers
21	Detrainment Door	Front
22	Type of Doors	Sliding
23	Passenger Seats	Stainless Steel
24	Cooling	
24.1	Transformer	Forced
24.2	CI & SIV	Self/Forced
24.3	TM	Self ventilated
25	Control System	Train based Monitor & Control System (TCMS/TIMS)
26	Traction Motors	3 phase VVVF controlled
27	Temperature Rise Limits	
27.1	Traction Motor	Temperature Index <u>minus</u> 70 deg C
27.2	CI & SIV	10 deg C temperature margin for Junction temperature
27.3	Transformer	IEC specified limit-20 deg C
28	HVAC	Cooling, Heating & Humidifier (As required)
29	PA/PIS including PSSS (CCTV)	Required
30	Passenger Surviellance	Required
31	Battery	Lead Acid Maintenance free
32	Headlight type	LED
33	Gradient (max)	3%
34	Average Cost per car exclusive of taxes and duties at Oct 2008 Price level in Rs Crores.	10

Chapter - 5

Civil Engineering



- 5.1 Geometric Design Norms
- 5.2 Description of Corridors
- 5.3 Description of Route alignment
- 5.4 Rail Levels and Alignment
- 5.5 Platforms
- 5.6 Sequence of Stations
- 5.7 Planning and Design Criteria for Stations
- 5.8 Typical Elevated Station
- 5.9 Typical Underground Station
- 5.10 Passenger Amenities
- 5.11 Traffic Integration
- 5.12 Civil Structures
- 5.13 Construction Methodology
- 5.14 Structural System of Viaduct
- 5.15 Construction Methods
- 5.16 Construction of Stations
- 5.17 Geo-Technical Investigations
- 5.18 Recommendations
- 5.19 Utility Diversion
- 5.20 Land Requirement for Corridors
- 5.21 Land Requirement for Property Development
- 5.22 Summary of Land Requirement
- 5.23 Relocation/Resettlement



CHAPTER 5

CIVIL ENGINEERING

5.1 GEOMETRIC DESIGN NORMS

5.1.1 General

The design parameters related to the Metro system described herewith have been worked out based on a detailed evaluation, experience and internationally accepted practices. Various alternatives were considered for most of these parameters but the best-suited ones have been adopted for the system as a whole.

5.1.2 Horizontal Alignment

As far as possible, the alignment follows the existing roads. This leads to introduction of many horizontal curves. On consideration of maximum allowable cant of 120 mm and cant deficiency of 85 mm on Metro tracks, the safe speed on curves of radii of 400 m or more is 80 km/h. On elevated section use of curves with minimum radius of 200 m, having speed of 55 km/h shall be adopted. There are, however, exceptional situations where due to site constraints; use of sharper curves is unavoidable. Under such situations on this project, curves of 160 m radius (safe speed of 40 km/h) have been adopted. However in underground section desirable minimum radius of curve shall be 250m for ease of working of Tunnel Boring Machine.

For maximum permissible speed on curve with various radii, **Table 5.1** may be referred.

5.1.3 Horizontal Curves

Description	Underground Section	Elevated Section
Desirable Minimum radius	300 m	200 m
Absolute minimum radius	200 m	120 m
Minimum curve radius at stations	1000 m	1000 m
Maximum permissible cant (Ca)	120 mm	120 mm
Maximum cant deficiency (Cd)	85 mm	85 mm

5.1.4 Transition Curves

The existing roads along which the metro is proposed have frequent curves. However, it is necessary to provide transition curves at both ends of the circular curves. Due to change in gradients at various locations in the corridor, it is necessary to provide frequent vertical curves along the alignment. In case of ballast less track, it is desirable that the vertical curves and transition curves of horizontal curves do not overlap. These constraints may lead to reduced lengths of transition curves. The transition curves have certain minimum parameters:

- Length of Transitions of Horizontal curves (m)

Minimum : 0.44 times actual cant or cant deficiency (in mm) whichever is higher.

Desirable : 0.72 times actual cant or cant deficiency, (in mm), whichever is higher.

- Overlap between transition curves and vertical curves not allowed.
- Minimum straight between two Transition curves: either 25 m or Nil.
- Minimum curve length between two transition curves: 25 m

5.1.5 Vertical Alignment and Track Centre

(a) Elevated Sections

The viaducts carrying the tracks will have a vertical clearance of minimum 5.5 m above road level. For meeting this requirement with the 'Box' shaped pre-stressed concrete girders, the rail level will be about 9.8 m above the road level. However, at stations which are located above central median, the rail level will be 12.5 m above the road level with concourse at mezzanine. These levels will, however, vary marginally depending upon where the stations are located.

The track center on the elevated section is kept as 4.1 m uniform throughout the corridor to standardize the superstructure, except at few locations; wherever scissors crossovers are planned; it is kept 4.5m.

(b) Underground sections

Rail level at midsection in tunneling portion shall be kept at least 12.0 m belows the ground level. At stations, the desirable depth of rail below ground level is 12.5 m, so

that station concourse can be located above the platforms.

Track centre in underground sections are follows.

Sections where stations are to be constructed by Cut & cover and running section by TBM to accommodate 12m wide plat PF : 15.05m

Sections where stations are to be constructed By NATM and running section by TBM to Facilitate construction of Stations : 22.00m

Sections where stations as well as running Section as well as stations both are to be constructed cut & cover are to be constructed : 4.5.00m

(c) Gradients

Normally the stations shall be on level stretch. In limited cases, station may be on a grade of 0.1 %. Between stations, generally the grades may not be steeper than 3.0 %. However, where existing road gradients are steeper than 2 %, gradients or for Switch-over Ramps upto 4% (compensated) can be provided in short stretches on the main line.

(d) Vertical Curves

Vertical curves are to be provided when change in gradient exceeds 0.4%. However, it is recommended to provide vertical curves at every change of gradient.

Radius of vertical curves:

- On main line (desirable) : 2500 m
- (Absolute minimum) : 1500 m
- Other Locations : 1500 m
- Minimum length of vertical curve : 20 m

5.1.6 Design Speed

The maximum sectional speed will be 80 km/h. However, the applied cant, and length of transition will be decided in relation to normal speeds at various locations, as determined by simulation studies of alignment, vertical profile and station locations. Computerized train

simulation studies need to be conducted with proposed gradients at the time of detailed design stage. This is with the objective of keeping down the wear on rails on curves to the minimum.

Table 5.1- Cant, Permitted Speed & Minimum Transition Length for Curves

RADIUS(m)	CANT(mm)	MAXIMUM PERMISSIBLE SPEED	MINIMUM DISTANCE BETWEEN ADJACENT TRACKS(mm)	
			UNDER GROUND	ELEVATED AND AT-GRADE
3000	15	80	3500	3650
2800	15	80	3500	3650
2400	20	80	3500	3650
2000	20	80	3500	3650
1600	25	80	3500	3650
1500	30	80	3500	3650
1200	35	80	3500	3650
1000	45	80	3500	3700
800	55	80	3550	3700
600	70	80	3550	3750
500	85	80	3600	3750
450	95	80	3600	3800
400	105	80	3650	3800
350	110	75	3650	3800
300	110	70	3700	3850
200	110	55	3800	3950
150*	110	50	4000	4050
150*	0	30	4000	4050
120*	110	45	4000	4150
120*	0	30	4000	4150

- Notes:**
- (a) The track spacing is without any column/structure between two tracks and is with equal cant for both outer and inner tracks.
 - (b) Track spacing shown is not applicable to stations which should be calculated depending on specific requirement.
 - (c) Figures for any intermediate radius of curvature may be obtained by interpolating between two adjacent radii. For higher radii, values may be extrapolated.

5.1.7 Station Locations

Stations have been located so as to serve major passenger destinations and to enable convenient integration with other modes of transport. However effort has also been made to propose station locations, such that inter station distances are as uniform as possible. The average spacing of stations is kept close to 1.0km.

5.2 DESCRIPTION OF CORRIDORS

Two corridors have been recommended for Pune Metro Rail Project which are as under:

5.2.1 Corridor-1: Pimpri Chinchwad (PCMC) to Swargate.

From dead end (Ch. – 450 m) of PCMC station to dead end of Swargate station (Ch. 16139m), the length of corridor 1 is 16.589 km, out of which 4.661 km is underground and remaining 11.570 km is elevated Including length of Switch Over Ramp(SWR). Total 15 numbers of stations have been planned along this corridor out of which 9 are elevated and 6 are underground stations.

5.2.2 Corridor-2: Vanaz (Kothrud Depot) to Ramwadi.

From dead end (Ch – 684.8 m) of Vanaz station to dead end of Ramwadi station (Ch. 13790m), the length of corridor 2 is 14.665 km. Total 16 number of elevated stations have been planned along this corridor.

5.3 DESCRIPTION OF ALIGNMENT

5.3.1 CORRIDOR - 1

Introduction

Corridor 1 of Pune metro rail project passes across the middle of Pune city and runs in North-South direction. It originate from Pimpri Chinchwad(PCMC) in North and terminates at Swargate in South. It further can be extended southward beyond Swargate. It starts from PCMC and runs on the Eastern side footpath of NH-4 for a initial length of 6.8 km between km (-) 0.450 & km 6.37. Here it further turns Eastward and crosses Mula river between km 6.630 and km 6.78; it further moves forward and after having a right having a right turn it aligns along the median of NH-4 and runs along it up to km 8.530. It leaves NH – 4 at km 8.580; turns align along the centre of a road leading towards Agriculture University. It enters in the premises of Agriculture University at km 10.365 and runs in university area for a length of 959m. It exits university premise at km 11.324. Switch Over Ramp has been planned in university area between km 10.760 and km 11.120. Alignment attains

underground in university area and after exiting from it; it runs almost under Shivaji Road prior to PMC office. In PMC office area; alignment is in the East of the Shivaji road; where PMC station has been planned. It crosses Mutha River in underground position at km 13.040. Henceforth alignment runs under the heavily habitated area of Budhwar peth & Mandai and reaches Swargate.

Overall length of alignment is km 16.589 from dead end to dead end .Out of which 5.019 km is underground and remaining 11.570 km including length of SOR is elevated 15 stations have been planned along the corridor out of these 6 are underground and 9 are elevated. Depot has been planned in the premise of Agriculture University; an area of 11.51 Ha has been identified along railway lines.

5.3.2 Reference Line

Centre line of PCMC station has been taken as '0' for reckoning of chainage on Corridor 1. Chainage increases from PCMC station towards Swargate station. Line from PCMC station to Swargate station has been named as "Up line" and from Swargate station to PCMC station is named as "Down line".

5.3.3 Terminal stations

PCMC Terminal Station

The terminal station of Corridor 1 is Pimpri Chinchwad (PCMC) station, with its center line at Ch. 0.00 m. This station is elevated. At the end of this station, the train reversal facilities have been proposed by providing cross-over at the rear end. The dead end of Corridor 1 is at Ch (-) 450 m. Reversal length can be used for night stabling of rakes.

Swargate Terminal Station

The terminal station at other end of Corridor 1 is Swargate station with its center line at Ch.15/689 km. This station is underground. At the end of this station, the train reversal facilities have been proposed by providing cross-overs at the rear end. The dead end of Corridor 1 is at Ch. 16/139 km. Provision for further extension of Metro lines has been kept in view at the dead end. Similar to starting terminal night stabling of rakes on reversal length of tracks has been planned on this terminal as well.

5.3.4 Route Alignment

To describe the alignment property it has been divided in three sections as follows:

- i. Elevated section (km (-) 0.450 to km 10/760)
- ii. Switch Over Ramp (km10/760 to km 11/120)
- iii. Underground section (km 11/120 to 16/139)

5.3.5 Elevated section (km (-) 0.450 to km 10/760)

In the beginning from km (-) 0.450 to km 6/630 alignment has been kept on the left side on median of service road due to a number of underpasses and wider row of existing road; which required wider concourse at stations and substantial increase in the cost of stations. Hereafter, it crosses Mula River km 6/700 and runs in the downstream of existing Road Bridge at a distance of about 50 m. It aligns along the central verge of the road at km 7/020, runs along it up to km 8/532. Henceforth, it turns right through a curve of 2000 m; crosses railway tracks and aligns along an existing 6 m wide road; from km 9/160 to km 10/150. In this about 1 km long stretch it is proposed to widen the road up to four lane with central median to accommodate Metro system. Alignment enters Agriculture University premises at km 10/365. This section ends in the Agriculture University area at km 10/760.

In this section 22 Nos. of curves have been provided. Out of these curves, sharpest one is 200 m, which has occurred at two locations; whereas flattest radius is 10,000 m occurring at 4 locations. Length of straights between two curves in this section is greater than 25 m at all locations and 19% alignment is curved.

Vertical alignment has been designed keeping in view 5.5 m clearance from road surface to bottom of the girder. It has been increased by about 3.5 m at station locations to accommodate concourse of stations. Ground profile in this section varies from highest level at PCMC, i.e. 576 m from mean sea level (MSL) to 552 m from MSL at Range Hill. Existing ground profile generally falling or raising at the rate of 2% gradient. Change of grade takes place at 34 locations. Steepest grade is 3.5% which has been provided to bring alignment from elevation position to underground position. Flattest grade is level; which has been provided at stations. Longest length at same grade is between km (-) 0.450 to km 0.190 m, which is 640 m long at 0% gradient at PCMC terminal station.

5.3.6 Switch Over Ramp (km 10/760 to 11/120)

Switch Over Ramp (SOR) or at Grade Ramp is required to switch over alignment from elevated position to underground position or vice versa. SOR has been planned between km 10/760 to km 11/120 in Agriculture University area; just after Range hill station. Depot for this line has been planned on the east of SOR adjacent to existing Railway line. Location of switch over ramp has been decided keeping in view the availability of land; without creating hindrance to traffic flow on roads. Therefore, it has been located on off road position. About 10.50 m wide strip of land shall be required permanently. It has been planned with 3.5% gradient to minimize the length of ramp (Ref. Fig 5.1)

5.3.7 Underground Section (Km 11/120 TO 16/139)

Underground section can be further divided in to two sections:

- (a) Underground section by Cut & Cover Method.
- (b) Underground section by tunnel Boring Machine (TBM).

5.3.8 Underground section by Cut & Cover Method

Alignment attains underground position at km 11/120 at the end of Switch Over Ramp. It has been planned to construct initial 0.905km length of alignment by Cut & Cover Method from km 11/120 to km 12/030; as this stretch is along the existing road and traffic can be diverted to other roads during construction; as indicated by PMC officials during a meeting on 06/12/2008.

Four horizontal curves having radius 160 m to 1000 m has been provided in this stretch. 160 m radius curves occur at two locations and have been provided to align the alignment along the middle of road, while it comes out from Agriculture University Area. 302 m length in this stretch is on 160 m radius curves; tunnel Boring Machine cannot negotiate curves sharper than 200 m. It is also a reason to construct this section by Cut & Cover Method. Moreover, construction cost of underground section by Cut & Cover Method is lesser than the TBM.

3.5% gradient from preceding section continues to run in this section up to km 11/300, till alignment attains full depth desired for underground section, i.e. about 12.00 m. Henceforth, a down gradient of 0.4% has been provided up to approach of Shivaji Nagar station, which has been planned at level gradient. On exit from Shivaji Nagar station further a down gradient of 0.526% has been planned to increase depth at ASI station; to bring gradient originating from end of ASI station within the stipulated limit.

5.3.9 Underground section by Tunnel Boring Machine (TBM)

Alignment beyond Shivaji Nagar Chowk onward deviates from its on-road position and runs straight as far as possible under heavily built up area to keep underground length as much minimum as possible. Police station land at Shivaji Chowk has been earmarked for Tunnel Boring Machine lowering. Alignment further proceeds towards Swargate in underground position parallel to Shivaji Road, crosses Jangali Maharaj Road, at km 12/345. Another corridor from Vanaz to Ramawadi crosses this corridor in elevated position at this junction. ASI station has been planned just after crossing Jangali Maharaj Road. It further proceeds and enters PMC area. PMC station has been proposed under existing PMC office. It crosses Mutha River at km 13/040. A reverse curve of 500m and 450 m radii respectively has been introduced to avoid its entrance under the Shaniwarwada. It aligns parallel to the Shivaji Road; cuts across it at km 14/910; runs in the west to Shivaji Road up to km 15/360. It

further crosses it and again becomes parallel to Shivaji Road on the eastern side after having a turn through a 500 m radius curve and runs straight up to end of this section.

Construction in this section had been proposed by TBM and therefore no curve of less than 200 m radius is planned. Total number of curves provided is 6, out of which 2 Nos. are of 200 m radius. Maximum radius of curve is 1000 m, which has been provided at one location. Efforts have been made to maintain radius as larger as possible to facilitate smooth working of TBM as well as smooth riding on trains.

Vertical alignment has been designed keeping adequate cushion (about 6 m) over the tunnel under the bed level of Mutha River. This has resulted in deepening of PMC station as well as ASI station. Depth at PMC station below the existing road level is 23.00 m.

Change of grades takes place at 12 locations. Steepest gradient provided in the section is 3.679%, which has been provided on exit from ASI station to lower PMC station adequately, so that alignment could pass below the bed level of River Mutha River. Longest level at same grade is on level gradient that has been provided at Swargate station.

Five stations have been planning in this stretch and out of these stations four stations, except Swargate station, shall be constructed by New Austrian Tunneling Method (NATM). Open spaces, dilapidated buildings have been identified to locate shafts to facilitate construction of stations by NATM. These locations have been marked in the alignment plans.

5.3.10 Horizontal Curves

While designing horizontal alignment; efforts have been made to keep alignment straight as far as possible. However it is not possible in case of elevated sections; where alignment has to follow central median of existing roads. Geometrics of existing roads at certain locations is too kinky that metro alignment cannot follow the same. Alignment at these locations has deviated from on road position to off road position to keep metro alignment geometry within stipulated norms.

Total 32 number of curve have been provided in this corridor. Over all 23% alignment is on curves. Sharpest curve is 160m; whereas flattest is 10000m. Abstract and details of horizontal curves have been put on Tables 5.2 and Table 5.3 respectively.

Table 5.2- Abstract of Horizontal Curves

S.No	Radius	Nos. of occurrences	Curve Length	% w.r.t. Total Curve Length
1.	160	2	301.774	7.89
2.	200	4	628.941	16.45
3.	275	1	136.597	3.57

S.No	Radius	Nos. of occurrences	Curve Length	% w.r.t. Total Curve Length
4.	300	6	758.942	19.85
5.	450	1	240.473	6.29
6.	500	5	600.157	15.70
7.	525	1	135.381	3.54
8.	1000	4	561.576	14.69
9.	5000	4	296.699	7.76
10.	10000	4	162.939	4.26
	Total	32	3823.479	100

Table 5.3- Statement of Horizontal Curves

Curve No	Direction	Radius	Deflection Angle			Transiti on Length		Tangent Length	Curve Length	Total Curve Length
			D	M	S					
1	Left	-10000	0	5	12	10	10	12.571	5.142	25.142
2	Right	10000	0	8	1	10	10	16.661	13.323	33.323
3	Left	-10000	0	17	40	10	10	30.691	41.381	61.381
4	Right	275	15	57	32	60	60	68.613	16.597	136.597
5	Right	5000	0	13	23	10	10	14.728	9.457	29.457
6	Left	-10000	0	11	23	10	10	21.547	23.093	43.093
7	Right	525	10	24	34	40	40	67.833	55.381	135.381
8	Left	-300	11	47	7	50	50	55.993	11.707	111.707
9	Right	500	6	44	49	40	40	49.48	18.879	98.879
10	Right	300	11	44	39	50	50	55.884	11.492	111.492
11	Left	-300	13	5	49	50	50	59.472	18.575	118.575
12	Left	-300	15	4	27	50	50	64.733	28.928	128.928
13	Right	5000	0	57	17	10	10	46.653	73.304	93.304
14	Right	200	27	45	47	50	50	74.542	46.911	146.911
15	Left	-200	19	56	40	50	50	60.244	19.619	119.619
16	Right	300	17	28	46	50	50	71.167	41.522	141.522
17	Left	-500	8	16	37	40	40	56.187	32.23	112.23
18	Right	1000	2	5	54	25	25	30.814	11.623	61.623
19	Right	5000	0	35	28	10	10	30.798	41.595	61.595
20	Left	-5000	1	10	22	10	10	56.173	92.343	112.343
21	Left	-1000	2	30	56	35	35	39.456	8.903	78.903
22	Right	300	18	28	18	50	50	73.833	46.718	146.718
23	Left	-160	38	12	31	60	60	85.708	46.698	166.698
24	Right	160	26	53	4	60	60	68.431	15.076	135.076

Curve No	Direction	Radius	Deflection Angle			Transition		Tangent Length	Curve Length	Total Curve
			8	21	25	40	40			
25	Left	-500	8	21	25	40	40	56.538	32.929	112.929
26	Right	1000	15	9	26	25	25	145.552	239.543	289.543
27	Left	-200	47	19	30	50	50	112.853	115.195	215.195
28	Right	200	27	51	1	50	50	74.704	47.216	147.216
29	Left	-500	11	10	2	45	45	71.396	52.453	142.453
30	Right	450	24	53	18	45	45	121.842	150.473	240.473
31	Right	1000	6	6	9	25	25	65.805	81.507	131.507
32	Right	500	10	44	0	40	40	66.982	53.666	133.666

5.3.11 Gradients

While designing vertical alignment; efforts have been made to keep grades as flatter as possible. However facilitate proper drainage minimum gradient adopted is 0.25% except stations; where level gradient has been provided. Majority of grades are less than 1%. Flattest gradient is level, which has been provided on stations. Steeper gradients have introduced wherever they are essentially required; such as for SOR etc. Total at 49 locations change of grade takes place. Abstract of gradients and details of gradient have been put in **Table 5.4& 5.5** respectively.

Table 5.4-Abstract of Gradients

S. N.	Description	No of Occurrences	Length (m)	% w.r.t. Total Length
1	0 - 1%	31	10200.1	61.48
2	>1 - 2 %	10	3406.5	20.54
3	>2 - 3%	6	2120.0	12.78
4	>3 - 3.7%	2	862.0	5.20
TOTAL		49	16588.6	100

Table 5.5- Statement of Gradients

S. No.	Chainage		Length	Rail Level		Gradient(%)	Remarks
	From	To		From	To		
1	-450.000	190.000	640.000	588.250	588.250	0.000	Level
2	190.000	500.000	310.000	588.250	580.000	-2.661	Fall
3	500.000	840.000	340.000	580.000	583.300	0.971	Rise
4	840.000	1280.000	440.000	583.300	573.900	-2.136	Fall
5	1280.000	1620.000	340.000	573.900	575.800	0.559	Rise
6	1620.000	1900.000	280.000	575.800	575.800	0.000	Level
7	1900.000	2370.000	470.000	575.800	568.800	-1.489	Fall

S. No.	Chainage		Length	Rail Level		Gradient(%)	Remarks
	From	To		From	To		
8	2370.000	2840.000	470.000	568.800	570.400	0.340	Rise
9	2840.000	3100.000	260.000	570.400	570.400	0.000	Level
10	3100.000	3340.000	240.000	570.400	571.600	0.500	Rise
11	3340.000	3620.000	280.000	571.600	574.200	0.929	Rise
12	3620.000	3860.000	240.000	574.200	574.200	0.000	Level
13	3860.000	4300.000	440.000	574.200	567.600	-1.500	Fall
14	4300.000	4600.000	300.000	567.600	565.200	-0.800	Fall
15	4600.000	4730.000	130.000	565.200	567.000	1.385	Rise
16	4730.000	5115.000	385.000	567.000	567.000	0.000	Level
17	5115.000	5470.000	355.000	567.000	564.500	-0.704	Fall
18	5470.000	5900.000	430.000	564.500	568.500	0.930	Rise
19	5900.000	6140.000	240.000	568.500	568.500	0.000	Level
20	6140.000	6520.000	380.000	568.500	561.400	-1.868	Fall
21	6520.000	6920.000	400.000	561.400	563.500	0.525	Rise
22	6920.000	7110.000	190.000	563.500	568.600	2.684	Rise
23	7110.000	7320.000	210.000	568.600	568.600	0.000	Level
24	7320.000	7520.000	200.000	568.600	568.400	-0.100	Fall
25	7520.000	7831.500	311.500	568.400	572.700	1.380	Rise
26	7831.500	8100.000	268.500	572.700	572.700	0.000	Level
27	8100.000	8550.000	450.000	572.700	574.300	0.356	Rise
28	8550.000	9020.000	470.000	574.300	567.800	-1.383	Fall
29	9020.000	9380.000	360.000	567.800	569.800	0.556	Rise
30	9380.000	9680.000	300.000	569.800	565.600	-1.400	Fall
31	9680.000	9980.000	300.000	565.600	565.200	-0.133	Fall
32	9980.000	10430.000	450.000	565.200	565.200	0.000	Level
33	10430.000	10650.000	220.000	565.200	561.000	-1.909	Fall
34	10650.000	11300.000	650.000	561.000	538.250	-3.500	Fall
35	11300.000	11666.000	366.000	538.250	536.850	-0.383	Fall
36	11666.000	11920.000	254.000	536.850	536.850	0.000	Level
37	11920.000	12310.000	390.000	536.850	534.800	-0.526	Fall
38	12310.000	12535.000	225.000	534.800	534.800	0.000	Level
39	12535.000	12747.000	212.000	534.800	527.000	-3.679	Fall
40	12747.000	12980.000	233.000	527.000	527.000	0.000	Level
41	12980.000	13490.000	510.000	527.000	537.800	2.118	Rise
42	13490.000	13740.000	250.000	537.800	537.500	-0.120	Fall
43	13740.000	13990.000	250.000	537.500	537.500	0.000	Level
44	13990.000	14340.000	350.000	537.500	547.900	2.971	Rise
45	14340.000	14620.000	280.000	547.900	544.300	-1.286	Fall
46	14620.000	14860.000	240.000	544.300	544.300	0.000	Level

S. No.	Chainage		Length	Rail Level		Gradient(%)	Remarks
	From	To		From	To		
47	14860.000	15180.000	320.000	544.300	553.900	3.000	Rise
48	15180.000	15585.000	405.000	553.900	561.500	1.877	Rise
49	15585.000	16138.595	553.595	561.500	561.500	0.000	Level

5.3.12 Break up of Alignment Length for Corridor 1

Breakup of alignment length for Corridor 1 is given in **Table 5.6**:

Table 5.6- Breakup of alignment length

S. N.	Description	Chainage(m)		Length (m)
		From	To	
1.	Elevated	(-) 450.00	10760.00	11210.00
2.	Switch Over Ramp	10760.00	11120.00	360.00
3.	Underground by cut & cover	11120.00	12025.00	905.00
4.	Underground by TBM	12025.00	16138.595	4113.595
Alignment length (Total)				16588.595

5.3.13 CORRIDOR - 2

Reference Line

Dead End of Vanaz station has been taken as '0' for reckoning of chainage on Corridor 2. Chainage increases from Vanaz station towards Ramwadi station. Line from Vanaz station to Ramwadi station has been named as "Up line" and from Vanaz to Ramwadi is named as "Down line".

Terminal Stations

Vanaz Station

First terminal station on this corridor is Vanaz, which has been provided at km 0/00. Alignment on rear end of station has been extended about 685 m; to plan depot entry, which has been planned on Katchra depot land as well as to provide reversal facilities. As depot has been planned very close to this station, no stabling is required at this station.

Ramwadi Station

Another terminal station has been provided on the Eastern end of this corridor at km 13/790. Lines have been extended for 450 m from the centre line of the station to provide train reversal facilities as well as night stabling of trains to start early morning services.

Inter-change Stations

While deciding location of stations, efforts have been made to have their integration with other modes of transport, such as buses, railways, etc. The following stations shall have inter-changeability with existing Railway network and corridor-1 of proposed Metro system.

Table No. 5.7- Inter-change Stations

S. No.	Station	Inter-change with
01	Civil court	PMC Station on corridor-1 of Pune Metro.
02	Pune Railway Station	Pune Railway Station of Indian Railway.

5.3.14 Description of Alignment

Introduction

This corridor cuts across Pune city in the east-west direction. It starts from Kothrud in the west and terminates at Ramwadi in the east. Starting point of this corridor is near Katchra depot, where the depot for this corridor has been planned. Initial 3.2 km length is along Paud Road, then it runs along Karve Road, crosses Garware College Road. From there on the alignment turns right and runs along left bank of Mutha river upto PMC office where it will be integrated with Corridor -1. From PMC the alignment enters in the river bed area and then takes left turn to cut across a corner affecting some of the encroachments to enter in the Godown area where Civil Court Metro Station is located.

There after it turns right to join earlier planned alignment at Chainage 6800 and aligns along Ambedkar Wellesly Road and runs along it up to Vallabh Bhai Patel Chowk. Henceforth, it goes along H.H. Prince Agha Khan Road, till it reaches Pune Railway Station. Here it deviates from on-road position to off-road position, crosses Railway tracks, aligns along central median of Bund Garden Road and runs along it up to Mahatma Gandhi Udyan (Bund Garden), cuts across the Bund Garden, crosses Mutha River and after having a left hand turn, it aligns along the Southern footpath of Nagar Road. Thereafter it runs along till the end.

Whole alignment has been planned as elevated and most of its length is along the median/footpath of the road. Dead end to dead end length of corridor is 14.665 km. Total 16 stations have been planned along the corridor and all of them are elevated. Depot for this corridor has been planned at Kothrud Katchra depot land.

5.3.15 Horizontal and Vertical Alignment

From km (-) 0/685 to km 2/600 (along Paud Road)

This corridor starts from Kothrud near Katchra depot and runs along Paud Road up to km 2/600. Geometry of the road is kinky. Alignment runs along the central median of the road up to km 2/100. Here it deviates from central median position to negotiate a flyover constructed on Paud Naka. It has been placed on the northern side of the flyover; as soon as flyover ends, alignment again takes central verge position. Right of way (ROW) of Paud Road is more than 20 m, so it is envisaged that there shall be no land acquisition required for running section except the station locations. Alignment along Paud Naka Flyover has been shown in **Fig. 4.2**.

As alignment in this section is along the central median of the road, it has to follow existing road geometrics. Total 11 curves have been provided, out of which three are 160 m radius, which is minimum required for Metro system. Largest radius in this section is 2000 m, which has been used at one location between km 1/505 and 1/807.

In the beginning, vertical profile of existing road is on more than 4% slope. Metro system cannot negotiate such a steep gradient. So the gradient provided between km (-)0/440 to (-) 0/120 has been limited to 3.7%; because of it elevation difference required between road level to rail level, i.e. 9.8 m could not be achieved between km (-)0/410 to km (-)0/250. In this length, to maintain 5.5 m clearance under the bottom of the girder of Metro system the road lowering shall be required. Change of gradient takes place in this section at 12 locations. Steepest gradient provided in this section is 3.7% and flattest is level, which has been provided at station locations.

Three stations - Vanaz, Anand Nagar, and Ideal Colony, at km 0/00, km 0/995 and km 1/900 respectively, have been provided in this section. As described earlier, gradient of existing road is more than 4%, Vanaz station also falls on the same stretch of road. As Vanaz station has been planned on level gradient, it has resulted in the height of station at one end at 12.2 m from the road level, whereas it is 16.7 m at the other end. However, the height at Anand Nagar station is uniform at about 12.8 m and the height of Ideal Colony is also uniform at about 13 m.

5.3.16 Alignment from km 2/600 to km 4/200 (along Karve Road)

Similar to the previous section, alignment in this section also is on the central median of the road. Available ROW of this road varies from 25 m to 40 m. Therefore, no land acquisition is envisaged for running section except stations. As road geometry in this section is smooth. Minimum radius provided is 800 m and largest is 2000 m. Total five curves have been provided, out of which three curves have more than 2000 m radius. Existing road at

beginning of the section is falling with about 2% gradient. A falling gradient of 1.77% provide in the previous section at km 2/340 continues to run in this section up to km 2/708. Steepest gradient provided in this section is 2.74% which has been provided from km 3/060 to 3/400 for a length of 340 m.

Two stations – Nal Stop and Garware College, have been provided at km 2/875 and km 3/880 respectively. Existing road profile at Nal Stop station location is at about 2% gradient. However, the station has been planned on level gradient. Height of this station from road level varies from 12.25 m to 15.25 m from one end to the other. Height of Garware College station varies from 11.9 m to 14.6 m from the road level.

5.3.17 Alignment from Garware College to Civil Court (Chainage 3878.24 to Chainage 6568.4)

From Garware College the alignment turns right and runs along left bank of Mutha river upto PMC office where it will be integrated with Corridor -1. From PMC the alignment enters in the river bed area and then takes left turn to cut across a corner affecting some of the encroachments to enter in the Godown area where Civil Court Metro Station is located.

Earlier there were two stations namely Deccan and ASI between Garware College and Civil Court. However now due to realignment of this stretch along Mutha River three stations have been proposed namely Deccan Bus stop, Sambhaji Garden, and PMC. Traffic projections have however been taken as earlier with two stations. But the costing etc has been done with one additional station.

5.3.18 Alignment from km 6568 to km to km 8800 (along Ambedkar Wellesly Road and H.H. Prince Aga Khan Road)

Alignment enters Ambedkar Wellesly Road after having a right hand turn through 122m radius curve. Alignment proceeds further and after crossing Nyayamurti Ranade Path at km 6/900 it runs south of the bridge across the Mutha river. After that, it again aligns along the central median of Ambedkar Wellesly Road and runs along it up to Vallabh Bhai Patel Chowk. Hereafter, it turn left through a 160 m radius curve and aligns along H.H. Prince Agha Khan Road and runs along till Pune Railway Station. Alignment in this section runs through the roads having kinky geometry, so the minimum radius of 160 m has been used at three locations and 200 m at one location. Largest radius of 3000 m has been used at two places.

Vertical profile of the existing road in this section is not much undulating, so the steepest gradient used in this section is 1.46% which has been provided between km 6/730 and km 7/140 for a length of 410 m. This also the longest gradient used in this section. All stations have been planned on level gradient.

Three stations – Mangalwar Peth, Sasson and Pune Railway Station, have been planned in this section at km 7/671, km 8/207 and km 8/584 respectively. Average height from road level at Mangalwar Peth station is 12.5 m, at Sasson it is 12.8 m and at Pune Railway Station it is 13.0 m.

5.3.19 Alignment from km 8/800 to km 10/730 (along Bund Garden Road) Crossing of Railway Yard at Pune Railway Station

As soon as alignment comes out of the proposed Pune Metro Station, it turns left through a 160 m radius curve, crosses Pune railway yard between km 8/960 and km 9/017, passes through a vacant land in the north of railway yard and aligns along Bund Garden Road after having a right hand turn between km 9/046 and km 9/195 (Refer Fig. 5.5).

Alignment runs along central median of Bund Garden Road up to km 10/525. Hereafter, it enters Mahatma Gandhi Udyan, crosses Solapur Road at km 10/710 and approaches the southern bank of Mutha river.

Nine horizontal curves have been introduced in this section with radius varying from 160 m to 5000 m. Minimum radius of 160 m has been used at three locations, whereas the largest radius of 5000 m has been used at one location.

On existing from Pune Metro Station a down gradient of 1.84% has been provided to reduce height of piers and it is further raised by 1.5% gradient to cross railway yard. Crossing of railway yard has been planned at about 10 m from existing ground level. Profile of Bund Garden Road is continuously falling at an average gradient of 1.5% towards Mutha river. Therefore, a gradient of 1.65% has been provided to minimize the height of piers immediately after the Ruby Clinic Metro Station. Change of grade in this section takes place at seven locations, steepest gradient is 1.8%.

Only two stations have been planned in this section. First is Rub Clinic Station at km 9/380 and the other is Bund Garden Station at km 10/431. Height from the road level at Ruby Clinic Station is 13 m and it is 13.25 m at Bund Garden Station.

5.3.20 Alignment from km 10/730 to km 14/240 (along Nagar Road)

After crossing Solapur Road, the alignment crosses Mutha river at km 10/900 in the downstream of Yerawada Bridge; aligns along the southern footpath of Nagar Road after having a turn through a reverse curve of 160 m radii. It runs along up to km 12/900. Hereafter, it is along the central median of Nagar Road till the end of this section.

Ten horizontal curves with varying radius of 200 m to 1000 m have been provided in this section, out of which four curves are of 600 m radius, followed by three of 300 m curves and one curve each is of 450 m, 300m and 200 m.

Change of grade takes place at 10 locations, with steepest gradient of 2.22% which has been provided between km 12/260 and km 12/575 for 315 m. All the stations have been planned on level gradients.

Three stations – Yarwada, Kalyani Nagar and Ramwadi, have been planned in this section at km 11/292, km 12/660 and 13/790 respectively. Height from the road level at Yerawada Station is 13.3 m, at Kalyani Nagar it is 12.8 m and it will be about 13 m at Ramwadi.

5.3.21 Horizontal Curves

While designing horizontal alignment; efforts have been made to keep alignment straight as far as possible. However it is not possible in case of elevated sections; where alignment has to follow central median of existing roads. Geometrics of existing roads at certain location is too kinky that metro alignment cannot negotiate the same. Alignment at these locations has deviated from on road position to off road position to keep metro alignment geometry within stipulated norms. These locations have been described in detail in alignment description.

Total 46 number of curve have been provided in this corridor. Over all 48.73% alignment is on curves. Sharpest curve is 160m; whereas flattest is 10000m. Abstract and details of horizontal curves have been put on **Tables 5.8** and **Table 5.9** respectively.

Table 5.8- Abstract of Horizontal Curves

S. No	Upto Radius	Nos. of occurrences	Curve Length	% w.r.t. Total Curve Length
1.	200	11	885.554	25.8
2.	300	8	715.893	20.9
3.	800	12	900.557	26.3
4.	1500	6	810.666	23.6
5.	5000	6	115.479	3.4
	Total	46	3428.149	100.0

Table 5.9- Statement of Horizontal Curves

Curve No.	Hand of Arc	Radius (m)	Arc Length (m)	Transition Length (m)		Included Angle D M S	Tangent (m)	Staright Length (m)
				L1	L2			
								162.495
1	Right	800	78.893	40	30.878	05 39 01.085	39.479	0
2	Left	302.1	33.03	81.767	75	06 15 51.988	16.532	366.65
3	Left	202.1	30.623	50	50	08 40 54.184	15.341	0
4	Right	222.1	30.211	50	50	07 47 37.253	15.129	35.346
5	Left	162.1	26.09	75	64.239	09 13 18.484	13.073	0
6	Right	162.1	47.846	64.239	60	16 54 42.003	24.098	0
7	Left	1002.1	171.886	25	25	09 49 39.684	86.154	72.904
8	Right	2002.1	331.536	20	47.7	09 29 16.222	166.148	53.379
9	Right	252.1	172.285	47.7	47.7	39 09 20.916	89.659	396.805
10	Left	162.1	151.887	60	60	53 41 09.092	82.035	93.384
11	Right	1137.1	25.248	25	24.847	01 16 19.833	12.624	0
12	Left	802.1	34.311	35.225	35	02 27 03.381	17.158	226.826
13	Left	3052.1	26.565	15	15	00 29 55.275	13.282	212.335
14	Right	5002.1	260.11	15	15	02 58 45.789	130.084	36.612
15	Left	2002.1	47.326	20	20	01 21 15.715	23.664	307.953
16	Right	802.1	33.913	40	40	02 25 20.956	16.959	215.801
17	Left	302.1	141.135	55	55	26 46 02.828	71.88	151.128
18	Right	1502.1	263.967	25	25	10 04 07.301	132.324	268.081
19	Right	302.1	130.141	55	55	24 40 56.580	66.096	204.412
20	Left	502.1	70.296	50	50	08 01 17.920	35.206	278.603
21	Left	252.1	152.056	55	55	34 33 30.549	78.42	196.024
22	Right	122.1	98.232	55	55	46 05 45.129	51.949	286.374
23	Left	162.1	102.933	50	50	36 22 57.582	53.269	0
24	Right	162.1	103.857	50	50	36 42 33.108	53.781	309.221
25	Right	252.1	28.061	60	60	06 22 39.228	14.045	0
26	Left	602.1	163.798	60	45	15 35 13.309	82.408	266.164
27	Left	122.1	36.899	50	50	17 18 53.498	18.591	31.575
28	Left	1217.1	25.138	20	20	01 11 00.209	12.569	23.668
29	Right	762.1	25.379	30	30	01 54 28.965	12.691	32.151
30	Left	5002.1	111.946	15	15	01 16 56.158	55.975	93.604
31	Left	802.1	171.539	35	35	12 15 12.190	86.098	408.99
32	Left	5002.1	37.183	15	15	00 25 33.277	18.592	207.162
33	Left	162.1	64.997	50	50	22 58 25.988	32.941	157.065
34	Right	162.1	185.295	60	60	65 29 38.891	104.254	415.229
35	Left	437.1	193.95	50	50	25 25 23.898	98.598	41.099

36	Left	867.1	25.306	30	30	01 40 19.646	12.654	102.779
37	Left	612.1	30.441	35	35	02 50 57.956	15.224	0
38	Right	602.1	34.554	35	35	03 17 17.359	17.282	13.074
39	Right	802.1	33.377	30	30	02 23 03.133	16.691	78.587
40	Right	452.1	30.106	45	45	03 48 55.413	15.058	18.205
41	Right	302.1	28.974	50	50	05 29 42.427	14.498	362.445
42	Right	1252.1	26.072	20	20	01 11 35.020	13.037	510.439
43	Left	202.1	36.895	50	50	10 27 35.355	18.499	610.513

5.3.22 Gradients

While designing vertical alignment; efforts have been made to keep grades as flatter as possible. However it is not possible in the stretches of corridor where ever profile of existing road has steep gradients. Stations have been planned on level gradient. Majority of grades are less than 1%. Flattest gradient is level, which has been provided on stations. Steeper gradients have introduced wherever they are absolutely required. Total at 48 locations change of grade takes place. Abstract of gradients and details of gradient have been put in **Table 5.10& 5.11** respectively.

Table 5.10 -Abstract of Gradients

S. N.	Description	No of Occurrences	Length (m)	% w.r.t. Total Length
1	0 - 1%	31	9380.897	62.86
2	>1 - 2 %	13	4104.564	27.30
3	>2 - 3%	4	1149.000	7.70
4	>3 - 3.7%	1	320.000	2.14
TOTAL		49	14954.461	100

Table 5.11- Statement of Gradients

S. No.	Chainage		Length	Rail Level		Gradient (%)	Remarks
	From	To		From	To		
1	-684.79	-440	244.79	610.7	610.7	0%	Level
2	-440	-120	320	610.7	598.95	-3.672	Fall
3	-120	120	240	598.95	598.95	0	Level
4	120	334	214	598.95	593.6	-2.5	Fall
5	334	566.436	232.436	593.6	591.5	-0.903	Fall
6	566.436	870	303.564	591.5	595	1.153	Rise
7	870	1140	270	595	595	0	Level

8	1140	1420	280	595	588.2	-2.429	Fall
9	1420	1720	300	588.2	588.3	0.033	Rise
10	1720	2030	310	588.3	588.3	0	Level
11	2030	2340	310	588.3	583	-1.71	Fall
12	2340	2708	368	583	576.5	-1.766	Fall
13	2708	3060	352	576.5	576.5	0	Level
14	3060	3400	340	576.5	567.2	-2.735	Fall
15	3400	3750	350	567.2	567	-0.057	Fall
16	3750	4033.6	284	567	567	0	Level
17	4033.6	4460	426.404	567	558.7	-1.947%	Fall
18	4460	4785	325	558.7	558.7	0.000%	Level
19	4785	5100	315	558.7	561.1	0.762%	Rise
20	5100	5390	290	561.1	561.1	0.000%	Level
21	5390	5660	270	561.1	556.9	-1.556%	Fall
22	5660	5930	270	556.9	561.5	1.704%	Rise
23	5930	6150	220	561.5	561.5	0.000%	Level
24	6150	6350	200	561.5	565.5	2.000%	Rise
25	6350	6740	390	565.5	565.5	0.000%	Level
26	6740	7080	340	565.5	559.7	-1.706%	Fall
27	7080	7460	380	559.7	564.5	1.263%	Rise
28	7460	7852.81	392.815	564.5	564.5	0.000%	Level
29	7780	8040	260	564.5	566.5	0.769	Rise
30	8040	8320	280	566.5	566.5	0	Level
31	8320	8495	175	566.5	568	0.857	Rise
32	8495	8740	245	568	568	0	Level
33	8740	8930	190	568	564.5	-1.842	Fall
34	8930	9165	235	564.5	568	1.489	Rise
35	9165	9485	320	568	568	0	Level
36	9485	9890	405	568	561.3	-1.654	Fall
37	9890	10295	405	561.3	561.6	0.074	Rise
38	10295	10582.5	287.5	561.6	561.6	0	Level
39	10582.5	10800	217.5	561.6	558.6	-1.379	Fall
40	10800	11120	320	558.6	560	0.437	Rise
41	11120	11460	340	560	560	0	Level
42	11460	11875	415	560	558.8	-0.289	Fall
43	11875	12260	385	558.8	561	0.571	Rise

44	12260	12575	315	561	568	2.222	Rise
45	12575	12780	205	568	568	0	Level
46	12780	13020	240	568	569.8	0.75	Rise
47	13020	13300	280	569.8	571.2	0.5	Rise
48	13300	13560	260	571.2	570.3	-0.346	Fall
49	13560	14239.7	679.671	570.3	570.3	0	Level

5.4 RAILLEVELS AND ALIGNMENT

In underground sections, the rail levels are generally about 14 m below the ground level governed by a ground clearance of 2 m. and a station box of about 14 m depth. In the elevated section, rail level is generally about 12.5 m above ground in order to maintain a clearance of 5.50 m between the road and the station structure. In order to keep the land acquisition to minimum, alignment is planned generally in middle of the road (especially at stations in underground section) and a two-level station design has been proposed in both elevated and underground sections. Entry/exit structures to the proposed stations and traffic integration areas have been planned in the open space available.

5.5 PLATFORMS

All the underground stations have been planned with island platforms. In the elevated section, stations have been planned with side platforms to avoid the viaduct structure from flaring in and out at stations, which obstructs the road traffic below. Care has been taken to locate stations on straight alignment. However, in some stations, site constraints have become the deciding criteria and a curve of 1000-m radius has been introduced.

5.6 SEQUENCE OF STATIONS

The sequence of stations along with their respective chainages, site and platform characteristics are presented in the Table 5.12 & 5.13.

Table 5.12- Station Location Characteristics

S. No.	Name of Station	Chainage (in m)	Distance from previous station (in m)	Rail level (in m)	Ground Level (in m)	Platform type	Alignment
Corridor 1 : PimpriChinchwad (PCMC) to Swargate							
	Dead End	(-)450.000	-				
1	PCMC	0.000	-	588.250	575.200	Side	Elevated
2	Tukaram Nagar	1763.264	1763.264	575.800	562.870	Side	Elevated

S. No.	Name of Station	Chainage (in m)	Distance from previous station (in m)	Rail level (in m)	Ground Level (in m)	Platform type	Alignment
3	Bhosari (Nashik Phata)	2974.275	1211.011	570.400	557.250	Side	Elevated
4	Kasarwadi	3748.615	774.340	574.200	561.240	Side	Elevated
5	Fugewadi	4923.064	1174.449	564.200	550.500	Side	Elevated
6	Dapodi	6018.188	1095.124	564.200	555.600	Side	Elevated
7	Bopodi	7206.181	1187.993	568.600	555.670	Side	Elevated
8	Khadki	7977.395	771.214	572.700	559.740	Side	Elevated
9	RangeHill	10185.226	2207.831	562.200	552.700	Side	Elevated
10	Shivaji Nagar	11789.640	1604.414	538.500	551.100	Island	Underground
11	A S I	12432.292	642.652	542.500	554.870	Island	Underground
12	P M C	12848.000	415.708	549.000	551.660	Island	Underground
13	BudhwarPeth	13866.261	1018.261	541.500	556.500	Island	Underground
14	Mandai	14742.084	875.823	549.000	562.610	Island	Underground
15	Swargate	15688.959	946.875	563.000	576.200	Island	Underground
	Dead End	16138.959	450.000	563.000	576.630	-	Underground

Table 5.13 - Station Location Characteristics

S. No.	Name of Station	Chainage (in m)	Distance from previous station (in m)	Rail level (in m)	Ground Level (in m)	Platform type	Alignment
Corridor 2-Vanaz (Kothrud Depot) to Ramwadi							
	Dead End	-684.790					
1	Vanaz	0.000	-	596.500	584.278	Side	Elevated
2	Anand Nagar	994.699	994.699	595.000	582.250	Side	Elevated
3	Ideal Colony	1900.000	905.301	586.806	575.222	Side	Elevated
4	Nal Stop	2875.274	975.274	574.700	562.000	Side	Elevated
5	GARWARE COLLEGE	3878.2	1004.283	567.00	553.80	Side	Elevated
6	DECCAN	4629.8	751.53	558.70	544.434	Side	Elevated
7	SAMBHAJI PARK	5222.9	593.15	561.10	547.402		
8	PMC	6053.2	830.31	561.70	548.067	Side	Elevated
9	CIVIL COURT	6568.1	514.91	563.20	549.602	Side	Elevated
10	MangalwarPeth	7671.332	1056.541	564.500	551.850	Side	Elevated
11	Pune Railway Station	8584.185	376.696	569.500	556.700	Side	Elevated
12	Ruby Clinic	9379.712	795.527	567.500	554.730	Side	Elevated
13	Bund Garden	10430.686	1050.974	561.600	548.670	Side	Elevated
14	Yerawada	11292.383	861.697	560.500	545.173	Side	Elevated
15	Kalyani Nagar	12660.667	1368.284	568.000	555.000	Side	Elevated
16	Ramwadi	13789.667	1129.000	570.300	557.350	Side	Elevated
	Dead End	14239.667	450.000				

5.7 PLANNING AND DESIGN CRITERIA FOR STATIONS

1. The stations can be divided into public and non-public areas (those areas where access is restricted). The public areas can be further subdivided into paid and unpaid areas.
2. The platform level has adequate assembly space for passengers for both normal operating conditions and a recognized abnormal scenario.
3. The platform level at elevated stations is determined by a critical clearance of 5.5 m under the concourse above the road intersection, allowing 3.5 m for the concourse height, about 1 m for concourse floor and 1.5 m for structure of tracks above the concourse. Further, the platforms are 1.09 m above the tracks. This would make the rail level in an elevated situation at least 12.5 above ground.

4. In the underground stations, platform level is determined by a critical clearance of 2.50 m above the station box, which would be 13.7 m high. Allowing about 80 cm for the box structure, ~70 cm for rails /supporting structure and 1.09 m for rail to platform ht, would make the platforms in an underground situation at least 13.5 m below ground.
5. The concourse contains automatic fare collection system in a manner that divides the concourse into distinct areas. The 'unpaid area' is where passengers gain access to the system, obtain travel information and purchase tickets. On passing through the ticket gates, the passenger enters the 'paid area', which includes access to the platforms.
6. The arrangement of the concourse is assessed on a station-by-station basis and is determined by site constraints and passenger access requirements. However, it is planned in such a way that maximum surveillance can be achieved by the ticket hall supervisor over ticket machines, automatic fare collection (AFC) gates, stairs and escalators. Ticket machines and AFC gates are positioned to minimize cross flows of passengers and provide adequate circulation space.
7. Sufficient space for queuing and passenger flow has been allowed at the ticketing gates.
8. Station entrances are located with particular reference to passenger catchment points and physical site constraints within the right-of-way allocated to the MRTS.
9. Office accommodation, operational areas and plant room space is required in the non-public areas at each station. The functions of such areas are given in Table 5.13.
10. The DG set, bore well pump houses and ground tank would be located generally in one area on ground.
11. The system is being designed to maximize its attraction to potential passengers and the following criteria have been observed:
 - Minimum distance of travel to and from the platform and between platforms for transfer between lines.
 - Adequate capacity for passenger movements.
 - Convenience, including good signage relating to circulation and orientation.
 - Safety and security, including a high level of protection against accidents.
12. Following requirements have been taken into account:
 - Minimum capital cost is incurred consistent with maximising passenger attraction.
 - Minimum operating costs are incurred consistent with maintaining efficiency and the safety of passengers.

- Flexibility of operation including the ability to adapt to different traffic conditions changes in fare collection methods and provision for the continuity of operation during any extended maintenance or repair period, etc.
 - Provision of good visibility of platforms, fare collection zones and other areas, thus aiding the supervision of operations and monitoring of efficiency and safety.
 - Provision of display of passenger information and advertising.
13. The numbers and sizes of staircases/escalators are determined by checking the capacity against AM and PM peak flow rates for both normal and emergency conditions such as delayed train service, fire etc.
 14. In order to transfer passengers efficiently from street to platforms and vice versa, station planning has been based on established principles of pedestrian flow and arranged to minimize unnecessary walking distances and cross-flows between incoming and outgoing passengers.
 15. Passenger handling facilities comprise of stairs/escalators, lifts and ticket gates required to process the peak traffic from street to platform and vice-versa (these facilities must also enable evacuation of the station under emergency conditions, within a set safe time limit).

5.8 TYPICAL ELEVATED STATION

The station is generally located on the road median. Total length of the station is 140m. All the stations are two-level stations. The concourse is concentrated in a length of about 70 m in the middle of the station, with staircases leading from either side of the road. The maximum width of the station at concourse is 35 m and at the narrowest part is 16.5 m. Passenger facilities like ticketing, information, etc as well as operational areas are provided at the concourse level. Typically, the concourse is divided into public and non-public zones. The non-public zone or the restricted zone contains station operational areas such as Station Control Room, Station Master's Office, Waiting Room, Meeting Room, UPS & Battery Room, Signaling Room, Train Crew Room & Supervisor's Office, Security Room, Station Store Room, Staff Toilets, etc. The public zone is further divided into paid and unpaid areas. Auxiliary Service station is provided on the ground nearby as per availability of land.

Since the station is in the middle of the road, minimum vertical clearance of 5.5-m has been provided under the concourse. Platforms are at a level of about 12.5-m from the road. To reduce physical and visual impact of the elevated station, stations have been made narrow towards the ends.

With respect to its spatial quality, an elevated Metro structure makes a great impact on the viewer as compared to an At-grade station. The positive dimension of this impact has been accentuated to enhance the acceptability of an elevated station and the above ground section

of tracks. Structures that afford maximum transparency and are light looking have been envisaged. A slim and ultra-modern concrete form is proposed, as they would look both compatible and modern high-rise environment as well as the lesser-built, low-rise developments along some parts of the corridor.

Platform roofs, that can invariably make a structure look heavy, have been proposed to be of steel frame with aluminium cladding to achieve a light look. Platforms would be protected from the elements by providing an overhang of the roof and sidewalls would be avoided, thereby enhancing the transparent character of the station building. In order to allow unhindered traffic movement below the stations, portals across the road have been proposed in the concourse part, over which the station structure would rest. The rest of the station structure is supported on a single column, which lies unobtrusively on the central verge.

5.9 TYPICAL UNDERGROUND STATION

The typical underground station is a two-level station with platforms at the lower level and concourse on the upper level. Concourses are provided at the two ends only in such a manner that the total height of underground station, and hence the cost, is kept to the minimum. The upper level has, in addition to the concourse, all the passenger amenities, ECS plant rooms, electrical and S&T equipment rooms, station operation areas such as Station Control Room, Station Master's Office, Waiting Room, Meeting Room, UPS & Battery Room, Signalling & Train Crew Room, Train Crew Supervisor's Office, Security & Station Store Room, Staff Toilets, etc. Lower level has platforms, tracks, seepage sump, pump room and similar ancillary spaces beyond the platforms on either side.

Ventilation shafts, equipment hatch, entrances and chiller plants for ECS plant are aboveground structures associated with the underground station and are being provided on the open spaces by the road side. Generally four entrances have been provided to the station, two at each end (one each from either side of the road). Two emergency staircases are also being planned in the traffic islands. Other aboveground structures are suitably located near the station.

Structure of the underground station is essentially a concrete box about 20-m wide, 14.6-m high and 225-m long with an intermediate slab. Sides of the box are made of 1.2-m thick RCC.

Table 5.14- Station Accommodation

1. Station Control Room	2. Cleaner's Room
3. Station Master's Office	4. Security Room
5. Information & Enquiries	6. First Aid Room
7. Ticket Office	8. Miscellaneous Operations Room
9. Ticket Hall Supervisor & Excess Fare Collection (Passenger Office)	10. Platform Supervisor's Booth
11. Cash and Ticket Room	12. Traction Substation (alternate Stations)
13. Staff Area	14. Fire Tank and Pump Room
15. Staff Toilets	16. Commercial Outlets and Kiosks
17. Station Store Room	18. UPS and Battery Room
19. Refuse Store	20. Signaling / Communication Room

5.10 PASSENGER AMENITIES

Passenger amenities such as ticketing counters/automatic ticket vending machines, ticketing gate, etc. are provided in the concourse. Uniform numbers of these facilities have been provided for system wide uniformity, although the requirement of the facilities actually varies from station to station. The same applies to provision of platform widths and staircase/escalators. Maximum capacity required at any station by the year 2031 for normal operation has been adopted for all stations. For this purpose, *peak minute traffic* is assumed to be 2% of the *peak hour traffic*. For checking the adequacy of platform area, stair widths and requirement additional of emergency evacuation stairs, a maximum accumulation of passengers in the station has been considered to be comprising waiting passengers at the platform (including two missed headways) and section load expected to be evacuated at the station in case of an emergency.

5.10.1 Concourse

Concourse forms the interface between street and platforms. In elevated stations, this is contained in a length of about 90-m in the middle of the station. This is where all the passenger amenities are provided. The concourse contains automatic fare collection system in a manner that divides the concourse into distinct *paid* and *unpaid* areas. The '*unpaid area*' is where passengers gain access to the system, obtain travel information and purchase tickets. On passing through the ticket gates, the passenger enters the '*paid area*', which includes access to the platforms. The concourse is planned in such a way that maximum surveillance can be achieved by the ticket hall supervisor over ticket machines, automatic fare collection (AFC) gates, stairs and escalators. Ticket machines and AFC gates are

positioned to minimize cross flows of passengers and provide adequate circulation space. Sufficient space for queuing and passenger flow has been allowed in front of the AFCs.

5.10.2 Ticketing Gates

Ticketing gates' requirement has been calculated taking the gate capacity as 45 persons per minute per gate. Passenger forecast for the horizon year 2031 has been used to compute the maximum design capacity. At least two ticketing gates shall be provided at any station even if the design requirement is satisfied with only one gate. Uniform space has been provided in all stations where gates can be installed as and when required.

5.10.3 Ticket Counters and Ticket Issuing Machines (TIMs)

It is proposed to deploy manual ticket issuing in the beginning of the operation of the line. At a later stage, automatic TIMS would be used for which space provision has been made in the concourse. At present, ticket counters would be provided, which would be replaced with TIMS in future. Capacity of manual ticket vending counters is taken to be 10 passengers per minute and it is assumed that only 40% of the commuters would purchase tickets at the stations while performing the journey. The rest are expected to buy prepaid tickets or prepaid card, etc. Accordingly, the requirement of ticket counters has been calculated and the same provided for in the plans.

5.10.4 Platforms

A uniform platform width of 10-m wide is proposed for the underground stations. In elevated stations, 4.5m wide side platforms have been proposed. These platform widths also have been checked for holding capacity of the platform for worst-case scenario.

5.10.5 Stairs, Escalators and Lifts

Provision has been made for escalators in the paid area i.e. from concourse to platforms. On each platform, one escalator has been proposed. In addition, two staircases with a combined width of 6 m are provided on each platform connecting to the concourse. These stairs and escalator together provide an escape capacity adequate to evacuate maximum accumulated passengers in emergency from platforms to concourse in 5.5 minutes. Lifts have been provided one each on either platform, to provide access for elderly and disabled. Since the rise to road from the concourse is about 8m, it is proposed to provide escalators and lifts in addition to stairs for vertical movement of passengers from street to concourse.

5.11 TRAFFIC INTEGRATION

5.11.1 Concept of Traffic Integration

The objective of an integrated transport system and traffic movement is to offer maximum advantage to commuters and society from traffic and planning consideration. Various modes of transport need to be integrated in a way that each mode supplements the other. A large proportion of MRTS users will come to and depart from various stations by public, hired and private modes, for which integration facilities need to be provided at stations to ensure quick and convenient transfers.

In order to ensure that entire MRTS function as an integrated network and provides efficient service to the commuter, the following steps have been identified:

- Suitable linkages are proposed so that various corridors of MRTS are integrated within themselves, with existing rail services and with road based modes.
- Facilities needed at various stations are planned in conformity with the type of linkages planned there.

Traffic and transport integration facilities are provided for two different types of linkages:

- Feeder links to provide integration between various MRTS corridors and road based transport modes i.e. public, hired, and private vehicles.
- Walk links to provide access to the pedestrians.

5.11.2 Approach Adopted in Planning Traffic Integration Facilities

Integration facilities at MRTS stations include approach roads to the stations, circulation facilities, pedestrian ways and adequate circulation areas for various modes likely to come to important stations including feeder bus/mini-buses. Parking for private vehicles has been proposed close to the station entrances. The computer model employed for traffic demand projections provides also a breakup of station loads between passengers arriving by walk or by vehicular modes. The vehicular component has been further broken up among hired and private modes on station-to-station basis, by assessing the socio-economic profile of the catchment areas and the distance likely to be traveled by commuters before and after using the MRTS. In doing so, feeder buses being planned as part of the project as well as interchange with railways has been considered. Given below is station wise traffic integration requirement. In case at a particular station, suitable land is not available, effort has been made to provide equivalent space on the adjacent stations, assuming that park and ride commuters will shift to which ever station such a facility is available.

5.12 CIVIL STRUCTURES

5.12.1 Underground Construction

As in the underground section most of the area is either built-up or passing under arterial Road, it is proposed to tunnel through Tunnel Boring Machine (TBM) in the overburden soil mass. This will reduce cost substantially and inconvenience to general public during construction. Tunnel excavation for a major part of this underground section is expected to be carried out by Tunnel Boring Machines. There is some smaller section along the underground part of the alignment where Cut & Cover method has been considered for construction after Switch Over Ramp (SOR). Tunnel boring machines (TBMs) capable of drilling in soft soil with a finished internal diameter of 5.2 m. can be successfully employed for boring tunnels through this stratum. The tunnels are proposed with a minimum soil cover of 6 m.

ASI, PMC, Budhwarpeth and Mandai have been planned with NATM, where as Shivaji Nagar and Swargate have been planned by cut and cover.

5.12.2 Underground Stations

Two of the underground stations out of six have been proposed as cut and cover with top-down method. The diaphragm walls for such station constructions would be 80 to 100 cm. thick and will function as a permanent side wall of the station. It is, therefore, necessary to construct the diaphragm walls absolutely watertight and with the required concrete strength as has been done in the Delhi Metro station constructions. By resorting to top-down method the surface could be restored quickly and further excavations and construction of the station will not hamper the surface activity.

5.12.3 Cut and Cover Method of Construction of Underground Stations

Cut and Cover mainly consists of following steps:

1. Diversion of utilities
2. Construction of support walls
3. Excavation between the support walls along with the installation of struts between the two walls to keep them in position.
4. Construction of tunnel/structure and removal of temporary struts.
5. Back filling and restoration of the surface

Utility Diversion

It is suggested that all utilities falling within excavation area are to be diverted away in advance to avoid damage to such utilities during the excavation/ construction phase. The cross utilities, however has to be kept supported. It is suggested that pressure water pipelines crossing the proposed cut area are provided with valves on both sides of the cut so that the cut area can be isolated in case of any leakage to the pipeline avoid flooding of the cut/damage to the works.

Support Walls

Most commonly used support wall is RCC Diaphragm Wall. The advantage of diaphragm wall is that the same can be used as part of permanent structure. The modern techniques are now available where water-stop can be inserted at the joints of two diaphragm wall panels to avoid seepage through the joints. It is also now possible to ensure the verticality of the diaphragm wall panels to avoid any infringement problem later on. Typically the diaphragm wall of 80 cm to 1 meter thickness is sufficient to do the cut and cover construction. The various advantages of diaphragm wall are as follows.

- (a) It is rigid type of support system and therefore ensures the maximum safety against settlement to the adjacent structures.
- (b) Can be used as part of the permanent structure and, therefore, considered economical.
- (c) With diaphragm wall it is possible to construct an underground structure by top down method. In this method top slab is casted once the excavation is reached to the top slab level with rigid connections to the diaphragm wall which can be achieved by leaving couplers in the diaphragm wall reinforcement at appropriate level. This top slab then acts as strut between the two support walls and gives much more rigidity and safety to the construction. Excavation thereafter can be completed. This also helps in restoration of the surface faster without waiting for full structure to be completed.

The other support walls which can be used depending on the site conditions are as follows.

- (a) **Sheet Piles** : 'Z' / 'U' sheet piles can be used as temporary support wall. This can be advantageous where it is possible to re-use the sheet pile again and again and therefore, economy can be achieved. However the main concern remains, driving of sheet piles causes vibrations/noise to the adjacent buildings. This may sometimes lead to damage to the building and most of the time causes inconvenience to the occupants of the building. Situation becomes more critical if sensitive buildings are adjacent to the alignment like hospitals, schools, laboratories, etc. Silent pile driving equipments however are now available and can be used where such problems are anticipated.

- (b) **Retaining Casing Piles :** This suitable for situation where the cut and cover is to be done in partly soil and partly rock. The top soil retaining structure can be with the help of casing pile is then grouted with then cement slurry. This is considered suitable in case of Shallow level, non-uniform, uneven nature of rock head surface which rendered the construction of sheet piles/diaphragm wall impracticable. These are suitable up to 7-meter depth. The common diameter used for such casing pile is 200-250 meter dia.
- (c) **Soldier Piles and Lagging:** Steel piles (H Section or I section) are driven into the ground at suitable interval (normally 1-1.5 mtr.) centre-to-centre depending on the section and depth of excavation. The gap between two piles is covered with suitable lagging of timber planks/shot-creting /steel sheets/GI sheets during the process of excavation.
- (d) **Secant Piles:** are cast-in-situ bored piles constructed contiguously to each other so that it forms a rigid continuous wall. This is considered an alternative to diaphragm wall where due to soil conditions it is not advisable to construct diaphragm wall from the consideration of settlement during the trenching operation. In this case 800 to 1000m.m. dia. piles area quite common in use Two alternative soft piles in such a way that the new pile partly cuts into earlier constructed piles. And this pile now is constructed with suitable reinforcement. With this alternative soft and hard pile is constructed. This has got all the advantages of diaphragm wall. However, this wall cannot be used as part of permanent structure and permanent structure has to be constructed in- side of this temporary wall.

Anchors:

As an alternative to the struts, soil/rock anchors can be used to keep theses support walls in position. This gives additional advantage as clear space is available between two support walls and progress of excavation, construction can be much faster as compared to the case where large number of struts is provided which create hindrance to the movement of equipments and material.

The combination of all the type of retaining walls, struts./anchors is necessary for the project to suit the particular site. Based on the above broad principle, the support walls system for cut and cover shall be chosen for particular locations.

5.12.4 Elevated Section

Choice of Superstructure

The choice of superstructure has to be made keeping in view the ease of construct ability and the maximum standardization of the formwork for a wide span ranges.

The segmental construction has been chosen mainly due to the following advantages :

- Segmental construction is an efficient and economical method for a large range of span lengths and types of structures. Structures with sharp curves and variable super elevation can be easily accommodated.
- Segmental construction permits a reduction of construction time as segments may be manufactured while substructure work proceeds, and assembled rapidly thereafter.
- Segmental construction protects the environment as only space required for foundation and sub-station is required at site. The superstructure is manufactured at a place away from busy areas and placement of superstructure is done with the system erected from piers at heights.
- Segments are easy to stack in the casting yard/sticking yard in more than one layer, thereby saving in requirement of space.
- It is easier to transport smaller segments by road trailers on city roads.
- It is easy to incorporate last minute changes in span configuration if the site situation so warrants.
- Interference to the traffic during construction is significantly reduced.
- Segmental construction contributes towards aesthetically pleasing structures and good finishes.
- The overall labour requirement is less than that for conventional methods.
- Better quality control is possible in the casting yard.
- During construction, the technique shows an exceptionally high record of safety.

5.12.5 Types of Superstructures for Elevated Section

- (A) Pre-cast segmental box girder using external unbonded tendon
- (B) Pre-cast segmental U-Channel Superstructure with internal pre-stressing.

Comparative advantages/disadvantages of the above two types are given below :

A. Precast Segmental Box Girder using External Unbonded Tendon.

This essentially consists of precast segmental construction with external prestressing and dry joints and is by far most preferred technique in fast track projects. In such construction the prestressing is placed outside the structural concrete (inside the box section) and protected with high density polyethylene tubes, which are grouted with special wax or cement. The match cast joints at the interface of two segments are provided with shear keys as in traditional segmental construction. However, epoxy is dispensed with because water tight seal at the segment joints is not required in association with external tendons.

The main advantages of dry-jointed externally prestressed precast segmental construction can be summarized as follows:-

- Simplification of all post-tensioning operations, especially installation of tendons.
- Reduction in structural concrete thickness as no space is occupied by the tendons inside the concrete.
- Good corrosion protection due to tendons in polyethylene ducts; the grout inspection is easier and leaks, if any, can be identified during the grouting process.
- Simplified segment casting. There is no concern about alignment of tendons. Increased speed of construction.
- The elimination of the epoxy from the match-cast joints reduces costs and increases speed of construction further.
- Replacement of tendons in case of distress is possible and can be done in a safe and convenient manner.
- Facility for inspection and monitoring of tendons during the entire service life of the structure.

B. Precast Segmental U-Channel Superstructure with Internal Pre-stressing.

The single U type of viaduct structure is also a precast segmental construction with internal prestressing and requires gluing and temporary prestressing of segments. The match cast joints at the interface of two segments are also provided with shear keys. The main advantages for this type of structural configuration of superstructure are:

1. Built in sound barrier.
2. Built in cable support and system function.
3. Possibility to lower the longitudinal profile by approximately 1m compared to conventional design.
4. Built in structural elements capable to maintain the trains on the bridge in case of derailment (a standard barrier design allow this)
5. Built in maintenance and evacuation path on either side of the track.

However, 'U' section has following disadvantages:

- (i) Inefficient structure sections
- (ii) Requires cross pre-stressing of pier segments
- (iii) At X-over locations the girders are to be connected at slab level hence changing of bearing at later stage becomes very difficult.
- (iv) Costly than Box girder.

5.13 CONSTRUCTION METHODOLOGY

Pre-Cast Construction

For the elevated sections it is recommended to have pre-cast segmental construction for super structure for the viaduct. For stations also the superstructure is generally of pre-cast members. The pre-cast construction will have following advantages:-

- Reduction in construction period due to concurrent working for substructure and superstructure.
- For segmental, pre-cast element (of generally 3.0m length), transportation from construction depot to site is easy and economical.
- Minimum inconvenience is caused to the public utilising the road as the superstructure launching is carried out through launching girder requiring narrow width of the road.
- As the pre-cast elements are cast on production line in a construction depot, very good quality can be ensured.
- The method is environment friendly as no concreting work is carried at site for the superstructure.

Casting of Segments

For viaducts segmental pre-cast construction requires a casting yard. The construction depot will have facilities for casting beds, curing and stacking area, batching plant with storage facilities for aggregates and cement, site testing laboratories, reinforcement steel yard and fabrication yard etc. An area of about 2.5 Hact. To 3 Hact is required for each construction depot.

For casting of segments both long line and short line method can be adopted. However the long line method is more suitable for spans curved in plan while short line method is good for straight spans. A high degree of accuracy is required for setting out the curves on long line method for which pre calculation of offsets is necessary. Match casting of segments is required in either method. The cast segments are cured on the bed as well as in stacking yard. Ends of the segments are to be made rough through sand blasting so that gluing of segments can be effective.

The cast segment will be transported on trailers and launched in position through launching girders.

Launching Scheme

Launching girder is specially designed for launching of segments. The suggested launching scheme is designed in such a way that initially the launching girder is erected on pier head at one end of the work. The segments are lifted in sequence and when the lifting is over; they are dry matched while hanging from the launching girder. After dry matching, the segments are glued with epoxy and pre-stressed from one end. The girder is lowered on the temporary/permanent bearings after pre-stressing. The launching girder then moves over the launched span to next span and the sequences continue.

5.13.1 Structural System of Viaduct

Superstructure

The superstructure of a large part of the viaduct comprises of simply supported spans. However at major crossing/over or along existing bridge, special steel or continuous unit will be provided.

Normally the Box Girder having a soffit width of about 4.0 m (approx) accommodates the two tracks situated at 4.1m center to center (c/c). The Box Girder superstructure for almost all the simply supported standard spans will be constructed by precast prestressed segmental construction with epoxy bonded joints.

The max spans c/c of piers of standard simply supported spans constructed by precast segmental construction technique has been proposed as 28.0m. The usual segments shall be 3.0m in length except the Diaphragm segments, which shall be 2.0m each. The other standard spans (c/c of pier) comprises of 25.0m, 31.0m, 22.0m, 19.0m & 16.0m, which shall be made by removing/adding usual segments of 3.0m each from the center of the span.

The pier segment will be finalized based on simply supported span of 31.0m and the same will be also kept for all simply supported standard span.

For major crossing having spans greater than 31.0m, special units normally of 3 –span construction or steel girders have been envisaged.

All these continuous units (in case provided at obligatory location) will be constructed by cast-in-situ balanced cantilever construction technique.

Substructure

The viaduct superstructure will be supported on single cast-in-place RC pier.

The shape of the pier follows the flow of forces. For the standard spans, the pier gradually widens at the top to support the bearing under the box webs.

At this preliminary design stage, the size of pier is found to be limited to 1.8m to 2.0m diameter of circular shape for most of its height so that it occupies the minimum space at ground level where the alignment often follows the central verge of existing roads.

To prevent the direct collision of vehicle to pier, a Jersey Shaped crash barrier of 1.0m height above existing road level has been provided all around the pier. A gap of 25mm has been also provided in between the crash barrier and outer face of pier. The shape of upper part of pier has been so dimensioned that a required clearance of 5.5m is always available on road side beyond vertical plane drawn on outer face of crash barrier. In such a situation, the minimum height of rail above the existing road is 8.4m.

The longitudinal center to center spacing of elastomeric/pot bearing over a pier would be about 1.8m. The space between the elastomeric bearings will be utilized for placing the lifting jack required for the replacement of elastomeric bearing. An outward slope of 1:200 will be provided at pier top for the drainage due to spilling of rainwater, if any.

The transverse spacing between bearings would be 3.2m (to be studied in more details).

The orientation and dimensions of the piers for the continuous units or steel girder (simply supported span) have to be carefully selected to ensure minimum occupation at ground level traffic. Since the vertical and horizontal loads will vary from pier to pier, this will be catered to by selecting the appropriate structural dimensions.

5.14 FOUNDATIONS RECOMMENDATIONS

Substratum consists of clayey silt/ silty clay / silty sand followed by weathered rock / hard rock in the proposed alignment. No rock has been encountered up to depth of exploration at some stretches also. Pile foundations have been recommended for the foundation as per the

stratum encountered. Hence, pile foundations with varying pile depths depending on depth of rock from ground level have to be provided on a case-by-case basis.

5.15 CONSTRUCTION METHODS

Deck – Simple Spans

Salient features of the precast segmental construction method technique as envisaged for the project under consideration are indicated below:

The superstructure shall be constructed “span by span” sequentially, starting at one end of a continuous stretch and finishing at the other end. Nos. of launching girders may be required so as to work on different stretches simultaneously to enable completion of the project in time.

The number of “breaks” in the stretch can be identified by nos of continuous units.

The suggested method of erection will be detailed in drawings to be prepared, at the time of detailed design. The launching girder (or, more accurately, the “assembly truss”) is capable of supporting the entire dead load of one span and transferring it to the temporary brackets attached to the pier. The governing weight of the segments will be of the order of 50t (to be finalized). The launching girder envisaged will be slightly greater than two span lengths. It must be able to negotiate curves in conjunction with temporary brackets.

Transportation of segments from casting yard to the point of erection will be effected by appropriately designed low-bedded trailers (tyre-mounted). The segments can be lifted and erected using erection portal gantry moving on launching girder.

Box girder segments shall be match cast at the casting yard before being transported to location and erected in position. Post-tensioned cables shall be threaded in-situ and tensioned from one end. It is emphasized that for precast segmental construction only one-end prestressing shall be used.

The prestressing steel and prestressing system steel accessories shall be subjected to an acceptance test prior to their actual use on the works. The tests for the system shall be as per FIP Recommendations as stipulated in the special specifications. Only multi-strand jacks shall be used for tensioning of cables. Direct and indirect force measurement device (e.g. Pressure Gauge) shall be attached in consultation with system manufacturer.

The Contractor shall be responsible for the proper handling, lifting, storing, transporting and erection of all segments so that they may be placed in the structure without damage. Segments shall be maintained in an upright position at all times and shall be stored, lifted

and/or moved in a manner to prevent torsion and other undue stress. Members shall be lifted, hoisted or stored with lifting devices approved on the shop drawings.

Epoxy Bonded Joints and Shear Keys

A minimum compressive stress of 3 kg/sqcm shall be provided uniformly over the cross-section for the closure stress on the epoxied joint until the epoxy has set. The curing period for application of the compressive stress, method of mixing and application of epoxy and all related aspects including surface preparation shall be as per approved manufacturer's specifications.

The purpose of the epoxy joint, which is about 1mm on each mating surface, shall be to serve as lubricant during segment positioning, to provide waterproofing of the joints for durability in service conditions and to provide a seal to avoid cross-over of grout during grouting of one cable into other ducts.

The epoxy shall be special purpose and meet requirements of relevant provision of FIP (International Federation of Prestressed Concrete)

The temporary compressive stress during the curing period shall be applied by approved external temporary bar prestressing (such as Macalloy or Diwidag bar systems or approved equivalent).

5.16 CONSTRUCTION OF STATIONS

It is proposed to construct the elevated stations with elevated concourse over the road at most of the locations to minimize land acquisition. To keep the rail level low, it is proposed not to take viaduct through the stations. Thus a separate structural configuration is required (although this may necessitate the break in the launching operations at each station locations)

Sub-structure for the station portion will also be similar to that of viaduct and will be carried out in the same manner. However, there will be single viaduct column in the station area, which will be located on the median and supporting the concourse girders by a cantilever arm so as to eliminate the columns on right of way.

Super-structure will consist of 3 precast U Girders for supporting the track structure and I Girder / Double T Girders for supporting the platform and concourse areas. A pre-cast or cast in situ prestressed cross girder will be required over the middle piers for supporting platform structure. Box shaped in situ prestressed cantilever cross girders are planned for supporting the concourse girders and escalators at mezzanine level. All the members will be pre-cast in a construction depot and launched at site through cranes.

5.16.1 Grade of Concrete

It is proposed to carry out construction work with design mix concrete through computerized automatic Batching Plants with following grade of concrete for various members as per design requirement/durability considerations.

i) Piles	-	M -35
ii) Pile cap and open foundation	-	M -35
iii) Piers	-	M -40
iv) All precast element for viaduct and station	-	M -45
v) Cantilever piers and portals	-	M -45
	-	M -60
vi) Other miscellaneous structure	-	M -30

For all the main structures, permeability test on concrete sample is recommended to ensure impermeable concrete.

5.16.2 Reinforcement and pre-stressed Steel

It is proposed to use HYSD 415 or TMT steel as reinforcement bars.

For pre-stressing work, low relaxation high tensile steel strands with the configuration 12 T 13 and or 19 K 15 is recommended (confirming to IS:14268).

5.16.3 Road width required during construction

As most of the construction is to be carried out on the middle of the road, central two lanes including median will be required for construction activities. During piling and open foundation work, a width of about 9 m will be required for construction and the same will be barricaded. It is proposed that two lanes are provided for traffic on either sides during construction by widening of roads, if necessary. In certain cases, one way traffic may be resorted to.

All these actions will require a minimum period of about 4 to 6 months. During this period, the implementing agency can go ahead with the following preliminary works:

- i) Preliminary action for diversion of utility and preparation of estimates there of.
- ii) Reservation of land along the corridor, identification and survey for acquisition.

Once the Corporation is formed, the Corporation has to take action for appointment of consultant for Project Management and proof checking including preparation of tender

documents. Simultaneously, action is also to be taken for detailed design for structures for elevated corridors.

5.17 GEO-TECHNICAL INVESTIGATIONS

5.17.1 Details of Bore Holes

Investigation Works

Geotechnical investigation work at site was carried out to determine the existing subsoil strata, proposed type & depth of foundations and safe bearing capacity of foundations required for the proposed two Metro Corridors in Pune Metropolitan City based on the results of 44 boreholes.

Boring in Soil and Rock

Core drilling was carried out by using rotary type of boring machine with diamond bits of N_x size. Casing of 100/150 mm dia was advanced up to the firm strata as per IS1892 (1979). The description of bore logs for bore holes drilled as per IS-5313. The bore logs are as under:

Table: 5.15- Borehole Details

S.No.	Specified Locations	Bore Hole No.	Depth below ground level (m)
1	Sanghvi Naka to Agricultural College	BH-1	16.50
2	-do-	BH-2	13.00
3	Natawadi Road to Swargate	BH-15	25.15
4	-do-	BH-16	25.00
5	-do-	BH-17	19.50
6	-do-	BH-18	11.00
7	-do-	BH-19	11.10
8	-do-	BH-21	25.00
9	-do-	BH-22	25.00
10	-do-	BH-23	25.00
11	-do-	BH-24	26.30
12	-do-	BH-25	15.00
13	Bund Garden to Ramwadi Octroi Naka	BH-26	12.00
14	-do-	BH-27	19.50
15	Wakde Wadi to Pimpri Chowk	BH-33	15.00

S.No.	Specified Locations	Bore Hole No.	Depth below ground level (m)
16	-do-	BH-34	12.60
17	-do-	BH-35	16.00
18	-do-	BH-36	14.50
19	-do-	BH-37	11.50
20	-do-	BH-38	14.00
21	-do-	BH-39	9.00
22	-do-	BH-40	15.00
23	-do-	BH-41	12.00
24	-do-	BH-42	15.50
25		BH-54	10.50
26	Jangli Maharaj Path	BH-55	14.50
27	-do-	BH-56	18.80
28	-do-	BH-57	17.90
29	-do-	BH-58	17.90
30	-do-	BH-59	19.50
31	-do-	BH-60	15.10
32	-do-	BH-61	19.90
33	-do-	BH-62	13.50
34	-do-	BH-63	11.20
35	-do-	BH-64	13.75
36	-do-	BH-65	12.50
37	-do-	BH-66	11.75
38	-do-	BH-67	13.00
39	-do-	BH-68	16.30
40	-do-	BH-70	11.50
41	-do-	BH-71	8.00
42	-do-	BH-72	10.20
43	-do-	BH-74	10.00
44	-do-	BH-75	10.50

5.17.2 Field Tests & Laboratory Tests

Standard Penetration Tests

The Standard Penetration Tests were conducted in exploratory bore hole at different depths as per the procedure stipulated in IS: 2131. Number of blows required for each 15 cm penetration up to 45 cm were recorded and the number of blows for later 30 cm penetration were counted as Standard Penetration Value(N).

Insitu Permeability Test in Overburden in BH 15,17,19,22,24,26,33, 36, 37, 39, 41, 42, 55, 57, 59, 61, 63, 65, 70, 74.

Insitu Permeability Test in BH 16, 21, 35, 40, 56, 66, 72, 75.
Grain Size Analysis

The Grain Size Analysis of different samples collected from boreholes were done as per IS: 2720(part IV).

Atterberg's Limits

The liquid limit and plastic limit were conducted as per IS: 2720(part V) on soil samples.

Field Content Density and Moisture

The Undisturbed Soil Samples were tested for field density and moisture content as per IS: 2720(part II).

Specific Gravity

The soil samples were tested for specific gravity as per IS: 2720(part III).

Direct Shear Test

The undisturbed soil samples were tested for direct shear tests.

Chemical Analysis of Soil

Chemical analysis of soil samples were conducted for PH, Sulphates (ppm) and for Chloride (ppm).

Chemical Analysis of Water

Chemical analysis of soil samples were conducted for PH, Sulphates (ppm) and for Chloride (ppm).

Rock Test Analysis

Rock samples were collected from the bore holes and tested for water absorption, porosity, dry density and compressed strength(kg/cm²).

5.18 RECOMMENDATIONS

Forty four boreholes are drilled in Pune Metropolitan Area for Pune Metro Rail Project. Three horizons are observed at proposed Pune Metro alignment.

First horizon observed is filled up soil followed by clayey soil with murum and boulders. The drilled thickness of this horizon varied from 0.00 m to 12.50 m. The N value in this horizon varied from 7 to more than 50.

The net allowable safe bearing capacity of filled up soil followed by clayey soil with murum is recommended as 10.00T/m² at a depth of 3.00 m below G.L.

Second horizon observed is light brownish to reddish gray weathered rock. The core recovery of rock mass varied from 5% to 82.67% and RQD of the rock mass varied from nil to 77%. The compressive strength of rock mass varied from 47.79 kg/cm² to 191.16 kg/cm².

The safe bearing capacity of light brownish to reddish gray weathered rock is recommended as 55.00T/m².

Third horizon observed is light olive gray to light medium brownish gray basalt rock. The core recovery of rock mass varied from 22% to 100% and RQD of the rock mass varied from nil to 100%. The compressive strength of rock mass varied from 184.62 kg/cm² to 456.32 kg/cm².

The safe bearing capacity of light olive gray to light medium brownish gray basalt rock is recommended as 225.00T/m².

5.19 UTILITY DIVERSIONS

5.19.1 Introduction

Besides the details of various aspects e.g. transport demand analysis, route alignment, station locations, system design, viaduct structure, geo-technical investigations etc. as brought out in previous chapters, there are a number of other engineering issues, which are required to be considered in sufficient details before really deciding on taking up any infrastructure project of such magnitude. Accordingly, following engineering items have been studied and described in this chapter:

- Existing utilities and planning for their diversion during construction, if necessary.
- Land acquisition necessary for the project both on permanent basis as well as temporary, including its break up between Government and private ownership.

5.19.2 Utility and Services

Large number of sub-surface, surface and over head utility services viz. sewers, water mains, storm water drains, telephone cables, O.H electrical transmission lines, electric poles, traffic signals, etc. are existing along the proposed alignment. These utility services are essential and have to be maintained in working order during different stages of construction, by temporary/permanent diversions or by supporting in position. Since these may affect construction and project implementation time schedule/costs, for which necessary planning/action needs to be initiated in advance.

Organisations/Departments with concerned utility services in Pune are mentioned in Table 5.16.

Table 5.16- Utility Responsibility Departments

S No	ORGANIZATION/ DEPARTMENT	UTILITY SERVICES
1.	Pune Metropolitan Water Supply and Sewerage Board.	Surface water drains, nallahs, Sewerage and drainage conduits, sewerage treatment plants, pumping stations, Water mains and their service lines, including hydrants, water treatment plants, pumping stations, Gardens etc.
2.	Public Works Deptt. (PWD)	Road construction & maintenance of State highways and Expressways.
4.	Bharat Sanchar Nigam Ltd. (BSNL)	Telecommunication cables, junction boxes, telephone posts, O.H. lines, etc.
5.	Pune Traffic Police	Traffic signal posts, junction boxes and cable connections, etc.
6.	District Revenue Office	Land Development & Housing etc.
7.	Railway	Railway crossings, signals, railway bridges, etc.

5.19.3 Sewer Lines, Storm Water Drains and Water Lines

The sewer/drainage lines generally exist in the service lanes i.e. away from main carriageway. However, in certain stretches, these have come near the central verge or under main carriageway, as a result of subsequent road widening.

The major sewer/drainage lines and water mains running across the alignment and likely to be affected due to location of column foundations are proposed to be taken care of by relocating on column supports of viaduct by change in span or by suitably adjusting the layout of pile foundations. Where, this is not feasible, lines will be suitably diverted. Provision has been made in the project cost estimate towards diversion of utility service lines. Investigations of underground utilities are in progress and details would be furnished in Final Report.

5.19.4 Above Ground Utilities

Above ground utilities namely street light, poles, traffic signal posts, telecommunication posts, junction boxes, trees etc, are also required to be shifted and relocated suitably during construction of elevated viaduct. Since these will be interfering with the proposed alignment. Approximate numbers of affected lamp/telecom elect. Posts & boxes are indicated in Table 5.17:

Table 5.17- Affected Above Ground Services

Section	LP	EP	TSP	TP	DP	HT	TR	CD
Corridor 1	326	48	25	9	27	65	246	10
Corridor 2	505	33	81	11	8	41	765	1

LP- Light Post ; EP - Electric Post; TSP - Traffic Signal Post; TP - Telephone Post; DP-high tension double poll; HT- high tension post ; TR-trees; CD-civil works

5.20 LAND REQUIRED FOR CORRIDORS

5.20.1 Land Requirement for Major Components

Availability of land is one of the major prerequisites for a project in cities like Pune. As the Metro alignment has to be planned on set standards and parameters, it becomes difficult to follow the road alignment. Apart from alignment the various structures like stations, parking facilities, traction sub stations, communication towers, etc. require large plots of land. The land being scare, costly and acquisition being complex process; the alignment is so planned that barest minimum land acquisition is involved. Land is mainly required for;

- Metro Structure (including Route Alignment), station Building, Platforms, Entry/Exit Structures, Traffic Integration Facilities, etc.
- Receiving/Traction Sub-stations
- Radio Towers
- Property Development.
- Temporary Construction Depots and work sites.
- Depot
 - Switch Over Ramps.

5.20.2 Land Required for Elevated Stretches

For elevated section, single pier supporting the viaduct will be located on the middle of road so that the existing roads remain in use as usual. Accordingly, necessary permission for using such right-of-way will have to be obtained from the concerned authorities. Elevated

stations are generally proposed with elevated concourse so that land is required only for locating the entry/exit structures. Traffic integration facilities are provided wherever the same are required but no land is proposed for acquisition.

The normal viaduct structure of elevated Metro is about 10 m (edge to edge) wide. Ideally the required right of way is 10m. However, for reasons of safety a clean marginal distance / setback of about 5 m is necessary from either edge of the viaduct (or 10 m on both sides of the center line) wherein no structures are to be located. In stretches, where the elevated alignment has to be located away from road, a strip of 17m width (with consideration of 3.5m clearance on either side to reduce land width), is proposed for acquisition, it ensures road access and working space all along the viaduct for working of emergency equipments and fire brigade.

5.20.3 Land for Underground Stretches

No land at surface is required permanently for underground section, except for small areas for entry/exit structures, traffic integration and ventilation shafts at stations. These will be located either on footpath edge or in front marginal open setback of the building along the road. All the stations in underground stretch are planned with island platforms.

5.20.4 Land for Switch-over Ramps

Switch-over ramps are required for transition from the underground to elevated section. The ramp covers a stretch at ground for the whole width of structure for two tracks (about 11 m including the protection works). The length of ramp above ground depends on the existing ground slope and the gradient provided on Metro alignment (normally 3% to 4%). Thus the ramp is to be located in an area where sufficient road width is available or in an open area.

5.20.5 Land for Stations

Provision of land for Traffic integration has been made on those stations only, where space is available. It is proposed to provide traffic integration facilities at all the following Metro stations. Land for these facilities has been identified and is given in **Table 5.18**:

Table 5.18 - Lands For Stations & Traffic Integration

S.NO.	PLOT NO.	AREA(m ²)	TYPE OF PROPERTY	OWNERSHIP	REMARKS
Corridor - I					
1	PCMC1	2483.97	Open	Government	New Construction
2	PCMC2	468.00	Open	Government	
3	STR1	2519.99	Open	Government	Sant. TukaRam Bus Stand
4	STR2	468.00	Open	Government	
5	BR1	2520.85	Hotel + Shop Line	Government	Hotel Jivan+Shop Line

S.NO.	PLOT NO.	AREA(m2)	TYPE OF PROPERTY	OWNERSHIP	REMARKS
6	BR2	468.00	Residential	Government	
7	KR1	2519.67	Commercial l+ Shop	Government	Wakhar+ Shiv Lodge
8	KR2	468.00	Open	Government	
9	FW1	2528.02	Open	Government	
10	FW2	468.00	Open	Government	
11	DP1	2527.05	Open	Government	
12	DP2	468.00	Commercial+Shop	Government	Shop Line
13	BP1	420.00	House Line	Government	House Line
14	BP2	420.00	House Line	Government	House Line
15	BP3	468.00	Open	Private	
16	KH1	420.00	Open	Government	
17	KH2	420.00	Open	Government	
18	KH3	468.00	Open	Private	
19	HR1	2626.83	Open	Government	
20	HR2	468.00	Open	Private	
21	SN1	364.90	Open	Government	Bus Stand
22	SN2	1095.37	Open	Government	Hospital
23	SN3	900.00	Open	Government	Police Station
24	SN4	148.60	Open	Government	
25	SN5	148.20	Commercial	Government	Bus Stand
26	SN6	68.90	Open	Government	Bus Stand
27	SN7	835.90	Open + commercial	Private	Pragati Surgical Medical Clinic. Land required for staton box construction.
28	SN8	582.60	Open	Government	Land required for station box construction.
29	ASI1	922.51	Open	Government	
30	ASI2	2830.70	Open	Government	
31	PMC1	3150.70	Open	Government	Petrol Pump+Primer Garage
32	PMC2	3946.00	Open	Government	
33	PMC3	61.90	Commercial	Government	
34	BH1	2376.20	Open	Government	
35	BH2	85.59	Open	Government	
36	MN1	3661.90	Open	Government	Shop Line+Police Station+House
37	MN2	32.70	Commercial	Pvt.	Shops
38	SW1	1008.60	Open	Private	Land required for station box construction.
39	SW2	141.90	Open	Private	

S.NO.	PLOT NO.	AREA(m ²)	TYPE OF PROPERTY	OWNERSHIP	REMARKS
40	SW3	3074.20	Open	Private	Land required for staton box construction.
41	SW4	457.70	Open	Private	
42	SW5	233.40	Open	Private	
Total		49746.86			
Corridor - II					
1	VN1	468.00	Open	Private	
2	VN2	420.00	Open	Private	
3	VN3	420.00	Open	Private	
4	AN1	468.00	Open	Private	
5	AN2	420.00	Residential	Private	
6	AN3	420.00	Residential	Private	
7	1C1	468.00	Open	Private	
8	1C2	420.00	Commercial	Private	
9	1C3	420.00	Commercial	Private	
10	NS1	468.00	Open	Private	
11	NS2	420.00	Commercial	Private	
12	NS3	420.00	Commercial	Private	
13	GC1	468.00	Open	Government	
14	GC2	420.00	Residential	Private	
15	GC3	420.00	Residential	Private	
16	DC1	468.00	Open	Private	
17	DC2	420.00	Open	Private	
18	DC3	420.00	Residential	Private	
19	ASI'1	468.00	Open	Private	
20	ASI'2	420.00	Commercial	Private	
21	ASI'3	420.00	Commercial	Private	
22	CC1	468.00	Open	Private	
23	CC2	420.00	Residential	Private	
24	CC3	420.00	Residential	Private	
25	MP1	468.00	Open	Private	
26	MP2	420.00	Open	Private	
27	MP3	420.00	Commercial	Private	
28	SN1	468.00	Open	Private	
29	SN2	420.00	Commercial	Government	
30	SN3	420.00	Commercial	Government	
31	PRS1	468.00	Commercial	Private	
32	PRS2	420.00	Commercial	Private	
33	PRS3	420.00	Commercial	Private	
34	RC1	468.00	Open	Private	

S.NO.	PLOT NO.	AREA(m2)	TYPE OF PROPERTY	OWNERSHIP	REMARKS
35	RC2	420.00	Open	Government	
36	RC3	420.00	Commercial	Private	
37	BG1	468.00	Shop	Private	
38	BG2	420.00	Residential	Private	
39	BG3	420.00	Residential	Private	
40	YD1	468.00	Residential	Private	
41	YD2	2520.00	Residential	Private	
42	KN1	468.00	Residential	Private	
43	KN2	2514.00	Residential	Private	
44	RV1	468.00	Open	Government	
45	RV2	420.00	Open	Government	
46	RV3	420.00	Open	Government	
Total		24282.00			

5.20.6 Land for Depot

A vacant land near Hill Range station in Agriculture University adjacent to the alignment of corridor 1 has been identified for locating a full fledged maintenance depot. The area identified is 115143.354 sq m or 11.51 Ha and is low lying from the surrounding road level. Earth filling is to be done to bring the existing ground level to designed level. The details of land requirement for depot are given in Table 5.19.

Table 5.19 - Land requirement for Depots

S N	Plot No.	Location	Land Area (Ha)	Ownership
1.	1DP1	Agriculture University Area(Corridor I)	11.51	Government
2.	2DP1	Kachara Depot land at Kothrud (Corridor I)	12.11	Government
Total			23.62	

5.20.7 Land for Receiving /Traction Sub Station

The details of land requirement for RSS / TSS are given in Table 5.20:

Table 5.20- Land Requirement for RSS/TSS

Corridor	Location	Land Area (Ha)	Ownership
Corridor 1 PimpriChinchwad -	Chinchwad (near PCMC office)	0.60	Government

Corridor	Location	Land Area (Ha)	Ownership
Swargate	Ganesh Khind (near Agricultural College)	0.60	Government
Corridor 2 Vanaz (Kothrud Depot) - Ramwadi	Kothrud (at Kachara Depot)	0.60	Government
	Kharadi (near Ramwadi)	0.60	Government
Total		2.4	

5.20.8 Land Requirement for Running Section

As indicated earlier, the ROW of the roads along which the alignment is planned is sufficiently wide hence no land is required for acquisition as long as the alignment is straight and at the center of the road. However, at curved portions, the alignment could not be kept at the center of the road and acquisition of certain land is inevitable in spite of introduction of sharper radius curves in elevated sections.

To the extent possible the Entry and Exit points of stations (underground and elevated) were planned on the foot paths. But, for locating other station facilities such as chiller plants, ventilation shafts, underground water tanks, generator set room etc., land acquisition is proposed. The land required for alignment planning is given in table 5.21.

Table 5.21- Land Requirement Running Section

S.NO.	PLOT NO.	LOCATION	DETAILS	AREA(m2)	OWNERSHIP
Corridor - I					
1	1RS 1	PCMC to SantTukaram Nagar	Open	136.3	Private
2	1RS 2	PCMC to SantTukaram Nagar	Open	194.7	Government
3	1RS 3	PCMC to SantTukaram Nagar	Open	309.9	Private
4	1RS 4	PCMC to SantTukaram Nagar	Open	201.6	Private
5	1RS 5	PCMC to SantTukaram Nagar	Commercial	85.6	Government
6	1RS 6	PCMC to SantTukaram Nagar	Commercial	59.4	Government
7	1RS 7	PCMC to SantTukaram Nagar	Open	17.8	Private
8	1RS 8	PCMC to SantTukaram Nagar	Residential	25.3	Private
9	1RS 9	PCMC to SantTukaram Nagar	Shop	23.7	Private
10	1RS 10	PCMC to SantTukaram Nagar	Open	13.8	Private
11	1RS 11	PCMC to SantTukaram Nagar	Residential	62	Private
12	1RS 12	PCMC to SantTukaram Nagar	Open	95.7	Private
13	1RS 13	PCMC to SantTukaram Nagar	Commercial	53.6	Private
14	1RS 14	PCMC to SantTukaram Nagar	Commercial	11	Government
15	1RS 15	PCMC to SantTukaram Nagar	Open	548.8	Private
16	1RS 16	PCMC to SantTukaram Nagar	Commercial	27.6	Private

S.NO.	PLOT NO.	LOCATION	DETAILS	AREA(m2)	OWNERSHIP
17	1RS 17	PCMC to Sant Tukaram Nagar	Residential	87.3	Private
18	1RS 18	PCMC to Sant Tukaram Nagar	Open	31	Private
19	1RS 19	PCMC to Sant Tukaram Nagar	Commercial	167	Private
20	1RS 20	PCMC to Sant Tukaram Nagar	Open	174.7	Private
21	1RS 21	PCMC to Sant Tukaram Nagar	Commercial	161	Private
22	1RS 22	PCMC to Sant Tukaram Nagar	Commercial	188.6	Private
23	1RS 23	PCMC to Sant Tukaram Nagar	Commercial	179.6	Private
24	1RS 24	PCMC to Sant Tukaram Nagar	Open	218.3	Private
25	1RS 25	PCMC to Sant Tukaram Nagar	Commercial	12.8	Private
26	1RS 26	PCMC to Sant Tukaram Nagar	Residential	160.1	Private
27	1RS 27	PCMC to Sant Tukaram Nagar	Open	393.3	Private
28	1RS 28	PCMC to Sant Tukaram Nagar	Office	4.7	Government
29	1RS 29	PCMC to Sant Tukaram Nagar	Office	19.9	Government
30	1RS 30	PCMC to Sant Tukaram Nagar	Residential	37.4	Private
31	1RS 31	PCMC to Sant Tukaram Nagar	Office	217.6	Government
32	1RS 32	PCMC to Sant Tukaram Nagar	Commercial	1852.8	Private
33	1RS 33	PCMC to Sant Tukaram Nagar	Office	11.1	Private
34	1RS 34	PCMC to Sant Tukaram Nagar	Open	302.7	Private
35	1RS 35	PCMC to Sant Tukaram Nagar	Office	4150	Government
36	1RS 36	PCMC to Sant Tukaram Nagar	Open	152.4	Private
37	1RS 37	PCMC to Sant Tukaram Nagar	Open	263.8	Private
38	1RS 38	PCMC to Sant Tukaram Nagar	Residential	78.3	Private
39	1RS 39	PCMC to Sant Tukaram Nagar	Open	16.7	Private
40	1RS 40	Sant Tukaram Nagar to Bhosari(Nashik Phata)	Open	221.6	Private
41	1RS 41	Sant Tukaram Nagar to Bhosari (Nashik Phata)	Office	8.8	Private
42	1RS 42	Sant Tukaram Nagar to Bhosari (Nashik Phata)	Commercial	4.3	Private
43	1RS 43	Sant Tukaram Nagar to Bhosari (Nashik Phata)	Open	718	Private
44	1RS 44	Sant Tukaram Nagar to Bhosari (Nashik Phata)	Open	254.1	Private
45	1RS 45	Sant Tukaram Nagar to Bhosari (Nashik Phata)	Commercial	33.2	Private
46	1RS 46	Sant Tukaram Nagar to Bhosari (Nashik Phata)	Open	63	Private
47	1RS 47	Sant Tukaram Nagar to Bhosari (Nashik Phata)	Open	1113.9	Private
48	1RS 48	Sant Tukaram Nagar to Bhosari (Nashik Phata)	Open	58.6	Private
49	1RS 49	Sant Tukaram Nagar to Bhosari (Nashik Phata)	Open	241.6	Private

S.NO.	PLOT NO.	LOCATION	DETAILS	AREA(m2)	OWNERSHIP
50	1RS 50	SantTukaram Nagar to Bhosari (Nashik Phata)	Open	68.4	Private
51	1RS 51	SantTukaram Nagar to Bhosari (Nashik Phata)	Open	120.9	Private
52	1RS 52	SantTukaram Nagar to Bhosari (Nashik Phata)	Commercial	43.6	Government
53	1RS 53	SantTukaram Nagar to Bhosari (Nashik Phata)	Open	240	Private
54	1RS 54	SantTukaram Nagar to Bhosari (Nashik Phata)	Commercial	24.8	Private
55	1RS 55	SantTukaram Nagar to Bhosari (Nashik Phata)	Open	17	Private
56	1RS 56	SantTukaram Nagar to Bhosari (Nashik Phata)	Commercial	71.8	Private
57	1RS 57	SantTukaram Nagar to Bhosari (Nashik Phata)	Shop	24.8	Private
58	1RS 58	Bhosari (Nashik Phata) to Kasarwadi	Open	373.5	Private
59	1RS 59	Bhosari(Nashik Phata) to Kasarwadi	Residential	24	Private
60	1RS 60	Bhosari(Nashik Phata) to Kasarwadi	Residential	12.5	Private
61	1RS 61	Bhosari(Nashik Phata) to Kasarwadi	Shop	12.6	Private
62	1RS 62	Bhosari(Nashik Phata) to Kasarwadi	Residential	58	Private
63	1RS 63	Bhosari(Nashik Phata) to Kasarwadi	Residential	10.1	Private
64	1RS 64	Bhosari(Nashik Phata) to Kasarwadi	Residential	1392.4	Private
65	1RS 65	Bhosari(Nashik Phata) to Kasarwadi	Residential	28.1	Private
66	1RS 66	Bhosari(Nashik Phata) to Kasarwadi	Residential	35.2	Private
67	1RS 67	Bhosari(Nashik Phata) to Kasarwadi	Residential	14.9	Private
68	1RS 68	Bhosari(Nashik Phata) to Kasarwadi	Residential	15.6	Private
69	1RS 69	Bhosari (Nashik Phata) to Kasarwadi	Shop	30.6	Private
70	1RS 70	Bhosari(Nashik Phata) to Kasarwadi	Shop	110.2	Private
71	1RS 71	Bhosari (Nashik Phata) to Kasarwadi	Residential	37.6	Private
72	1RS 72	Bhosari(Nashik Phata) to Kasarwadi	Residential	66.5	Private

S.NO.	PLOT NO.	LOCATION	DETAILS	AREA(m2)	OWNERSHIP
73	1RS 73	Bhosari (Nashik Phata) to Kasarwadi	Residential	23.2	Private
74	1RS 74	Bhosari(Nashik Phata) to Kasarwadi	Residential	111.1	Private
75	1RS 75	Bhosari(Nashik Phata) to Kasarwadi	Residential	1.4	Private
76	1RS 76	Bhosari(Nashik Phata) to Kasarwadi	Residential	30.3	Private
77	1RS 77	Bhosari(Nashik Phata) to Kasarwadi	Residential	64.1	Private
78	1RS 78	Bhosari(Nashik Phata) to Kasarwadi	Office	1249.2	Private
79	1RS 79	Bhosari(Nashik Phata) to Kasarwadi	Residential	0.9	Private
80	1RS 80	Bhosari(Nashik Phata) to Kasarwadi	Commercial	87.7	Private
81	1RS 81	Bhosari(Nashik Phata) to Kasarwadi	Office	250.5	Private
82	1RS 82	Kasarwadi to Fugewadi	Office	121.9	Private
83	1RS 83	Kasarwadi to Fugewadi	Shops	15.2	Private
84	1RS 84	Kasarwadi to Fugewadi	Office	321.9	Private
85	1RS 85	Kasarwadi to Fugewadi	Commercial	60.1	Private
86	1RS 86	Kasarwadi to Fugewadi	Office	766.8	Private
87	1RS 87	Kasarwadi to Fugewadi	Office	76.8	Private
88	1RS 88	Kasarwadi to Fugewadi	Commercial	47.3	Private
89	1RS 89	Kasarwadi to Fugewadi	Commercial	78.5	Private
90	1RS 90	Kasarwadi to Fugewadi	Residential	52.6	Private
91	1RS 91	Kasarwadi to Fugewadi	Residential	51.9	Private
92	1RS 92	Kasarwadi to Fugewadi	Residential	25.5	Private
93	1RS 93	Kasarwadi to Fugewadi	Residential	76.9	Private
94	1RS 94	Kasarwadi to Fugewadi	Commercial	26.8	Private
95	1RS 95	Kasarwadi to Fugewadi	Residential	223	Private
96	1RS 96	Kasarwadi to Fugewadi	Commercial	32.4	Private
97	1RS 97	Kasarwadi to Fugewadi	Residential	18.7	Private
98	1RS 98	Kasarwadi to Fugewadi	Commercial	37.3	Private
99	1RS 99	Kasarwadi to Fugewadi	Residential	13.7	Private
100	1RS 100	Kasarwadi to Fugewadi	Commercial	120	Government
101	1RS 101	Fugewadi to Dapodi	Office	1636	Private
102	1RS 102	Fugewadi to Dapodi	Office	657.3	Private
103	1RS 103	Fugewadi to Dapodi	Office	16366.3	Private
104	1RS 104	Dapodi to Bopodi	Office	10179.2	Private
105	1RS 105	Dapodi to Bopodi	Office	1527.8	Private

S.NO.	PLOT NO.	LOCATION	DETAILS	AREA(m2)	OWNERSHIP
106	1RS 106	Bopodi to Khadki	Office	47.7	Private
107	1RS 107	Bopodi to Khadki	Residential	9.6	Private
108	1RS 108	Bopodi to Khadki	Residential	4.9	Private
109	1RS 109	Bopodi to Khadki	Office	6.9	Private
110	1RS 110	Bopodi to Khadki	Residential	6.9	Private
111	1RS 111	Bopodi to Khadki	Office	211.4	Private
112	1RS 112	Khadki to RangeHill	Residential	43.4	Private
113	1RS 113	Khadki to RangeHill	Residential	11.9	Government
114	1RS 114	Khadki to RangeHill	Residential	40.3	Government
115	1RS 115	Khadki to RangeHill	Shops	28.1	Private
116	1RS 116	Khadki to RangeHill	Office	69.3	Private
117	1RS 117	Khadki to RangeHill	Residential	18.1	Private
118	1RS 118	Khadki to RangeHill	Residential	40.2	Government
119	1RS 119	Khadki to RangeHill	Office	37.5	Private
120	1RS 120	Khadki to RangeHill	Office	186.4	Private
121	1RS 121	Khadki to RangeHill	Office	10554.5	Private
122	1RS 122	Khadki to RangeHill	Office	465.2	Private
123	1RS 123	Khadki to RangeHill	Office	271.6	Private
124	1RS 124	Khadki to RangeHill	Office	2581.3	Private
125	1RS 125	Khadki to RangeHill	Office	3523	Private
126	1RS 126	Khadki to RangeHill	Office	1891.4	Private
127	1RS 127	Khadki to RangeHill	Office	219.6	Private
128	1RS 128	Khadki to RangeHill	Office	297.6	Private
129	1RS 129	Range Hill to Shivaji Nagar	Office	1931.6	Private
130	1RS 130	Range Hill to Shivaji Nagar	Office	7092	Private
131	1RS 131	Range Hill to Shivaji Nagar	Office	1013.9	Private
			TOTAL	81254.7	
Corridor - II					
1	2RS 1	Anand Nagar to Ideal Colony	Open	44.4	Private
2	2RS 2	Anand Nagar to Ideal Colony	Open	80.9	Government
3	2RS 3	Anand Nagar to Ideal Colony	Open	8.5	Private
4	2RS 4	Ideal Colony to Nal Stop	Open	50.4	Private
5	2RS 5	Ideal Colony to Nal Stop	Commercial	10.1	Government
6	2RS 6	Ideal Colony to Nal Stop	Commercial	96.1	Government
7	2RS 7	Ideal Colony to Nal Stop	Open	39.7	Private
8	2RS 8	Ideal Colony to Nal Stop	Residential	4.7	Private
9	2RS 9	Ideal Colony to Nal Stop	Shop	86.2	Private
10	2RS 10	Ideal Colony to Nal Stop	Open	18.7	Private
11	2RS 11	Ideal Colony to Nal Stop	Residential	17.8	Private
12	2RS 12	Ideal Colony to Nal Stop	Open	308	Private

S.NO.	PLOT NO.	LOCATION	DETAILS	AREA(m2)	OWNERSHIP
13	2RS 13	Garware College to Deccan	Commercial	121.7	Private
14	2RS 14	Garware College to Deccan	Commercial	161.6	Government
15	2RS 15	Garware College to Deccan	Open	12.4	Private
16	2RS 16	Garware College to Deccan	Commercial	91.7	Private
17	2RS 17	Garware College to Deccan*	Residential	232.2	Private
18	2RS 18	ASI to Civil Court*	Open	2600.1	Private
19	2RS 19	ASI to Civil Court*	Commercial	156.2	Private
20	2RS 20	ASI to Civil Court*	Open	681.1	Private
21	2RS 21	Civil Court to Mangalwar Peth	Commercial	249.2	Private
22	2RS 22	Civil Court to Mangalwar Peth	Commercial	383.3	Private
23	2RS 23	Civil Court to Mangalwar Peth	Commercial	2961.5	Private
24	2RS 24	Civil Court to Mangalwar Peth	Open	53.1	Private
25	2RS 25	Civil Court to Mangalwar Peth	Commercial	2908.4	Private
26	2RS 26	Civil Court to Mangalwar Peth	Residential	1344.8	Private
27	2RS 27	Mangalwar Peth to Sasson	Open	876.3	Private
28	2RS 28	Mangalwar Peth to Sasson	Office	18.6	Government
29	2RS 29	Sasson to Pune R. Station	Office	78.6	Government
30	2RS 30	Sasson to Pune R. Station	Residential	114.2	Private
31	2RS 31	Pune R. Station to Ruby Clinic	Office	768.3	Government
32	2RS 32	Pune R. Station to Ruby Clinic	Commercial	250	Private
33	2RS 33	Pune R. Station to Ruby Clinic	Office	40.1	Private
34	2RS 34	Pune R. Station to Ruby Clinic	Open	110.7	Private
35	2RS 35	Ruby Clinic to Bund Garden	Office	71.9	Government
36	2RS 36	Bund Garden to Yerawada	Open	2656.7	Private
37	2RS 37	Bund Garden to Yerawada	Open	71.6	Private
38	2RS 38	Bund Garden to Yerawada	Residential	43.8	Private
39	2RS 39	Bund Garden to Yerawada	Residential	23.1	Private
40	2RS 40	Bund Garden to Yerawada	Shops	8.9	Private
41	2RS 41	Bund Garden to Yerawada	Residential	2609.1	Private
42	2RS 42	Yerawada to Kalyani Nagar	Open	303.8	Private
43	2RS 43	Yerawada to Kalyani Nagar	Open	20.9	Private
44	2RS 44	Yerawada to Kalyani Nagar	Shops	35.6	Private
45	2RS 45	Yerawada to Kalyani Nagar	Shops	31.4	Private
46	2RS 46	Yerawada to Kalyani Nagar	Office	4402.6	Government
47	2RS 47	Yerawada to Kalyani Nagar	Office	12.7	Government
48	2RS 48	Yerawada to Kalyani Nagar	Shops	14.1	Private
49	2RS 49	Yerawada to Kalyani Nagar	Shops	33.7	Private
			TOTAL	25319.5	

*Between Garware college & City civil court 3 stations proposed (Deccan, Sambhaji park & PMC)

5.20.9 Land for Construction Depot

4pockets of land two on each corridor have been identified for locating Construction Depot. The total area identified is about 9.5Ha. These land pockets will be acquired on temporary basis during construction period. The details of land requirement for depot are given in Table 5.22.

Table 5.22 -Land Requirement on Temporary Basis for Construction Depot

S.No	Location	Land Area(Ha)	Ownership
Corridor- I			
1	PCMC	4.0	Pvt.
2	Range Hill	4.0	Pvt.
3	Swargate	1.0	Pvt.
Corridor- II			
	Ramwadi	0.50	
Total		9.5	

5.21 LAND REQUIRED FOR PROPERTY DEVELOPMENT

Identification of Sites for Property Development:

To ensure fast implementation of the proposals and optimisation of earnings, the following criteria have been kept in view:

- Land plots to be close to the proposed MRTS corridor.
- Land plots should be vacant and owned preferably by a Government agency.
- Proposed usage to be in conformity with provisions of Development Plans of the city.
- Availability of adequate infrastructural support and optimum potential for commercial utilization and early high returns.

Methodology of Property Development:

Process of property development requires land, labour, capital, entrepreneurship and management as major inputs. Following steps are involved in the process:

- To obtain land free from all encumbrances with a clear title.
- To obtain clearances of the concerned government and local authorities for proposed usage, ground coverage, FAR, height and other basic controls and availability of essential services like water supply, sewers, electric supply, approach roads, etc.

- To assess demand and optimum usage and expected returns.
- To prepare architectural plans/models and obtain sanctions of concerned authorities.
- To prepare construction plans, structural designs, etc. for implementation.
- To appoint executing agency and create supervising organization.
- To sell the developed property and realize the proceeds thereof.
- To allow the property on long-term lease.

Property development and its transfer can be under taken by MRTS either by themselves or in collaboration with a builder/developer. Since it involves not only heavy financial investment but also real estate expertise and risk, it is considered better to undertake this activity in collaboration with some established builder/developer of repute on pre-agreed terms regarding individual responsibilities and various related financial aspects.

The details of land identified for property development are shown in Table 5.23 below. The property development shall be taken either by BOT operator or private agency.

Table 5.23 -Land identified for Property Development

S. No	Location	Survey No.	Land Area (Sqm)	Ownership
1.	Kharadi	61/1/1/2,61/2	6812	Private
2.	Kharadi	60/1/2	7114	Private
3.	Wadgaon Sheri	59/1+2+3/1, 1+2+3/2	17237	Private
4.	Kondhawa kh	63/1/3A + 1/4 + 1/5 + 1/6 + 1/7 p	5668	Private
5.	Kondhawa bk	18/2/5, 18/2/6, 19/18, 19/19 Ao	6730	Private
6.	Baner	221 to 223	5143	Private
7.	Balewadi	14 + 15	5731	Private
8.	Swargate	-	10000	Irrigation Department
Total =			64435	

5.22 SUMMARY OF LAND REQUIREMENTS

Abstract of land requirements for Corridor -1 and Corridor-2 is given in Table 5.24:

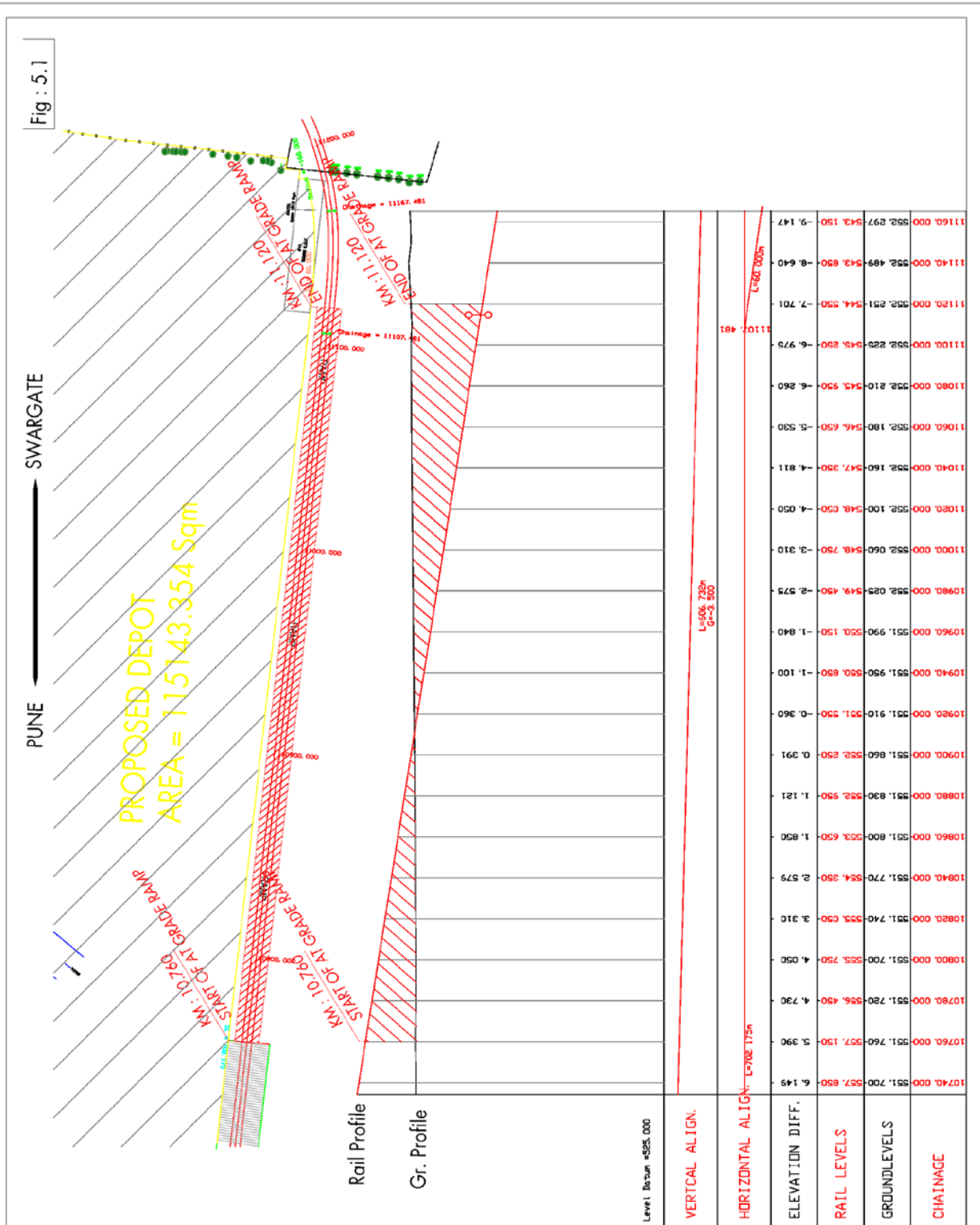
Table 5.24- Summary of Permanent Land Requirement (Ha)

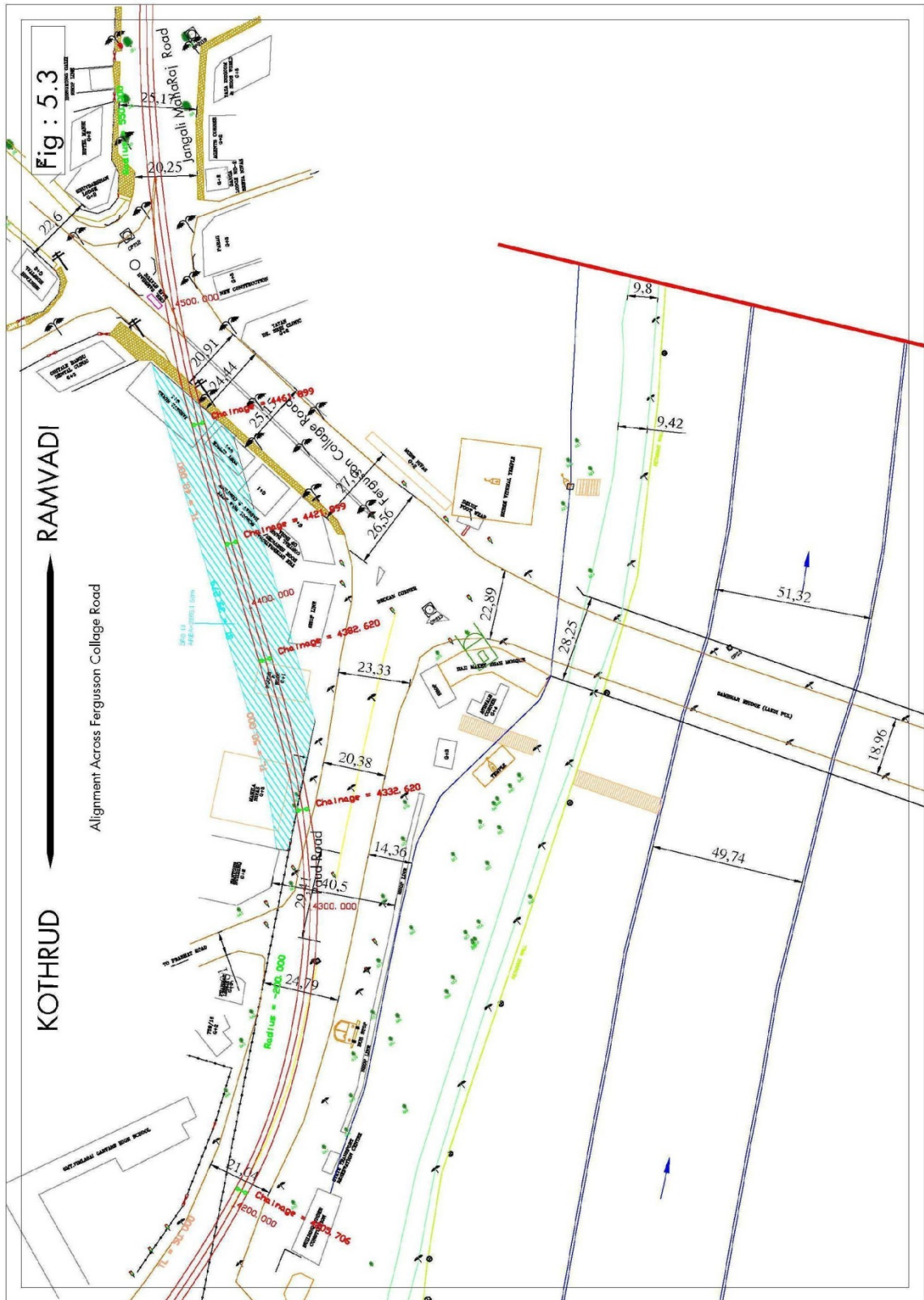
SN	Description	Corr I			Corr II		
		Govt.	Pvt.		Govt.	Pvt.	
			Comm.	Res.		Comm.	Res.
1.	Stations	4.2	--	0.80	0.30	0.60	1.53
2.	Running Section	0.50	6.80	0.80	0.55	0.980	1.17
3.	RSS/TSS	1.20	--	--	1.20	--	--
4.	Depots	11.51	--	--	12.11	--	--
	Total	17.41	6.80	1.60	14.16	1.58	2.70

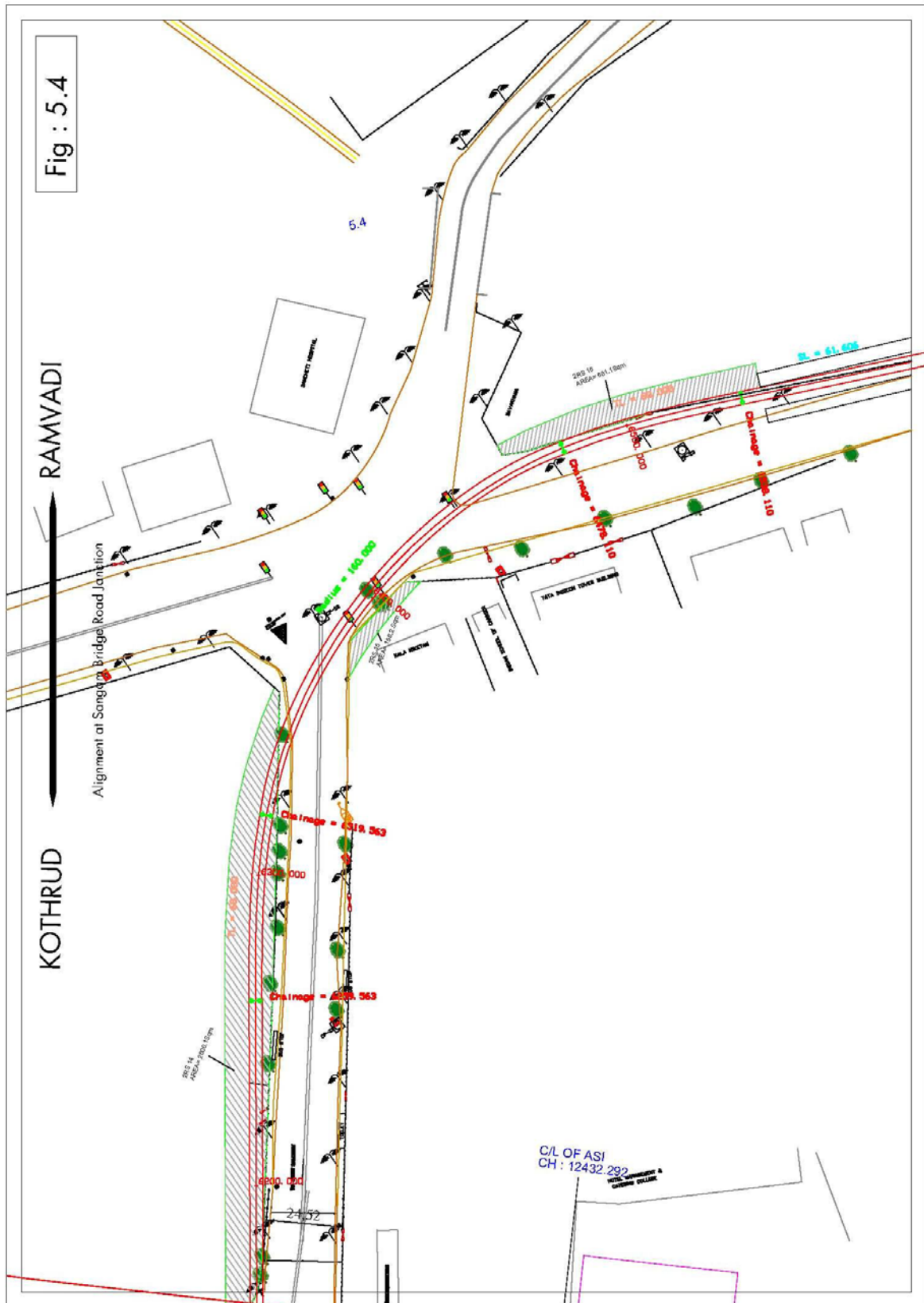
Total Land required for both corridors: 31.57Ha (Govt.) + 12.68Ha (Pvt.) = **44.25 Ha**.

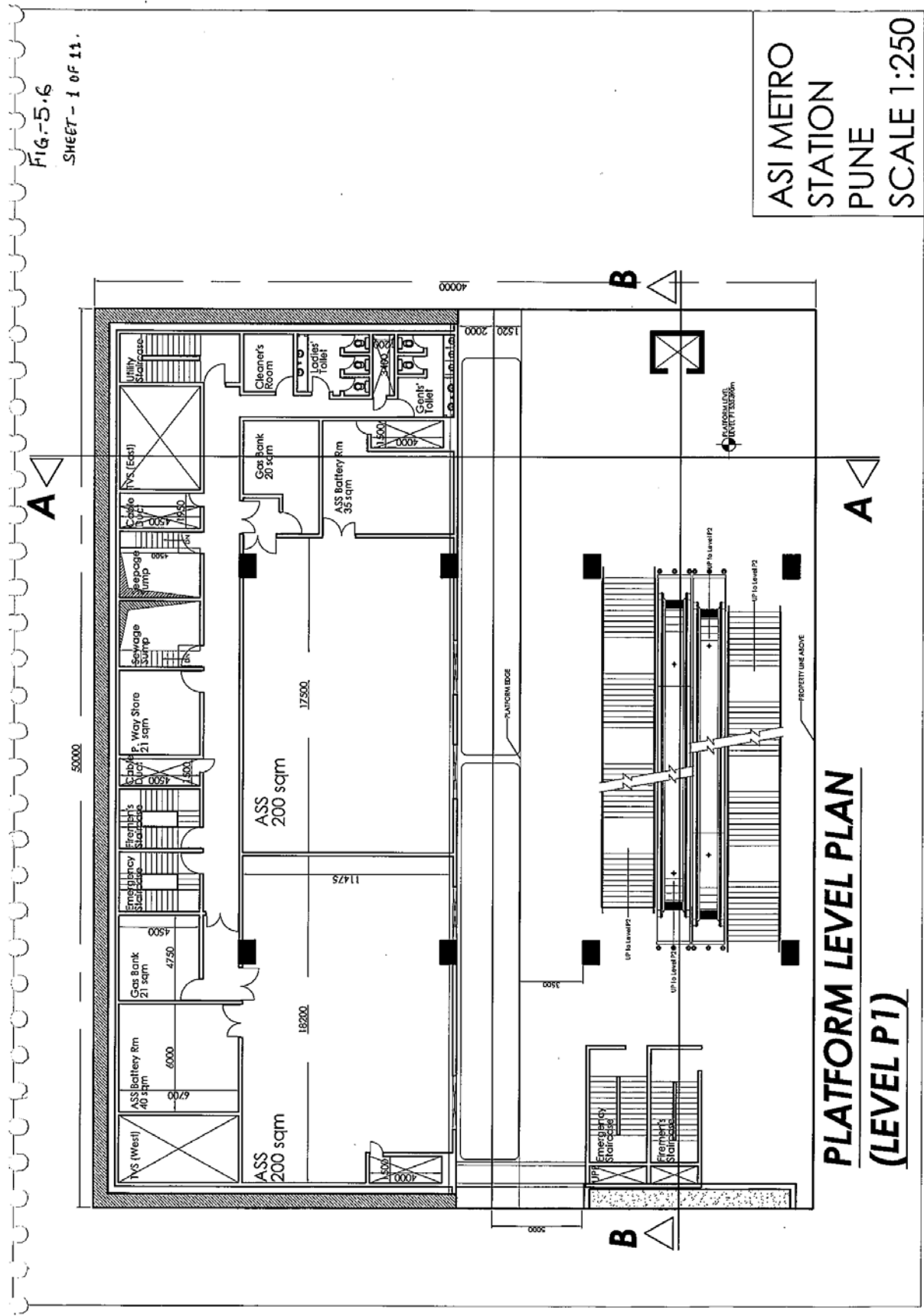
5.23 Relocation / Resettlement

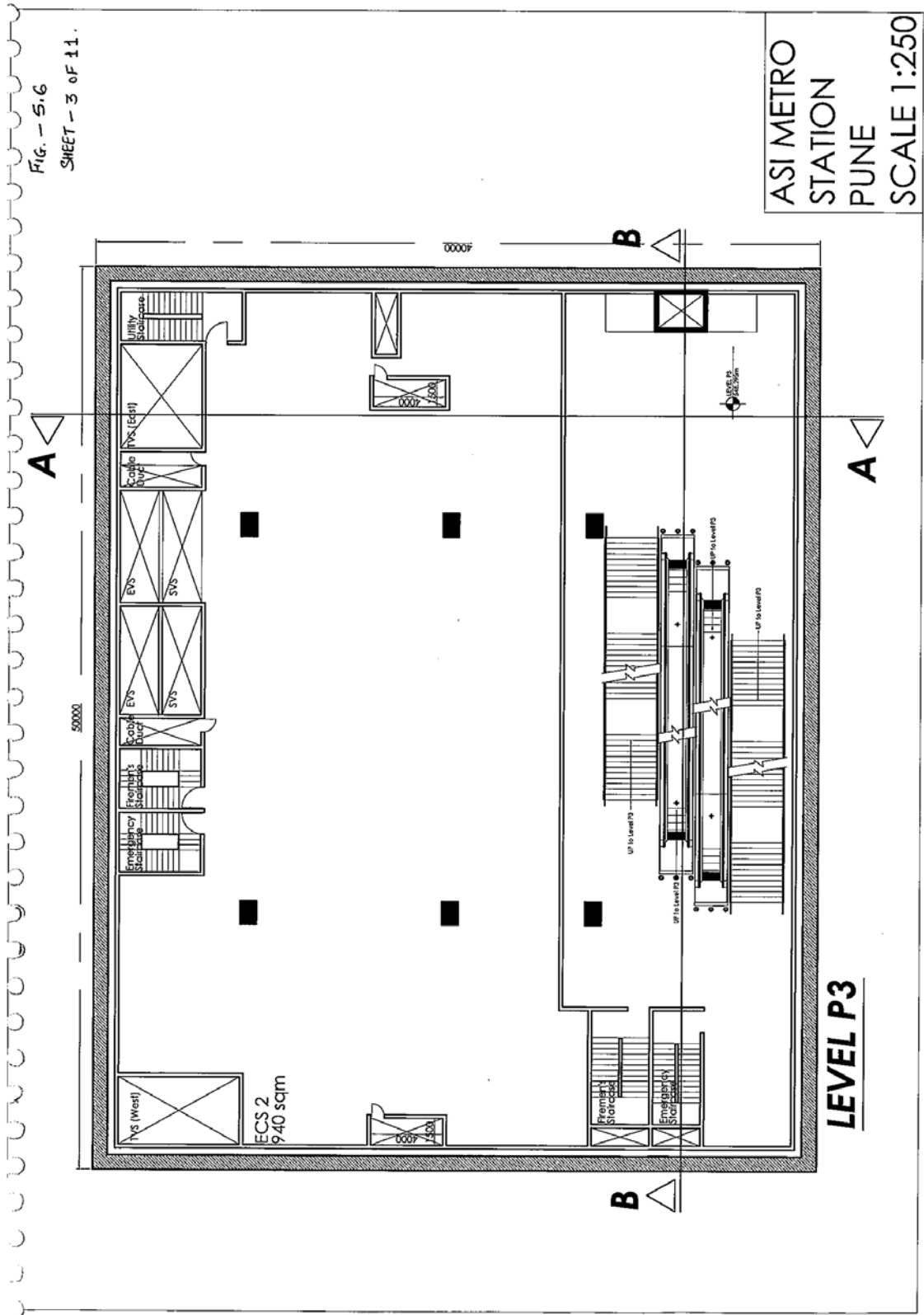
The project involves relocation of few shops, commercial cum residential buildings and hutments along the alignment. Compensation for relocation of these affected structures shall be paid and it has been considered in the project cost estimate. The alignment has been so chosen, that it remains mostly within the government land. However, at certain locations while negotiating the curves, the land acquisition became inevitable. It is proposed to invite bids from private developers to offer constructed tenements against TDR and cash components in their own land.

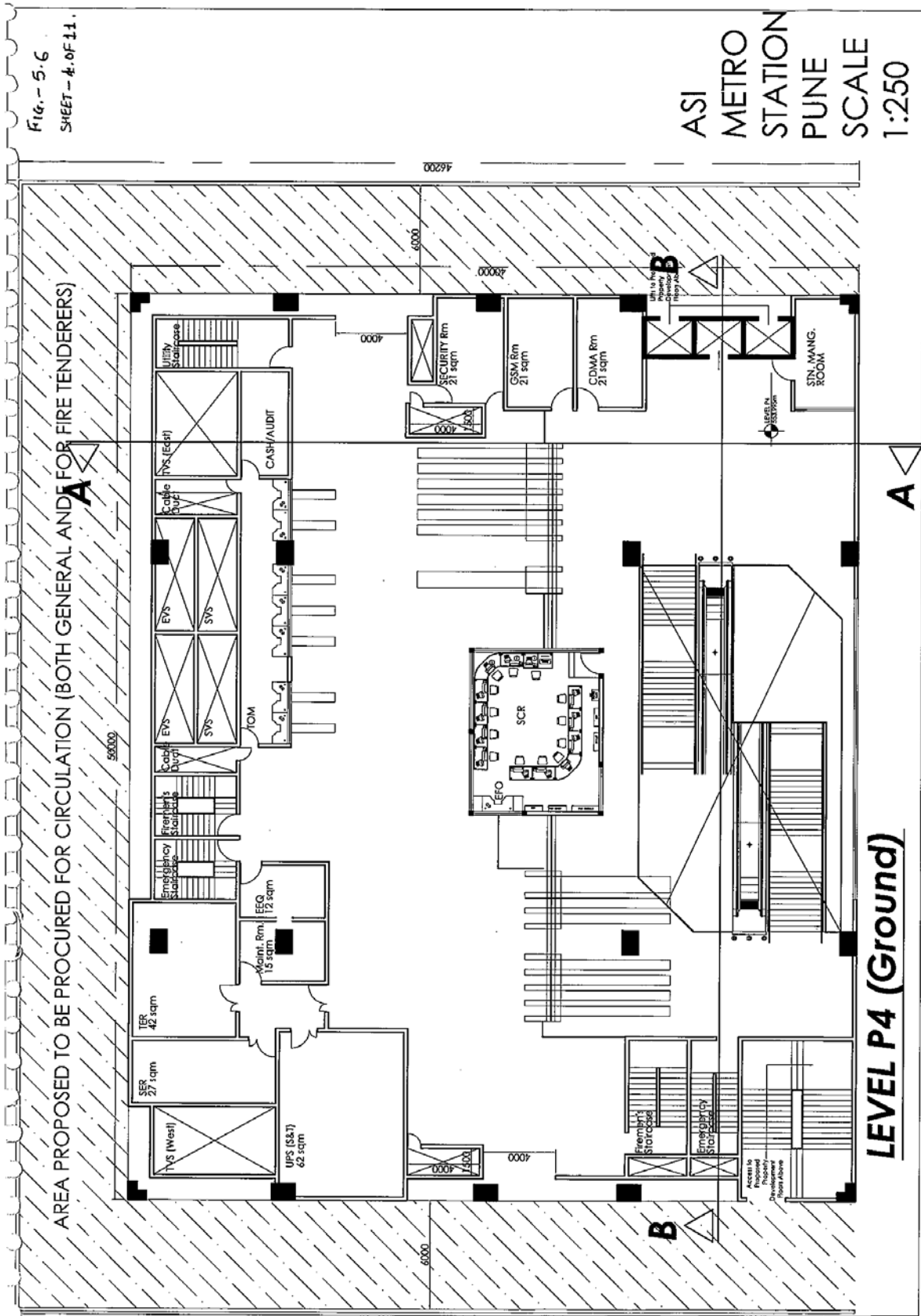


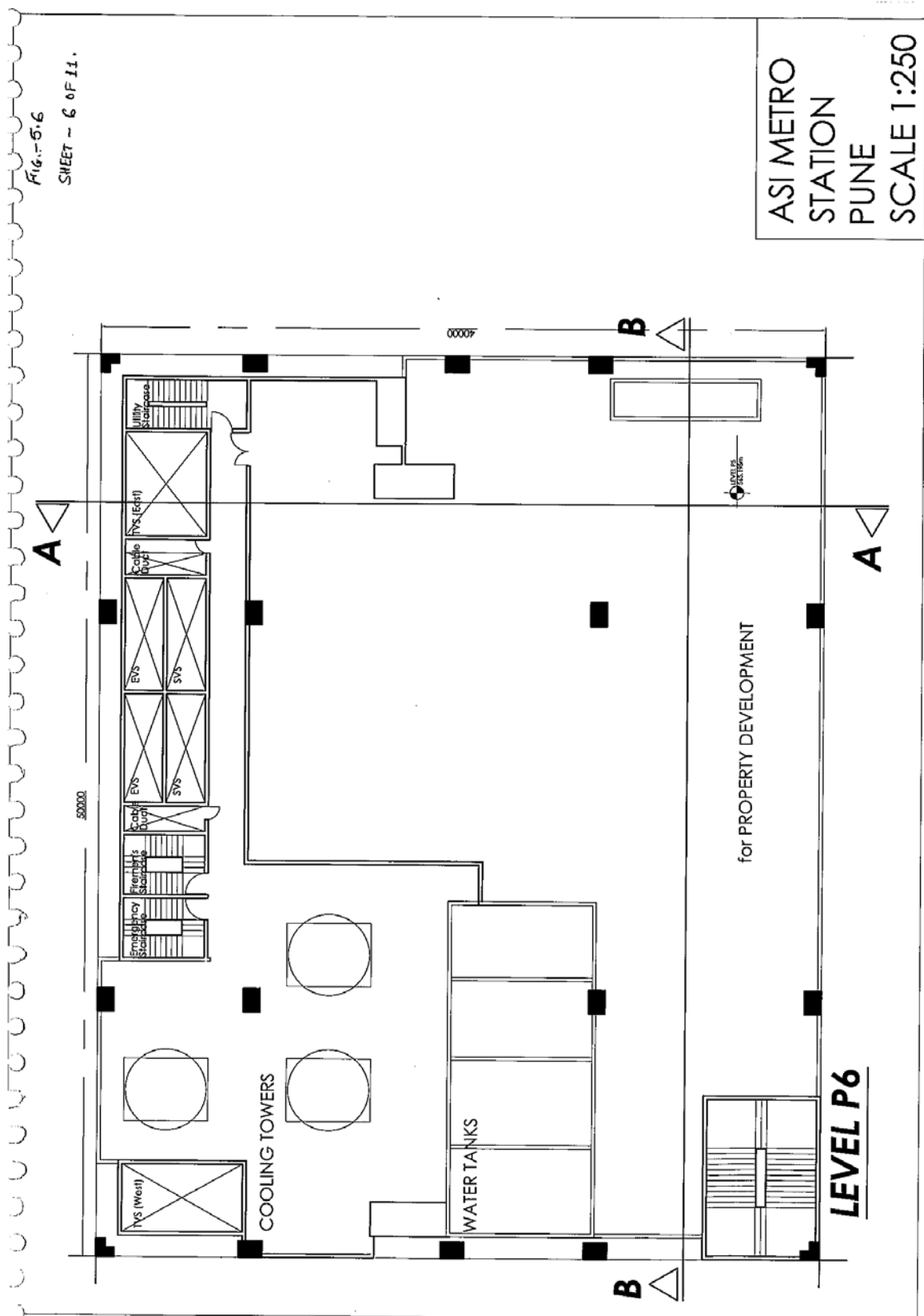


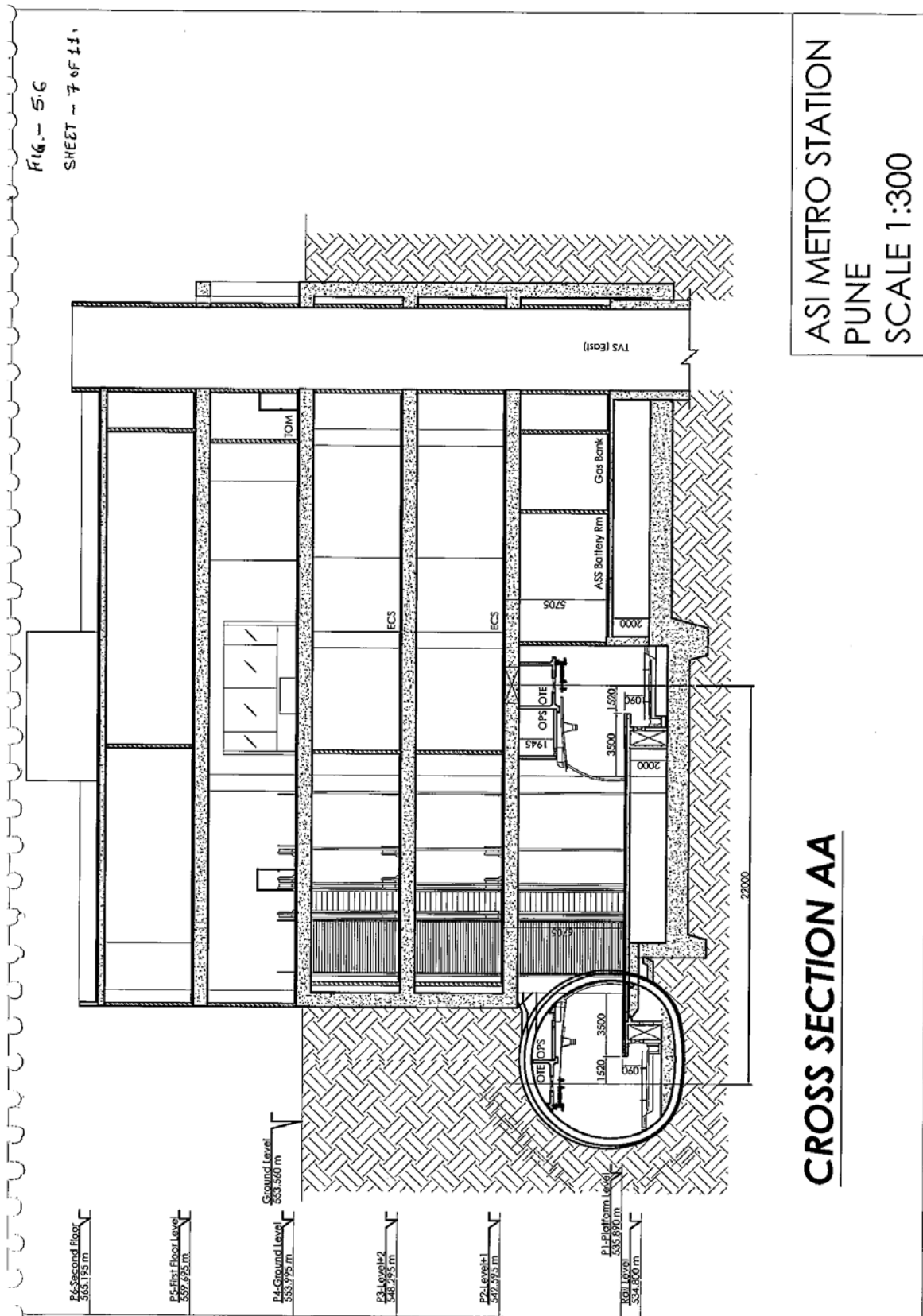












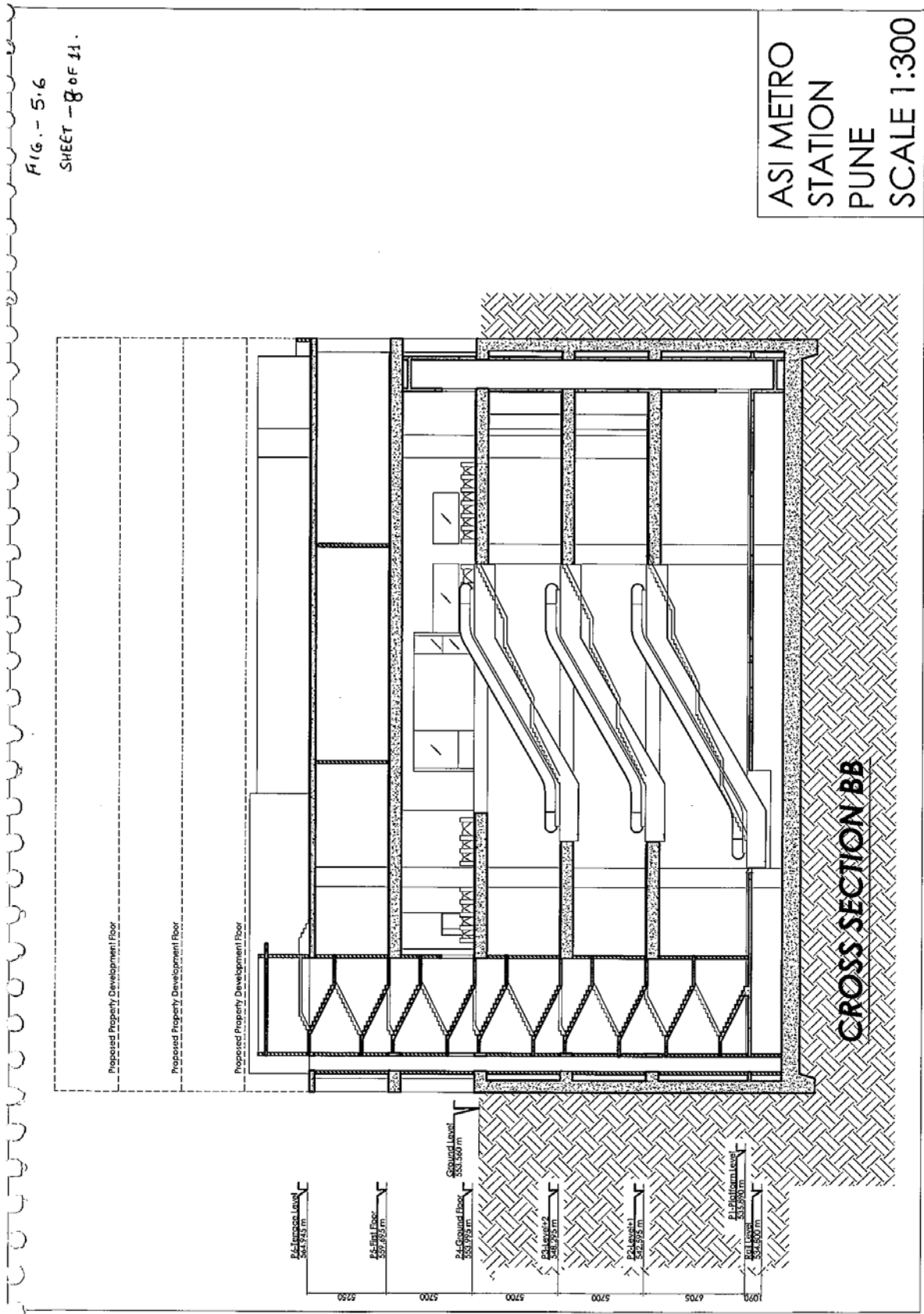
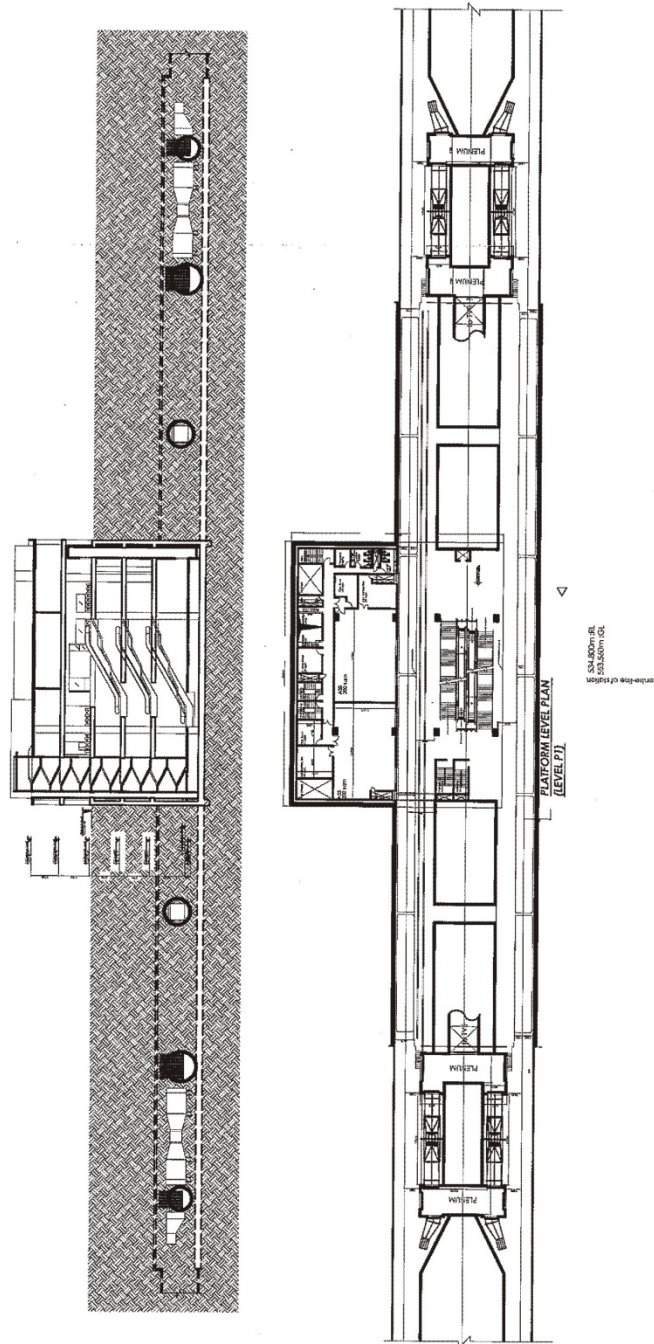
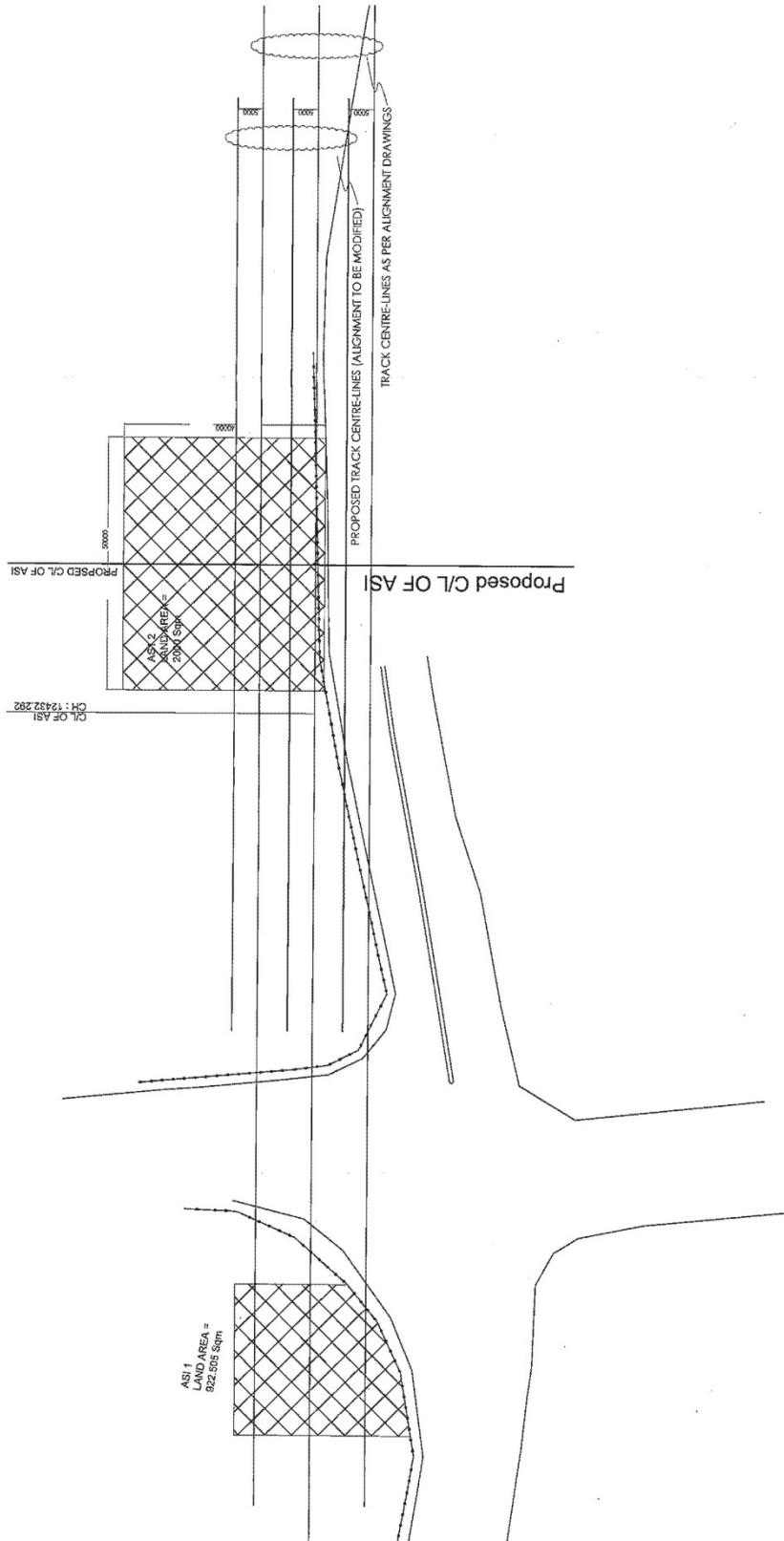


Fig. - 5.6
sheet - 9 of 11

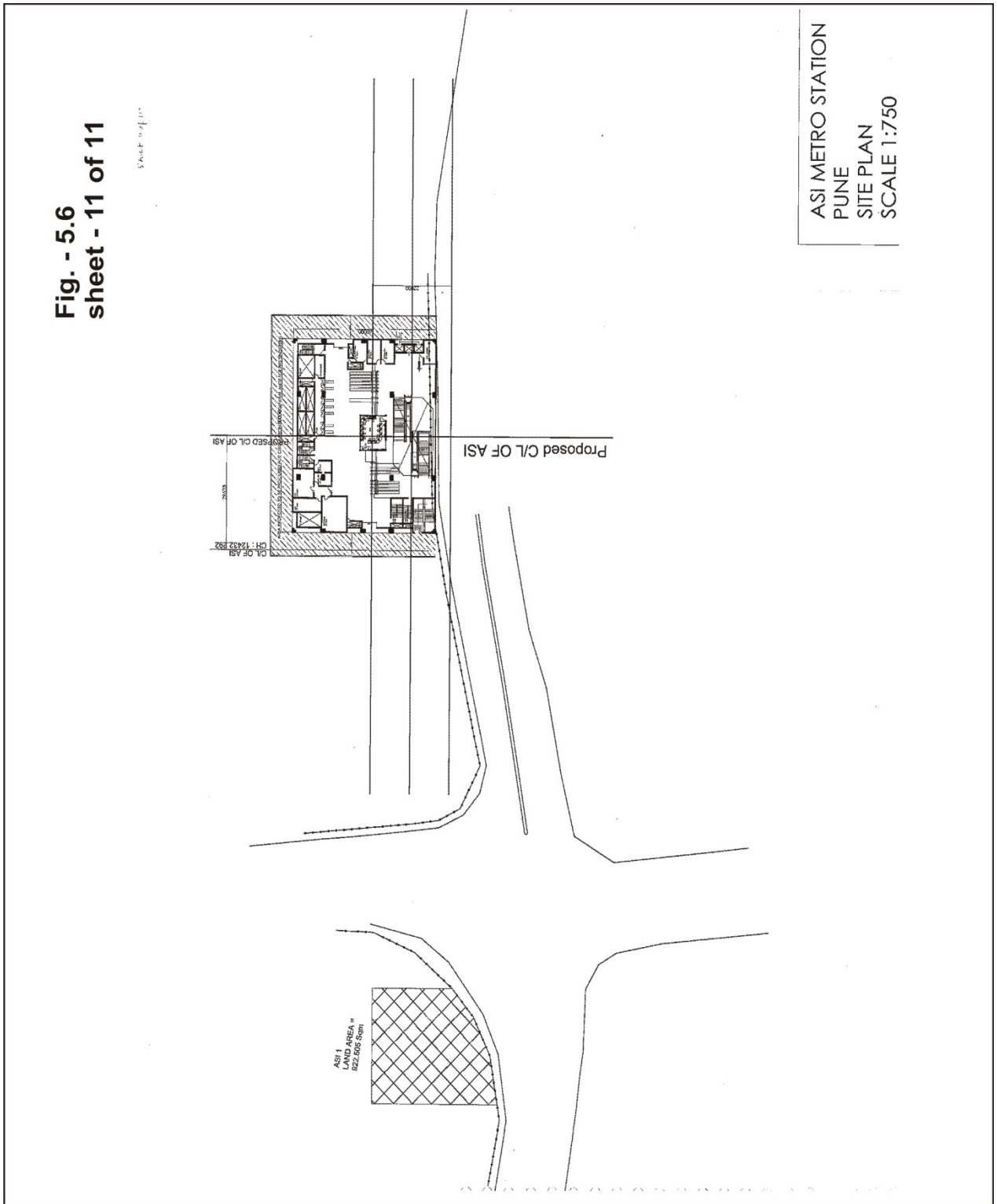


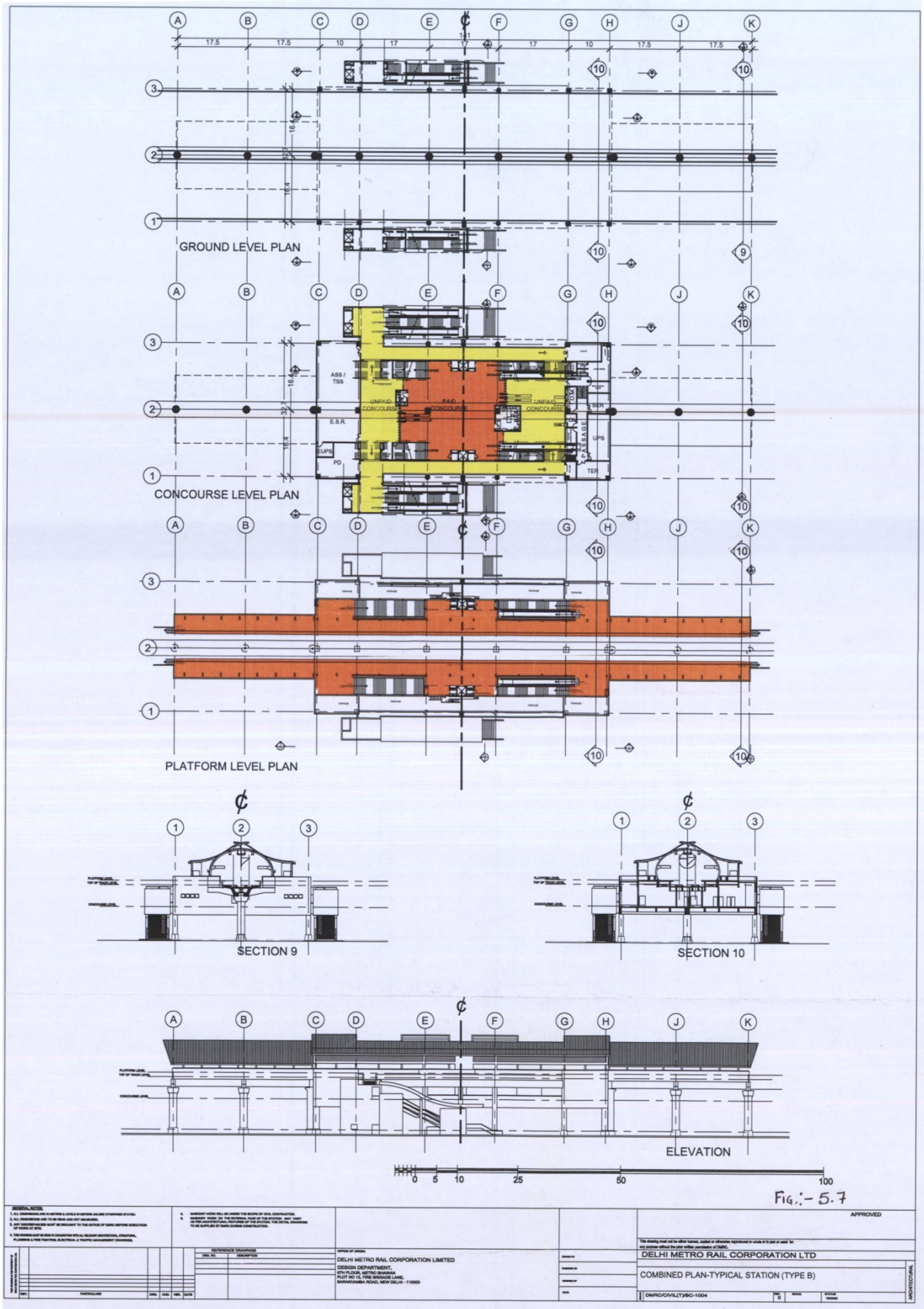
ASI METRO STATION
PUNE
LONGITUDINAL SECTION
SCALE 1:750

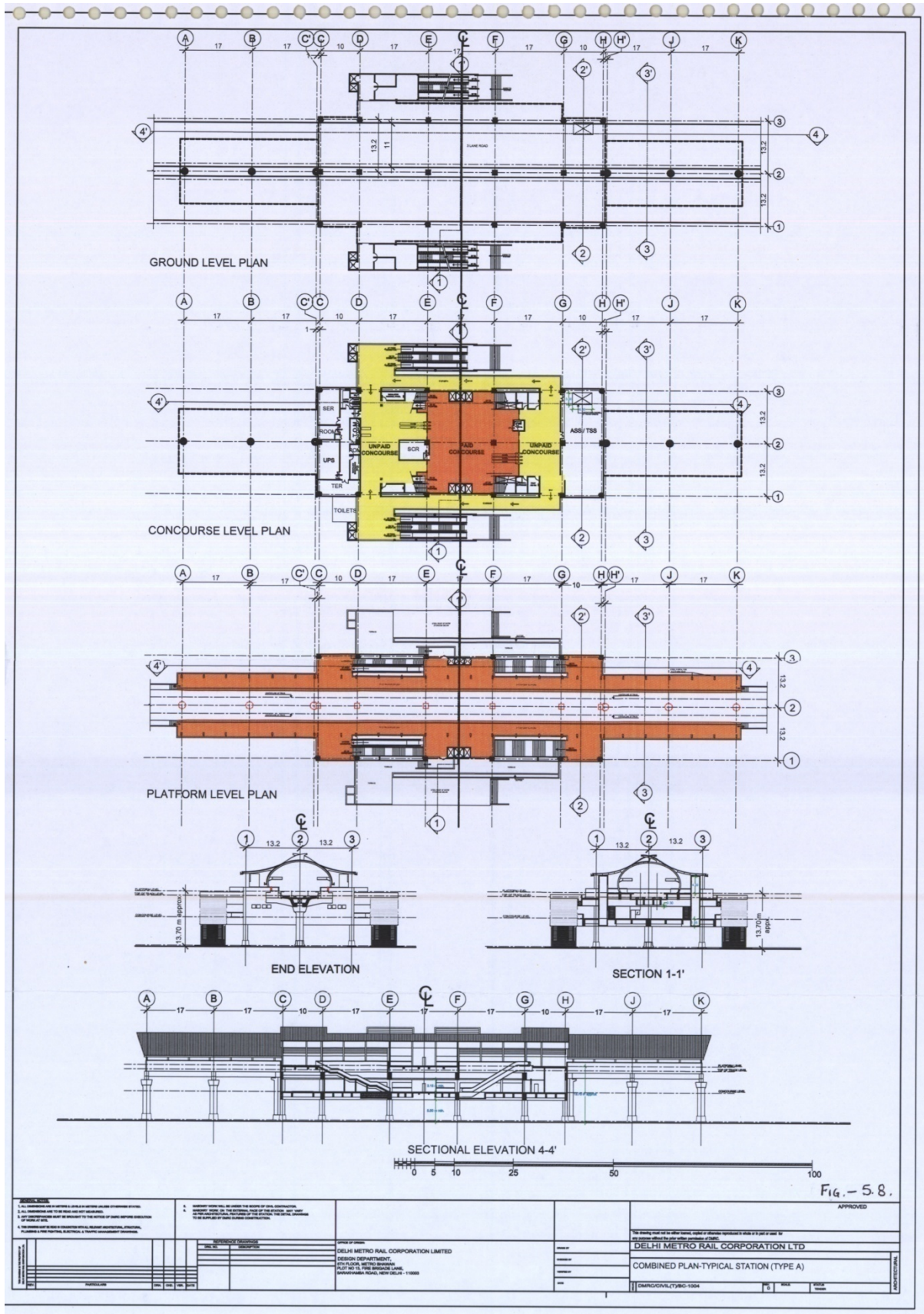
Fig. - 5.6
sheet - 10 of 11

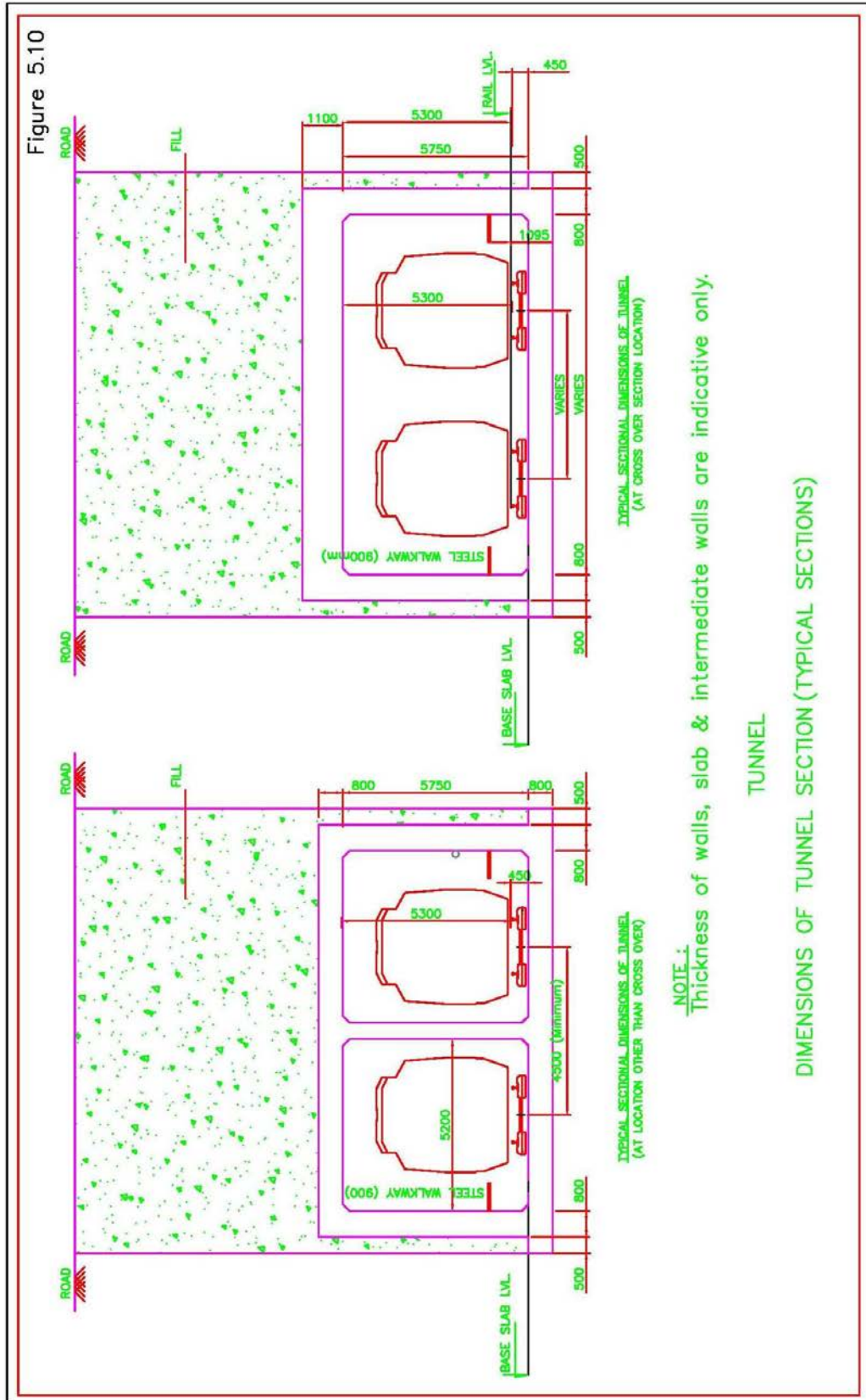


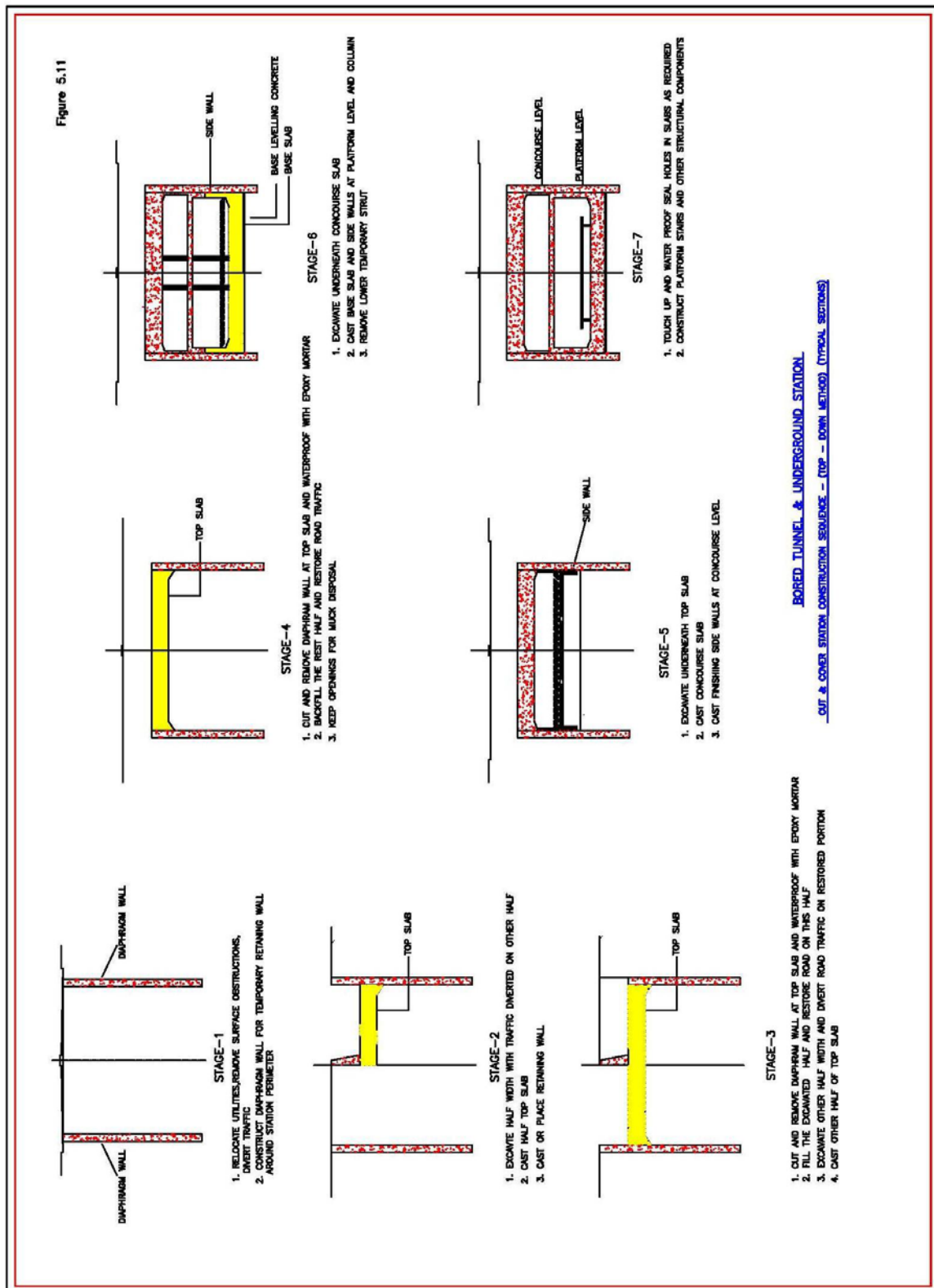
ASI METRO STATION
PUNE
LAND PLAN
SCALE 1:750











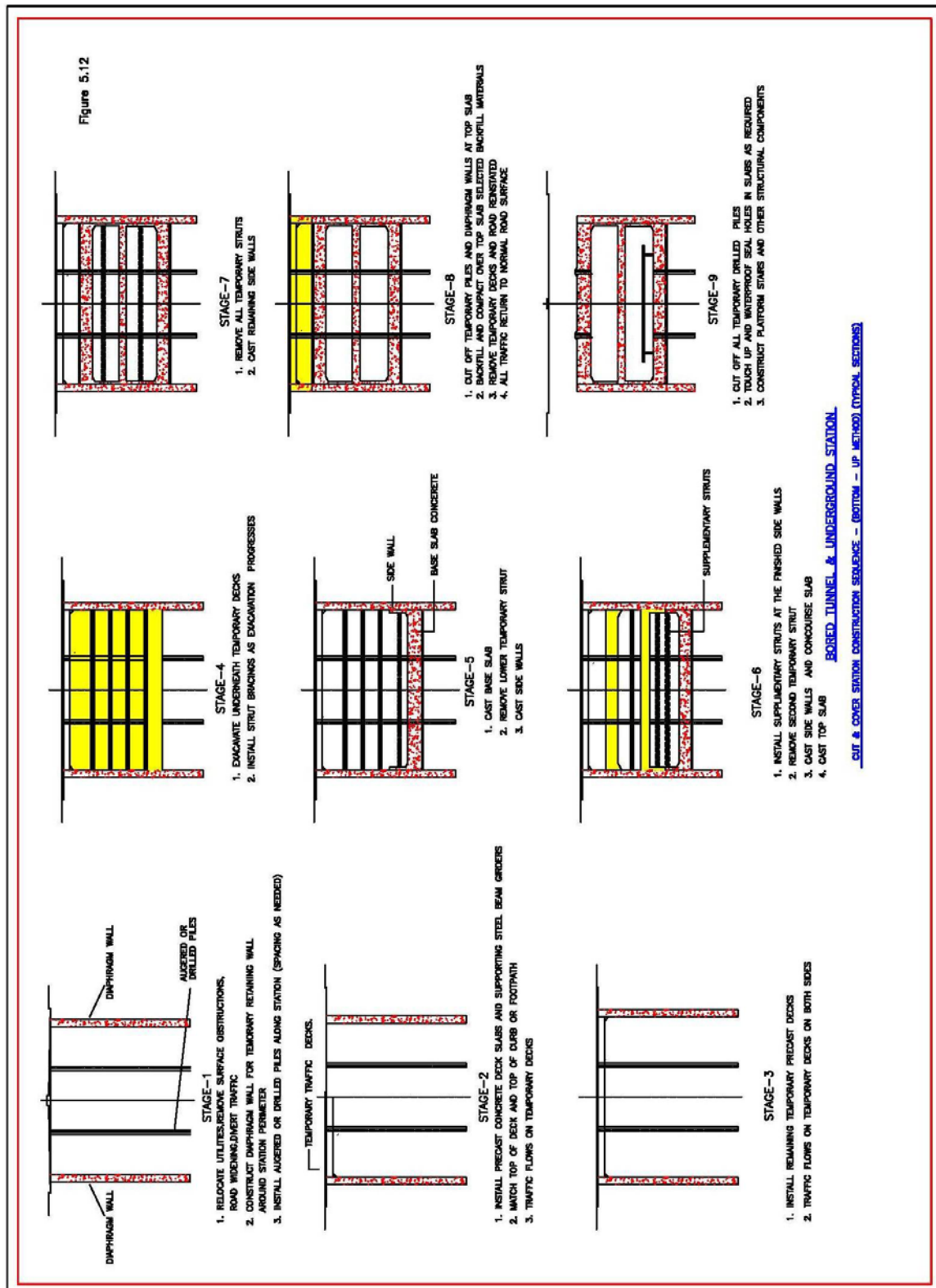
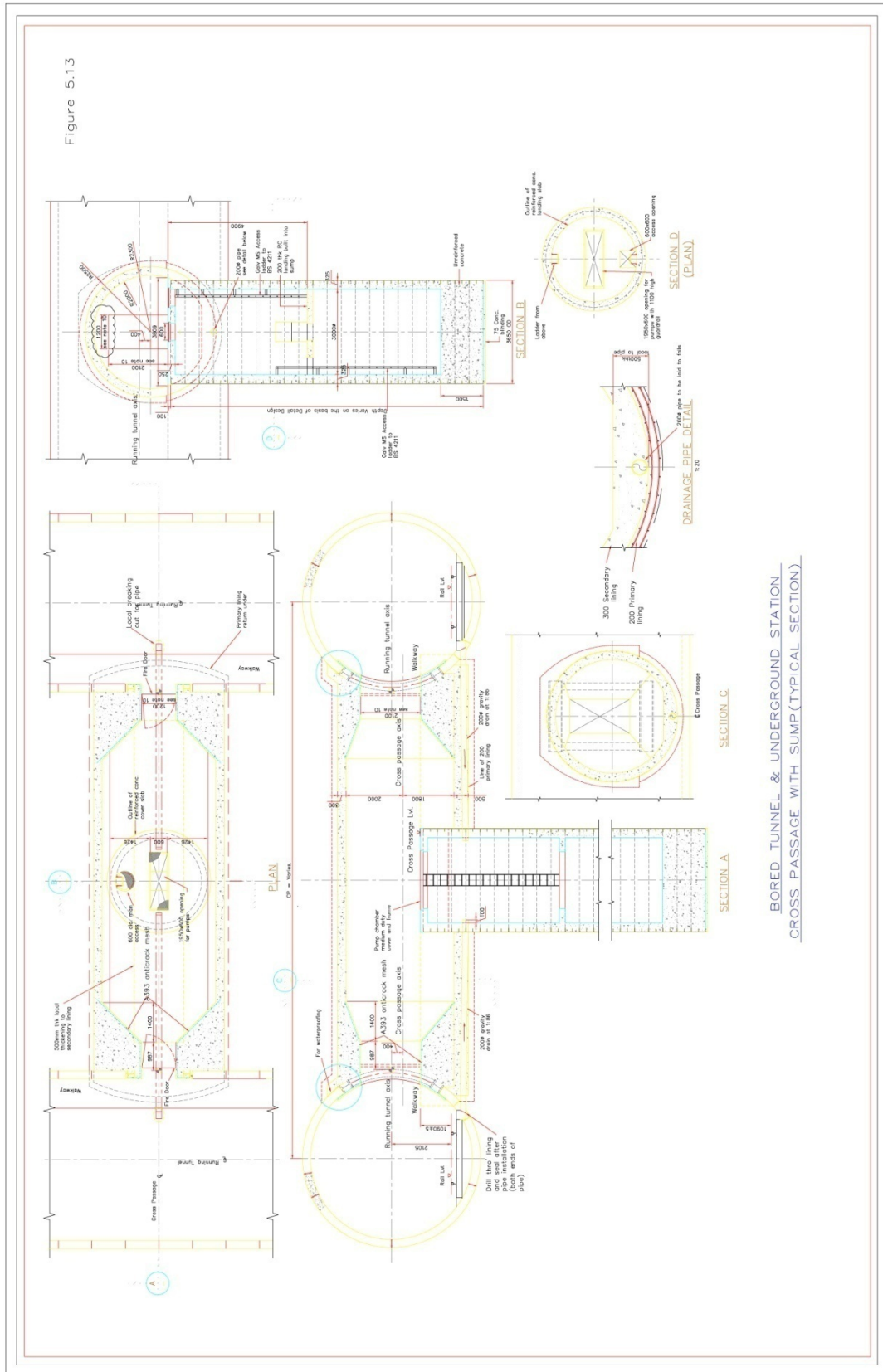
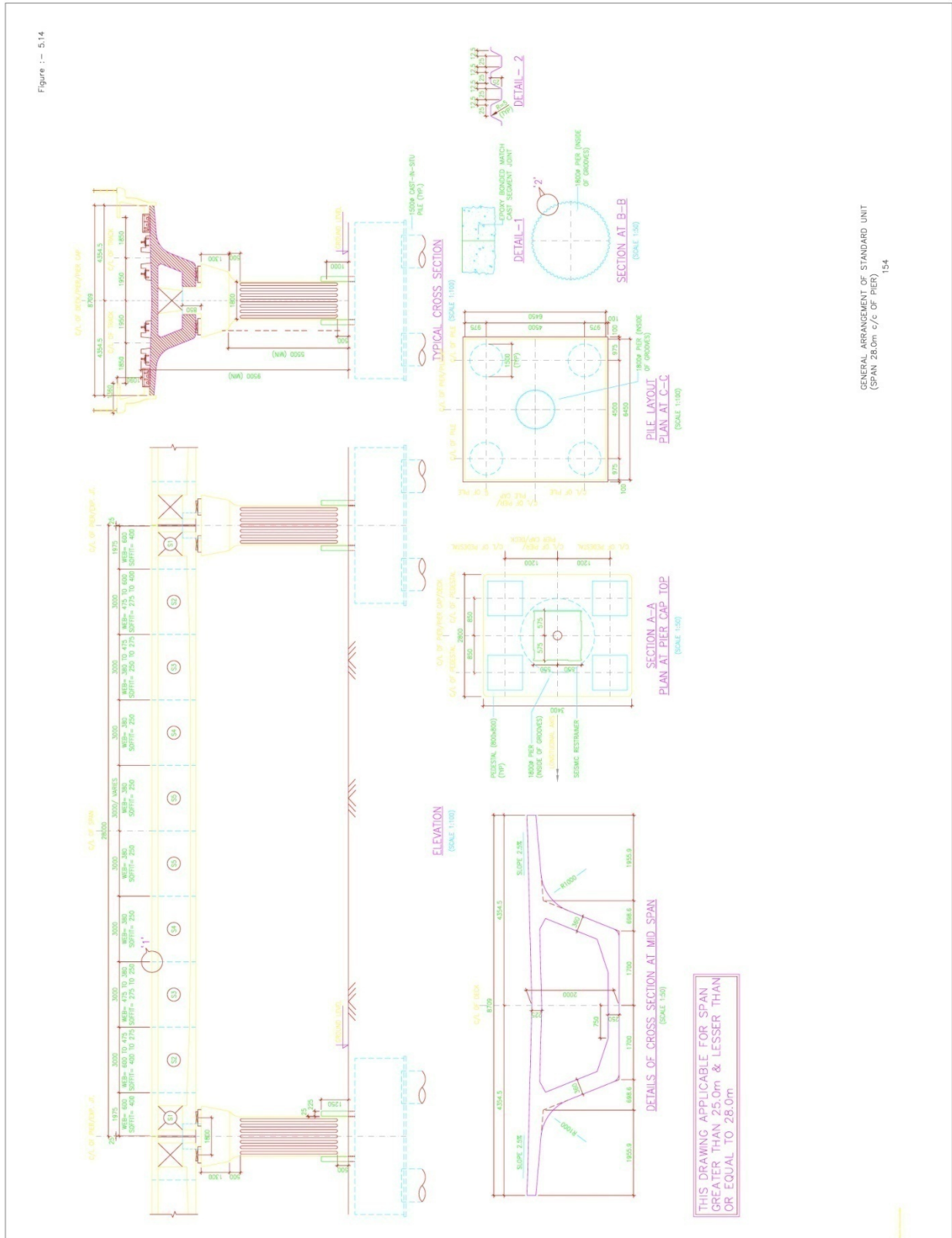


Figure 5.13

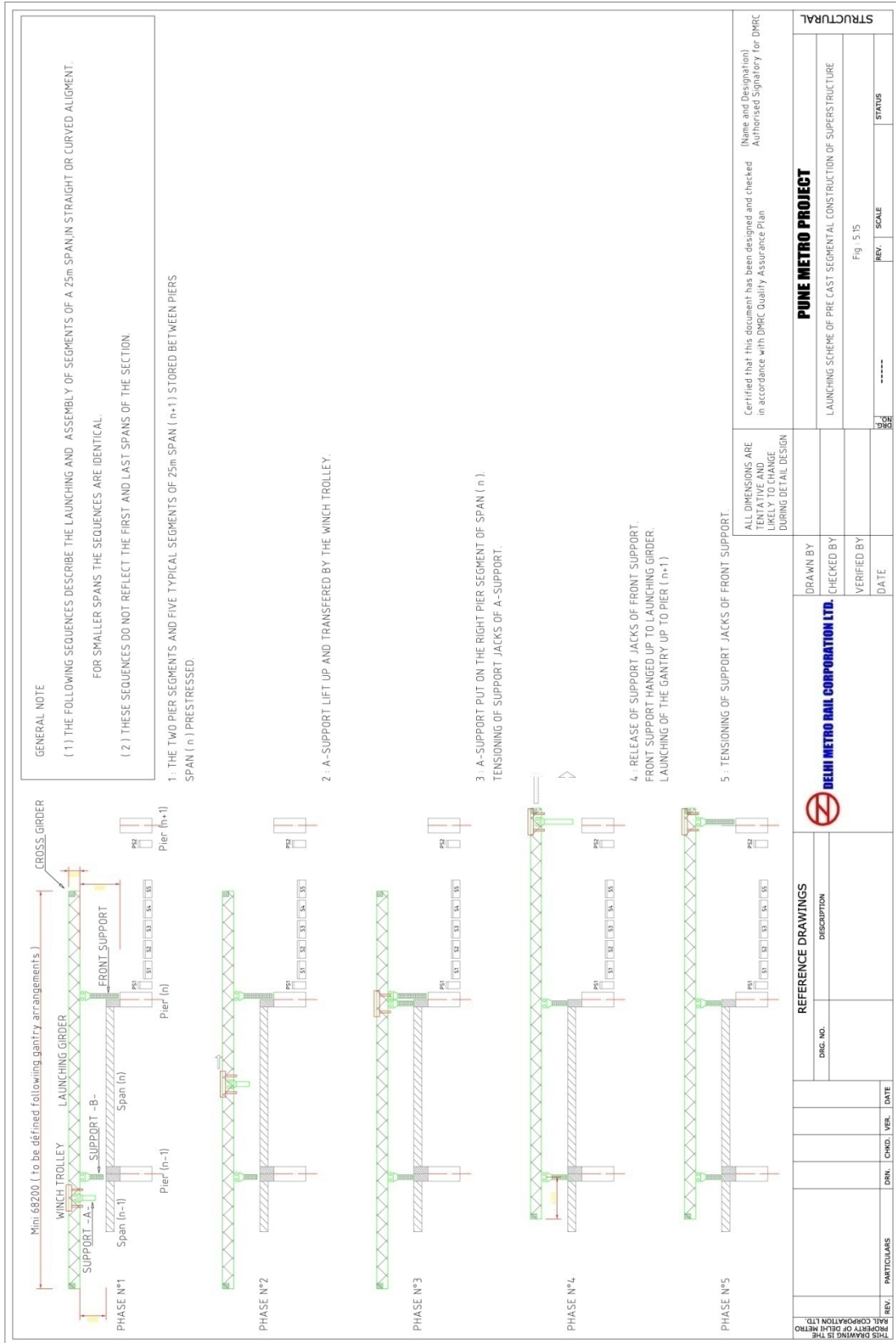


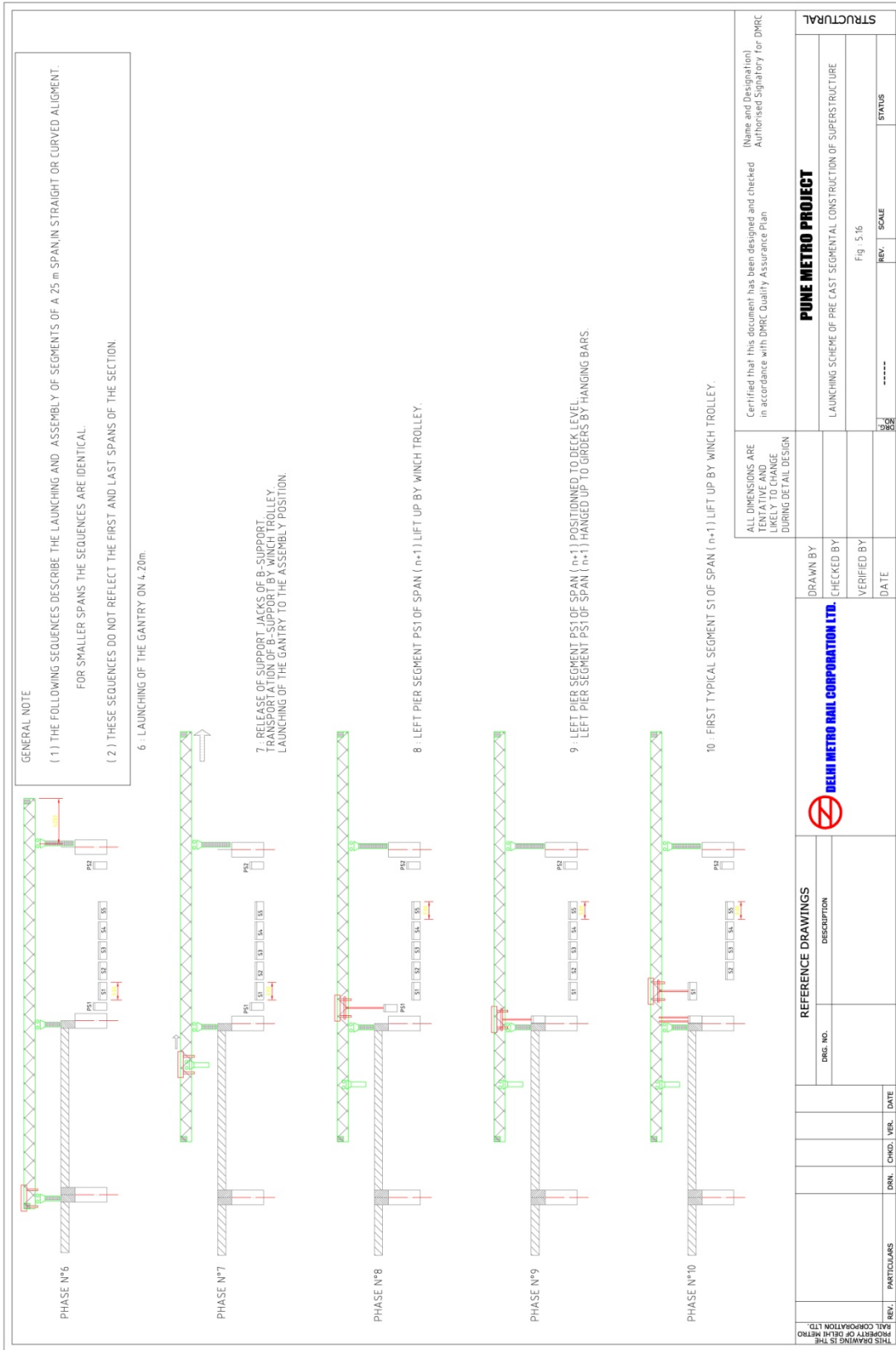
**BORED TUNNEL & UNDERGROUND STATION
CROSS PASSAGE WITH SUMP (TYPICAL SECTION)**

Figure :- 5.14



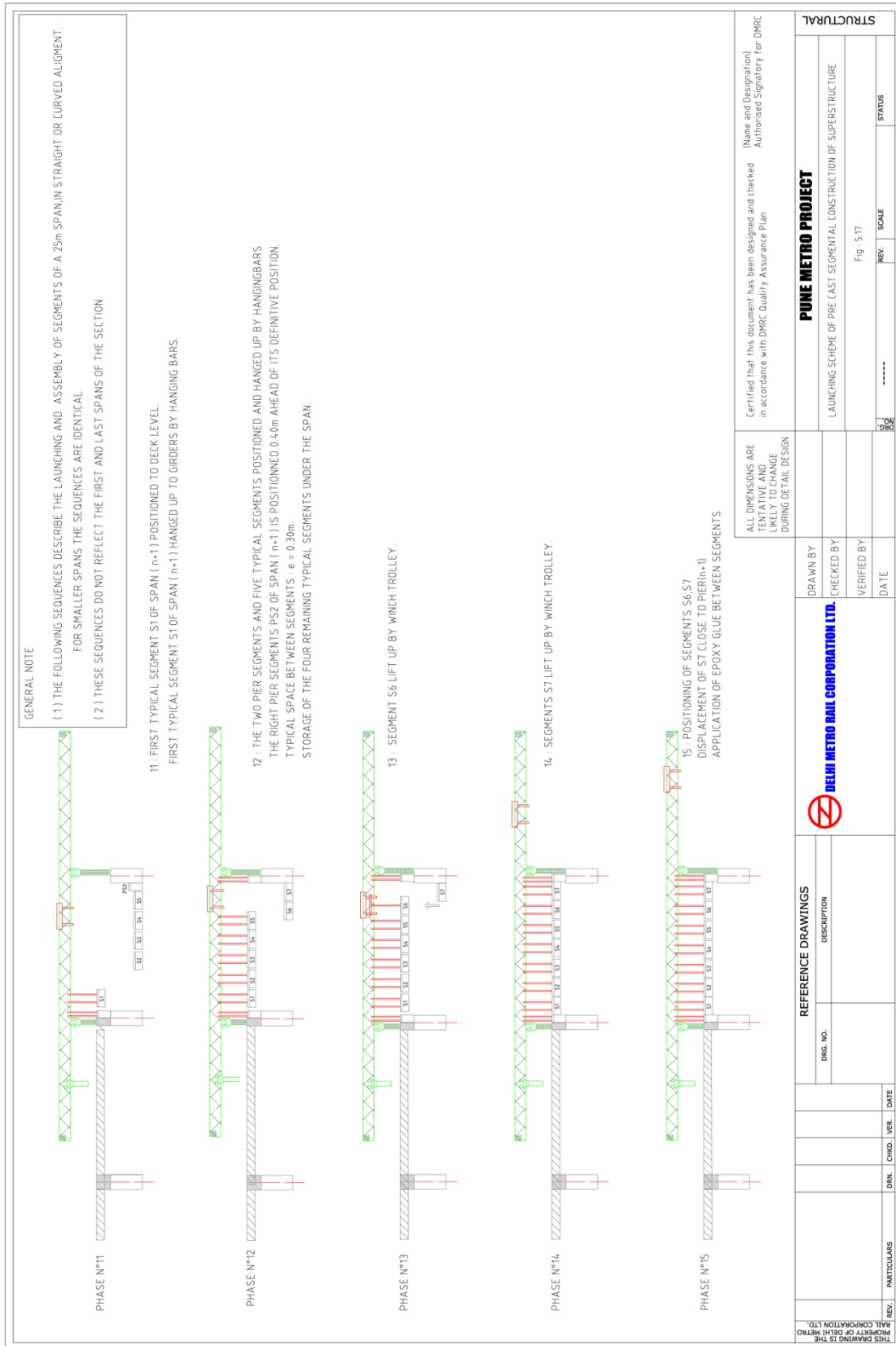
GENERAL ARRANGEMENT OF STANDARD UNIT (SPAN 28.0m c/c OF PIER) 154

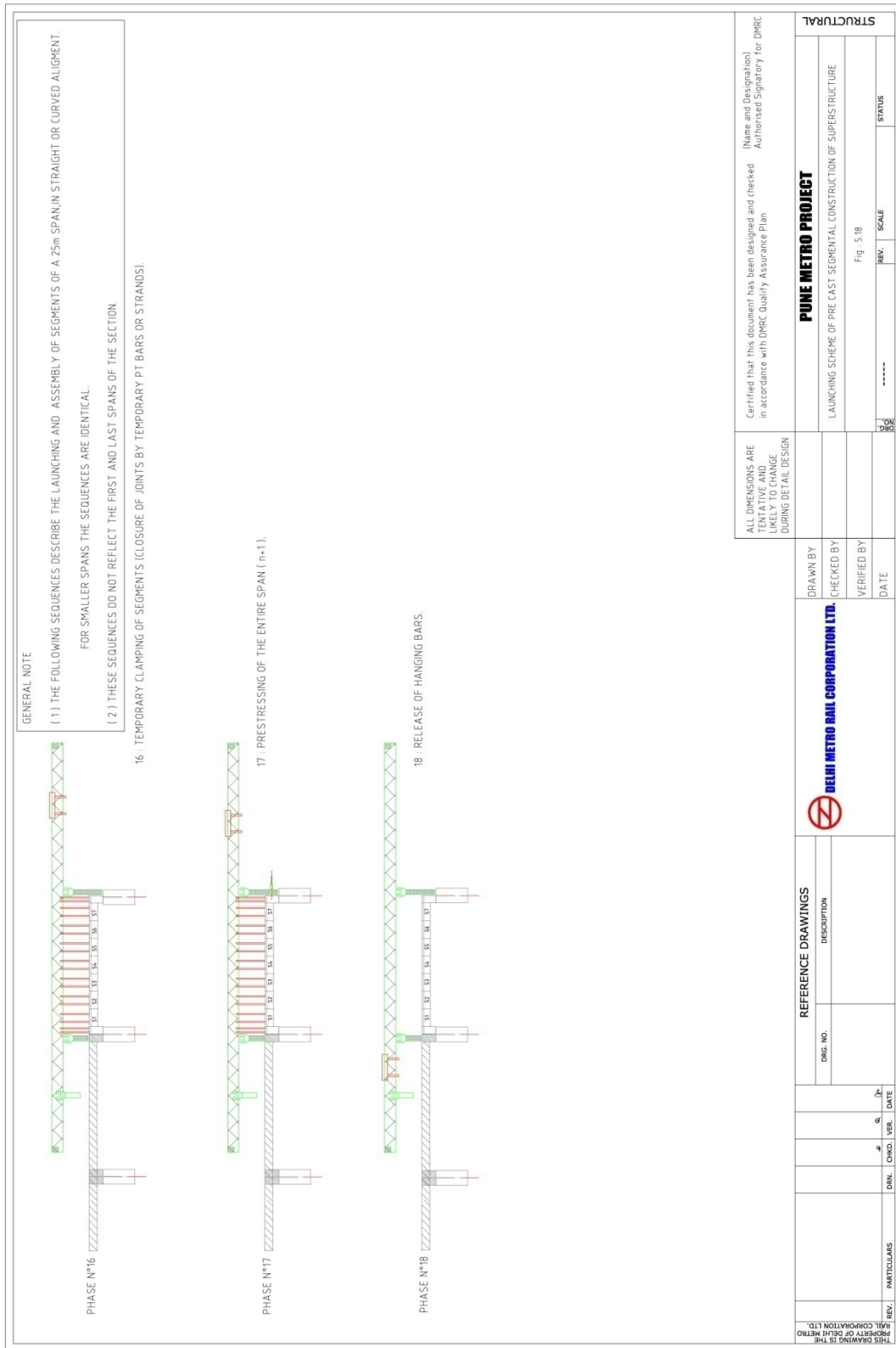


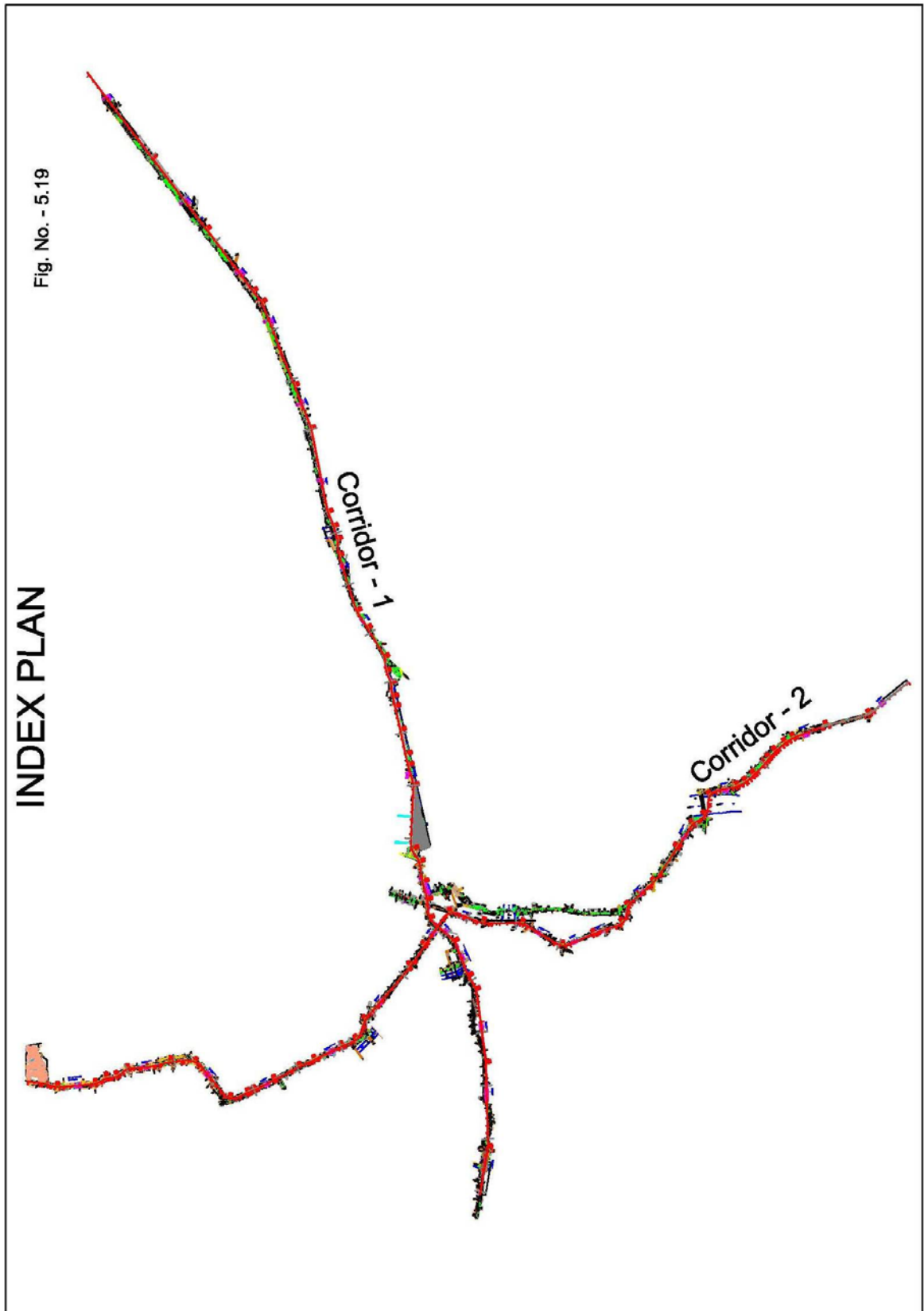


ALL DIMENSIONS ARE TENTATIVE AND LIKELY TO CHANGE DURING DETAIL DESIGN	(Name and Designation) Authorised Signatory for DMRC
Confirmed that this document has been designed and checked in accordance with DMRC Quality Assurance Plan	
PUNE METRO PROJECT	
LAUNCHING SCHEME OF PRE-CAST SEGMENTAL CONSTRUCTION OF SUPERSTRUCTURE	
Fig. 5-16	
REV. _____	SCALE _____
DATE _____	STATUS _____

PROPERTY OF DELHI METRO RAIL CORPORATION LTD.	REFERENCE DRAWINGS	DRG. NO.	DESCRIPTION
REV. _____			
DRAWN BY _____	DELHI METRO RAIL CORPORATION LTD.		
CHECKED BY _____	(Name and Designation) Authorised Signatory for DMRC		
VERIFIED BY _____			
DATE _____			







Chapter - 6

Train Operation Plan



- 6.1 Operation Philosophy
- 6.2 Stations
- 6.3 Train Operation Plan
- 6.4 Vehicle Kilometer
- 6.5 Year Wise rake Requirement



CHAPTER - 6

TRAIN OPERATION PLAN

6.1 OPERATION PHILOSOPHY

The underlying operation philosophy is to make the MRT System more attractive and economical, the main features being:

- Selecting the most optimum frequency of Train services to meet sectional capacity requirement during peak hours on most of the sections.
- Economical & optimum train service frequency not only during peak period, but also during off-peak period.
- A short train consist of 4 coaches with high frequency service which can be increased to 6 Coaches to meet future requirements.
- Multi-tasking of train operation and maintenance staff.

6.2 STATIONS

List of Stations for two corridors of Pune Metro Rail System are given ahead in Table 6.1.

Table 6.1 - List of Stations

S.No	Name of Stations	Change (in m)	Inter - Station Distance (in m)	Remarks
CORRIDOR-1				
	Dead End		(-) 450	-
1	PCMC	0.000	450.000	Elevated
2	Tukaram Nagar	1763.264	1763.264	Elevated
3	Bhosari (Nashik Phata)	2974.275	1211.011	Elevated
4	Kasarwadi	3748.615	774.340	Elevated
5	Fugewadi	4923.064	1174.449	Elevated
6	Dapodi	6018.188	1095.124	Elevated

S.No	Name of Stations	Change (in m)	Inter - Station Distance (in m)		Remarks
7	Bopodi		7206.181	1187.993	Elevated
8	Khadki		7977.395	771.214	Elevated
9	Range Hill		10185.226	2207.831	Elevated
10	Shivaji Nagar		11789.640	1604.414	Underground
11	A S I		12432.292	642.652	Underground
12	Pune Municipal Corporation		12848.000	395.523	Underground
13	BudhwarPeth		13866.261	1038.446	Underground
14	Mandai		14742.084	875.823	Underground
15	Swargate		15688.959	946.875	Underground
	Dead End		16138.959	450.000	
	Total Distance		16588.959or 16.59 km		

Table 6.2 - List of Stations in Corridor 2

S.No	Name of Stations	Change (in km)	Inter - Station Distance (in m)		Remarks
CORRIDOR-2					
	Dead End		(-)684.790	-	
1	Vanaz		0.000	684.790	Elevated
2	Anand Nagar		994.699	994.699	Elevated
3	Ideal Colony		1900.000	905.301	Elevated
4	Nal Stop		2875.274	975.274	Elevated
5	Garware College*		3879.557	1004.283	Elevated
6	Deccan*		4870.687	991.130	Elevated
7	A S I*		6028.870	1158.183	Elevated
8	Civil Court*		6614.791	585.921	Elevated
9	MangalwarPeth		7671.332	1056.541	Elevated
10	Pune Railway Station		8207.489	536.157	Elevated
11	Ruby Clinic		8584.185	376.696	Elevated
12	Bund Garden		9379.712	795.527	Elevated
13	Yerawada		10430.686	1050.974	Elevated
14	Kalyani Nagar		11292.383	861.697	Elevated
15	Ramvadi		12660.667	1368.284	Elevated
	Dead End		14239.667	450.000	
	Total Distance		14924.457or 14.93 km.		

*Between Garware college & City civil court 3 stations proposed (Deccan, Sambhaji park & PMC)

6.3 TRAIN OPERATION PLAN

6.3.1 Salient Features

- Running of services for 19 hours of the day (5 AM to Midnight) with a station dwell time of 30 seconds,
- Make up time of 5-10% with 8-12% coasting.
- Scheduled speed for these corridors has been taken as 33 Kmph for Corridor-1 & 31 Kmph for Corridor-2.

6.3.2 Traffic Demand

Peak hour peak direction traffic demands (PHPDT) for the Pune Metro Corridor-1 & Corridor-2 for the year 2018, 2021 and 2031 for the purpose of planning are indicated in Attachment I/A1, B1 and C1 and Attachment I/A2, B2, and C2 respectively.

6.3.3 Train Formation

To meet the above projected traffic demand, the possibility of running trains with different headways has been examined.

The basic unit of 4-car train comprising of DTC-MC-MC- DTC configuration has been selected for the Pune Metro Corridors for the year 2018, 2021 & 2031.

Composition

DTC : Driving Trailer Car

MC : Motor Car

TC : Trailer Car

4 Car Train Composition DTC + MC + MC+ DTC

6 Car Train Composition DTC + MC + TC + MC + MC + DTC

Capacity

DTC : 247 passenger (Sitting-43, Crush Standing-204)

TC/MC : 270 passenger (Sitting-50, Crush Standing-220)

4 Car Train: 1034 Passengers (Sitting-186, Crush Standing-848)

6 Car Train: 1574 Passengers (Sitting-286, Crush Standing-1288)

Train Operation Plan

Based on the projected PHPDT demand, train operation has been planned for Pune Metro Corridors for the year 2018, 2021 and 2031 as detailed below:

Pune Metro Corridor-1: Pimpri Chinchwad (PCMC) –Swargate

Train operation plan with train carrying **capacity @ 6 persons per square meter of standee area** on Pune Metro Corridor-1 is given below:

- **Year 2018(Refer Attachment I/A1)**

Train operation with **4 car Trains** with headway of **4 min** on Corridor-1 is planned in the first year of operation i.e. **2018** with Peak Hour Peak Direction Capacity of **15510@ 6 persons per square meter of standee area (Capacity of 19740 @ 8 persons per square meter of standee area under dense loading conditions)**.

The maximum PHPDT demand of 17905 is in the Section between Budhwar Peth and Mandai and the PHPDT demand in the section between Pune Municipal Corporation and Budhwar Peth is 17824, demand in the remaining sections is in the range of 6339 to 17586 only. The planned capacity of 15510 (19740 under dense loading) is less than the PHPDT demand in three (zero, with dense loading capacity) sections out of fourteen sections. With this planned PHPDT capacity, optimum utilization of Rolling Stock will be achieved and empty running of trains will be considerably reduced. However, the Rolling Stock is designed for carrying higher density loading @ 8 standee passengers per square meter and in the sections in which PHPDT capacity exceeds the planned capacity, overloading during these periods will help in reducing the demand for increased deployment of Rolling Stock. Traffic demand and train capacity for this corridor in the year 2018 is tabulated and represented on a chart enclosed as Attachment I/A1.

- **Year 2021 (Refer Attachment I/B1)**

Train operation with **4 car Trains** with headway of **3.5 min** on Corridor-1 is planned in the year **2021** with Peak Hour Peak Direction Capacity of **17726@ 6 persons per square meter of standee area (Capacity of 22560 @ 8 persons per square meter of standee area under dense loading conditions)**.

The maximum PHPDT demand of 18961 is in the Section between Bopodi and Khadki and the PHPDT demand in the section between Khadki and Hill Range is 18344, demand in the remaining sections is in the range of 9744 to 18091 only. The planned capacity of 17726 (22560 under dense loading) is less than the PHPDT demand in

three (zero, with dense loading capacity) sections out of fourteen sections. With this planned PHPDT capacity, optimum utilization of Rolling Stock will be achieved and empty running of trains will be considerably reduced. However, the Rolling Stock is designed for carrying higher density loading @ 8 standee passengers per square meter and in the sections in which PHPDT capacity exceeds the planned capacity, overloading during these periods will help in reducing the demand for increased deployment of Rolling Stock. Traffic demand and train capacity for this corridor in the year 2021 is tabulated and represented on a chart enclosed as Attachment I/B1.

- **Year 2031 (Refer Attachment I/C1)**

Train operation with **4 car Trains** with headway of **3.5 min** on Corridor-1 is planned in the year **2031** with Peak Hour Peak Direction Capacity of **17726 @ 6 persons per square meter of standee area (Capacity of 22560 @ 8 persons per square meter of standee area under dense loading conditions)**.

The maximum PHPDT demand of 20035 is in the Section between Bopodi and Khadki and the PHPDT demand in the section between Khadki & Hill Range and is 18928, demand in the remaining sections is in the range of 11309 to 18704 only. The planned capacity of 17726 (22560 under dense loading) is less than the PHPDT demand in seven (zero, with dense loading capacity) sections out of fourteen sections. With this planned PHPDT capacity, optimum utilization of Rolling Stock will be achieved and empty running of trains will be considerably reduced. However, the Rolling Stock is designed for carrying higher density loading @ 8 standee passengers per square meter and in the sections in which PHPDT capacity exceeds the planned capacity, overloading during these periods will help in reducing the demand for increased deployment of Rolling Stock. Traffic demand and train capacity for this corridor in the year 2031 is tabulated and represented on a chart enclosed as Attachment I/C1.

Pune Metro Corridor-2: Vanaz-Ramwadi

Train operation plan with train carrying **capacity @ 6 persons per square meter of standee area** on Pune Metro Corridor-2 is given below:

- **Year 2018(Refer Attachment I/ A2)**

Train operation with **4 car Trains** with headway of **12 min** on Corridor-2 is planned in the first year of operation i.e. **2018** with Peak Hour Peak Direction Capacity of **5170 @ 6 persons per square meter of standee area (Capacity of 6580 @ 8 persons per square meter of standee area under dense loading conditions)**.

The maximum PHPDT demand of 6203 is in the Section between Mangalwar Peth and Pune Railway Station and the PHPDT demand in the section Garware College and

Deccan is 5966, demand in the remaining sections is in the range of 1100 to 5753 only. The planned capacity of 5170 (6580 under dense loading) is less than the PHPDT demand in four (zero, with dense loading capacity) sections out of fourteen sections. With this planned PHPDT capacity, optimum utilization of Rolling Stock will be achieved and empty running of trains will be considerably reduced. However, the Rolling Stock is designed for carrying higher density loading @ 8 standee passengers per square meter and in the sections in which PHPDT capacity exceeds the planned capacity, overloading during these periods will help in reducing the demand for increased deployment of Rolling Stock. Traffic demand and train capacity for this corridor in the year 2018 is tabulated and represented on a chart enclosed as Attachment I/A2 respectively.

- **Year 2021 (Refer Attachment I/B2)**

Train operation with **4 car Trains** with headway of **8 min** on Corridor-2 is planned in the year **2021** with Peak Hour Peak Direction Capacity of **7755@ 6 persons per square meter of standee area (Capacity of 9870 @ 8 persons per square meter of standee area under dense loading conditions)**.

The maximum PHPDT demand of 8519 is in the Section between Mangalwar Peth and Pune Railway Station and the PHPDT demand in the section between Garware College and Deccan is 7883, demand in the remaining sections is in the range of 1381 to 7194 only. The planned capacity of 7755 (9870 under dense loading) is less than the PHPDT demand in two (zero, with dense loading capacity) sections out of fourteen sections. With this planned PHPDT capacity, optimum utilization of Rolling Stock will be achieved and empty running of trains will be considerably reduced. However, the Rolling Stock is designed for carrying higher density loading @ 8 standee passengers per square meter and in the sections in which PHPDT capacity exceeds the planned capacity, overloading during these periods will help in reducing the demand for increased deployment of Rolling Stock. Traffic demand and train capacity for this corridor in the year 2021 is tabulated and represented on a chart enclosed as Attachment I/B2.

- **Year 2031 (Refer Attachment I/C2)**

Train operation with **4 car Trains** with headway of **6.5 min** on Corridor-2 is planned in the year **2031** with Peak Hour Peak Direction Capacity of **9545 @ 6 persons per square meter of standee area (Capacity of 12148 @ 8 persons per square meter of standee area under dense loading conditions)**.

The maximum PHPDT demand of 10982 is in the Section between Deccan and ASI and the PHPDT demand in the section between Garware College and Deccan is 10591, demand in the remaining sections is in the range of 1661 to 10320 only. The planned

capacity of 9545 (12148 under dense loading) is less than the PHPDT demand in five (zero, with dense loading capacity) sections out of fourteen sections. With this planned PHPDT capacity, optimum utilization of Rolling Stock will be achieved and empty running of trains will be considerably reduced. However, the Rolling Stock is designed for carrying higher density loading @ 8 standee passengers per square meter and in the sections in which PHPDT capacity exceeds the planned capacity, overloading during these periods will help in reducing the demand for increased deployment of Rolling Stock. Traffic demand and train capacity for this corridor in the year 2031 is tabulated and represented on a chart enclosed as Attachment I/C2.

In case of any mismatch in the capacity provided and the actual traffic, the capacity can be moderated suitably by either varying the rake composition or adjusting the Headway.

Based on traffic projections, requirement of 4-car trains is envisaged even in the Year 2031. However, the length of the train can be increased to 6-car based on actual traffic requirements and all infrastructure and maintenance facilities should be planned for 6-car trains.

The PHPDT capacity provided on the two corridors in different years of operation is tabulated below:

Table 6.3 - Capacity Provided for Corridor-1

LINE	YEAR		
	2018	2021	2031
Pune Metro Corridor-1			
Cars/trains	4	4	4
Head way (Minutes)	4	3.5	3.5
Max. PHPDT Demand	17905	18961	20035
PHPDT Capacity Available	15510 (19740*)	17726 (22560*)	17726 (22560*)

* @ 8 persons per square meter of standee area

Table 6.4 - Capacity Provided for Corridor-2

LINE	YEAR		
	2018	2021	2031
Pune Metro Corridor-2			
Cars/trains	4	4	4
Head way (Minutes)	12	8	8
Max. PHPDT Demand	6203	8519	10982
PHPDT Capacity Available	5170 (6580*)	7755 (9870*)	9545 (12148*)

* @ 8 persons per square meter of standee area

6.3.4 Train Frequency

Pune Metro Corridor

The train operation of Pune Metro provides the following train frequency:

Pune Metro Corridor	2018		2021		2031	
	Peak Hour h/w	Lean Hour h/w	Peak Hour h/w	Lean Hour h/w	Peak Hour h/w	Lean Hour h/w
Corridor-1: PimpriChinchwad (PCMC) - Swargate	4min	6 to 15min	3.5min	6 to 15min	3.5min	6 to 15min
Corridor-2: Vanaz - Ramwadi	12min	16 to 30min	8min	12 to 30min	6.5min	8 to 15min

No services are proposed between 00.00 hrs to 5.00 hrs, which are reserved for maintenance of infrastructure and rolling stock.

6.3.5 Hourly Train Operation plan

The hourly distribution of daily transport capacity is presented in Table 6.6, 6.7, & 6.8 and 6.6A, 6.7A, & 6.8A for years 2018, 2021 & 2031 for Corridor -1 & 2 respectively and enclosed as **Attachment II**. Number of train trips per direction per day for Corridor 1 & 2 is worked out as 178 & 68 in the year 2018, 193 & 89 in the year 2021 and 193 & 135 for in the year 2031 respectively. The directional splits for Corridor-1 and Corridor-2 are presented in **Table 6.9 and 6.10** enclosed as **Attachment III**.

6.4 VEHICLE KILOMETER

Based on above planning, after considering maintenance period and assuming 340 days in service in a year, Vehicle Kilometers for Pune Metro Corridor-1 & 2 is given in **Table 6.11 and 6.12** enclosed as **Attachment IV**.

6.5 YEAR WISE RAKE REQUIREMENT

Based on Train formation and headway as decided above to meet Peak Hour Peak Direction Traffic Demand, Rake requirement has been calculated and enclosed as **Attachment V** & has been tabulated below:

Table 6.5 – Rake Requirement

Corridor	Year	Headway (min)	No. of Rakes	Rake Consist	No. of Coaches
Pune Metro Corridor-1	2018	4	19	4 car	76
	2021	3.5	22	4 car	88
	2031	3.5	22	4 car	88

Corridor	Year	Headway (min)	No. of Rakes	Rake Consist	No. of Coaches
Pune Metro Corridor-2	2018	12	7	4 car	28
	2021	8	10	4 car	40
	2031	6.5	12	4 car	48

Requirements of coaches is calculated based on following assumptions-

Assumptions –

- (i) Train Composition planned as under
 - 4 Car Train Composition : DTC-MC-MC-DTC
 - Train Carrying Capacity of 4 Car Train : 1034 passengers
- (ii) Coach requirement has been calculated based on headway during peak hours.
- (iii) Traffic reserve is taken as one train per section to cater to failure of train on line and to make up for operational time lost.
- (iv) Repair and maintenance reserve has been estimated as 8 % of total requirement (Bare +Traffic Reserve).
- (v) The calculated number of rakes in fraction is rounded off to next higher number.
- (vi) Schedule speed is taken as 33 KMPH & 31 KMPH respectively for Corridor 1 & 2.
- (vii) Total Turn round time is taken as 6 min at terminal stations.

Attachment - I/A1

PHPDT Demand and Capacity Chart

Corridor 1: Pimpri Chinchwad (PCMC) - Swargate

Year: 2018

No. of Cars per Train: 4

Passenger Capacity @ 6 persons/sqm of a 4-Car Train: 1034

Passenger Capacity @ 8 persons/sqm of a 4-Car Train: 1316

Headway (min) 4

S.N	FROM	TO	Traffic Demand in PHPDT	PHPDT capacity @ 6p/sqm of standee area	PHPDT capacity @ 8p/sqm of standee area
1	PCMC	Tukaram Nagar	6339	15510	19740
2	Tukaram Nagar	Bhosari	8711	15510	19740
3	Bhosari	Kasarvadi	9829	15510	19740
4	Kasarvadi	Fujewadi	11097	15510	19740
5	Fujewadi	Dopodi	11378	15510	19740
6	Dopodi	Bopodi	13147	15510	19740
7	Bopodi	Khadki	14509	15510	19740
8	Khadki	Hill Range	14231	15510	19740
9	Hill Range	Shivaji Nagar	14465	15510	19740
10	Shivaji Nagar	A S I	13367	15510	19740
11	A S I	Pune Municipal Corporation	14756	15510	19740
12	Pune Municipal Corporation	Budhwar Peth	17824	15510	19740
13	Budhwar Peth	Mandai	17905	15510	19740
14	Mandai	Swargate	17586	15510	19740

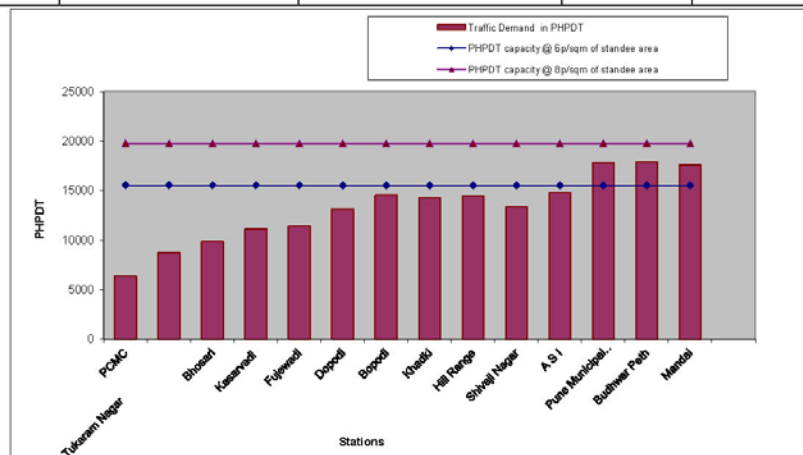


Fig 1.1

Attachment - I/A2

**PHPDT Demand and Capacity Chart
Corridor 2: Vanaz - Ramvadi**

Year: 2018
 No. of Cars per Train: 4
 Passenger Capacity @ 6 persons/sqm of a 4-Car Train: 1034
 Passenger Capacity @ 8 persons/sqm of a 4-Car Train: 1316
 Headway (min): 12

S.N	FROM	TO	Traffic Demand in PHPDT	PHPDT capacity @ 6p/sqm of standee area	PHPDT capacity @ 8p/sqm of standee area
1	Vanaz	Anand Nagar	2168	5170	6580
2	Anand Nagar	Ideal Colony	2469	5170	6580
3	Ideal Colony	Nal Stop	2493	5170	6580
4	Nal Stop	Garware College	4654	5170	6580
5	Garware College	Deccan	5966	5170	6580
6	Deccan	AS I	5753	5170	6580
7	AS I	Civil Court	5054	5170	6580
8	Civil Court	Mangalwar Peth	4605	5170	6580
9	Mangalwar Peth	Pune Railway Station	6203	5170	6580
10	Pune Railway Station	Ruby Clinic	5265	5170	6580
11	Ruby Clinic	Bund Garden	5044	5170	6580
12	Bund Garden	Yerawada	4086	5170	6580
13	Yerawada	Kalyani Nagar	3443	5170	6580
14	Kalyani Nagar	Ramvadi	1100	5170	6580

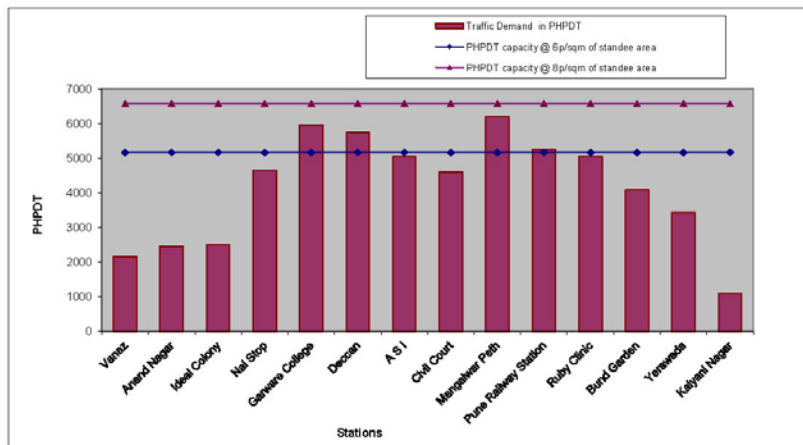


Fig 1.2

Attachment - I/B1

PHPDT Demand and Capacity Chart
Corridor 1: Pimpri Chinchwad (PCMC) - Swargate

Year: 2021
 No. of Cars per Train: 4
 Passenger Capacity @ 6 persons/sqm of a 4-Car Train: 1034
 Passenger Capacity @ 8 persons/sqm of a 4-Car Train: 1316
 Headway (min): 3.5

S.N	FROM	TO	Traffic Demand in PHPDT	PHPDT capacity @ 6p/sqm of standee area	PHPDT capacity @ 8p/sqm of standee area
1	PCMC	Tukaram Nagar	9744	17726	22560
2	Tukaram Nagar	Bhosari	12598	17726	22560
3	Bhosari	Kasarvadi	14334	17726	22560
4	Kasarvadi	Fujewadi	15460	17726	22560
5	Fujewadi	Dopodi	15692	17726	22560
6	Dopodi	Bopodi	17357	17726	22560
7	Bopodi	Khadki	18961	17726	22560
8	Khadki	Hill Range	18344	17726	22560
9	Hill Range	Shivaji Nagar	18091	17726	22560
10	Shivaji Nagar	A S I	16596	17726	22560
11	A S I	Pune Municipal Corporation	14873	17726	22560
12	Pune Municipal Corporation	Budhwar Peth	17688	17726	22560
13	Budhwar Peth	Mandai	17096	17726	22560
14	Mandai	Swargate	16487	17726	22560

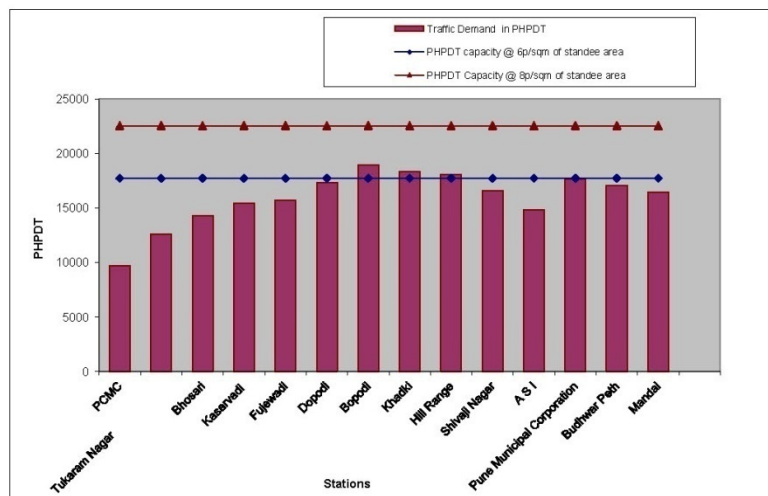


Fig 2.1

Attachment - I/B2

**PHPDT Demand and Capacity Chart
Corridor 2: Vanaz - Ramvadi**

Year: 2021
 No. of Cars per Train: 4
 Passenger Capacity @ 6 persons/sqm of a 4-Car Train: 1034
 Passenger Capacity @ 8 persons/sqm of a 4-Car Train: 1316
 Headway (min): 8

S.N	FROM	TO	Traffic Demand in PHPDT	PHPDT capacity @ 6p/sqm of standee area	PHPDT capacity @ 8p/sqm of standee area
1	Vanaz	Anand Nagar	4134	7755	9870
2	Anand Nagar	Ideal Colony	4371	7755	9870
3	Ideal Colony	Nal Stop	4392	7755	9870
4	Nal Stop	Garware College	7254	7755	9870
5	Garware College	Deccan	7883	7755	9870
6	Deccan	AS I	7194	7755	9870
7	AS I	Civil Court	6431	7755	9870
8	Civil Court	Mangalwar Peth	6152	7755	9870
9	Mangalwar Peth	Pune Railway Station	8519	7755	9870
10	Pune Railway Station	Ruby Clinic	7106	7755	9870
11	Ruby Clinic	Bund Garden	6691	7755	9870
12	Bund Garden	Yerawada	5405	7755	9870
13	Yerawada	Kalyani Nagar	4394	7755	9870
14	Kalyani Nagar	Ramvadi	1381	7755	9870

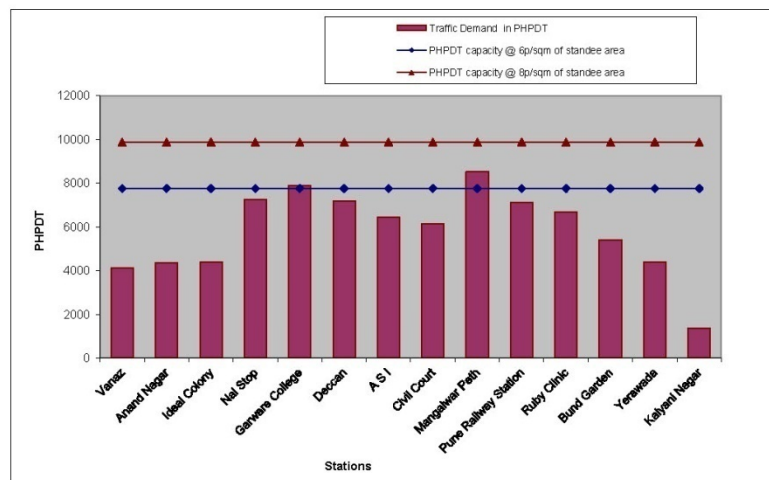


Fig 2.2

Attachment - I/C1
**PHPDT Demand and Capacity Chart
Corridor 1: Pimpri Chinchwad (PCMC) - Swargate**

Year: 2031
 No. of Cars per Train: 4
 Passenger Capacity @ 6 persons/sqm of a 4-Car Train: 1034
 Passenger Capacity @ 8 persons/sqm of a 4-Car Train: 1316
 Headway (min): 3.5

S.N	FROM	TO	Traffic Demand in PHPDT	PHPDT capacity @ 6p/sqm of standee area	PHPDT capacity @ 8p/sqm of standee area
1	PCMC	Tukaram Nagar	11309	17726	22560
2	Tukaram Nagar	Bhosari	13716	17726	22560
3	Bhosari	Kasarvadi	15691	17726	22560
4	Kasarvadi	Fujewadi	16937	17726	22560
5	Fujewadi	Dopodi	17195	17726	22560
6	Dopodi	Bopodi	18521	17726	22560
7	Bopodi	Khadki	20035	17726	22560
8	Khadki	Hill Range	18928	17726	22560
9	Hill Range	Shivaji Nagar	18508	17726	22560
10	Shivaji Nagar	A S I	16667	17726	22560
11	A S I	Pune Municipal Corporation	15803	17726	22560
12	Pune Municipal Corporation	Budhwar Peth	18704	17726	22560
13	Budhwar Peth	Mandai	18653	17726	22560
14	Mandai	Swargate	18505	17726	22560

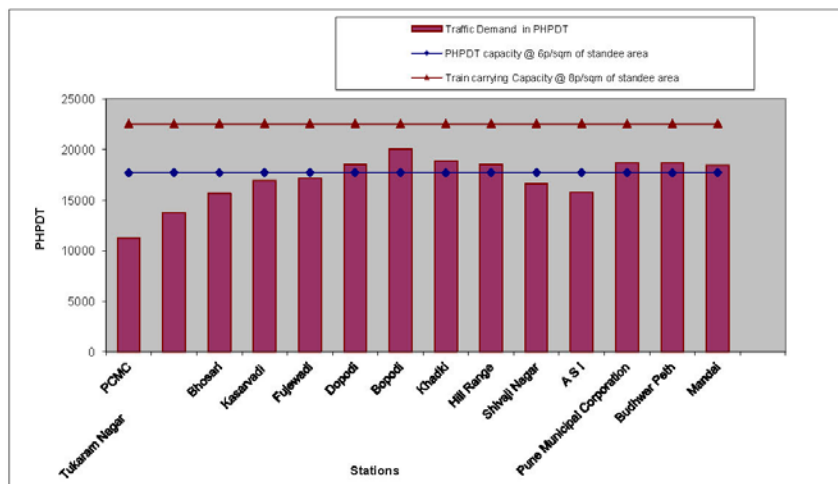


Fig 3.1

Attachment - I/C2

**PHPDT Demand and Capacity Chart
Corridor 2: Vanaz - Ramvadi**

Year: 2031
 No. of Cars per Train: 4
 Passenger Capacity @ 6 persons/sqm of a 4-Car Train: 1034
 Passenger Capacity @ 8 persons/sqm of a 4-Car Train: 1316
 Headway (min): 6.5

S.N	FROM	TO	Traffic Demand in PHPDT	PHPDT capacity @ 6p/sqm of standee area	PHPDT capacity @ 8p/sqm of standee area
1	Vanaz	Anand Nagar	5833	9545	12148
2	Anand Nagar	Ideal Colony	6289	9545	12148
3	Ideal Colony	Nal Stop	6294	9545	12148
4	Nal Stop	Garware College	9872	9545	12148
5	Garware College	Deccan	10591	9545	12148
6	Deccan	A S I	10982	9545	12148
7	A S I	Civil Court	10226	9545	12148
8	Civil Court	Mangalwar Peth	7990	9545	12148
9	Mangalwar Peth	Pune Railway Station	10320	9545	12148
10	Pune Railway Station	Ruby Clinic	8227	9545	12148
11	Ruby Clinic	Bund Garden	7692	9545	12148
12	Bund Garden	Yerawada	6278	9545	12148
13	Yerawada	Kalyani Nagar	5032	9545	12148
14	Kalyani Nagar	Ramvadi	1661	9545	12148

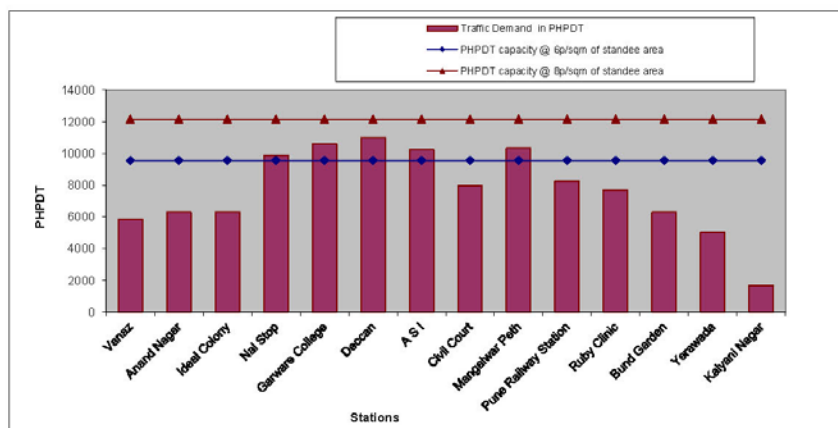


Fig 3.2

Attachment II

TABLE 6.6
Hourly Train Operation Plan for Corridor 1: Pimpri Chinchwad (PCMC) -
Year: 2018
Configuration: 4 Car
Headway(min): 4

Time of Day	Headway in Minutes	No. of Trains per day	
		UP	DN
5 to 6	12	5	5
6 to 7	10	6	6
7 to 8	6	10	10
8 to 9	4	15	15
9 to 10	4	15	15
10 to 11	4	15	15
11 to 12	6	10	10
12 to 13	10	6	6
13 to 14	12	5	5
14 to 15	12	5	5
15 to 16	10	6	6
16 to 17	6	10	10
17 to 18	4	15	15
18 to 19	4	15	15
19 to 20	4	15	15
20 to 21	6	10	10
21 to 22	10	6	6
22 to 23	12	5	5
23 to 24	15	4	4
Total No. of train trips per direction per day		178	178

Attachment II

TABLE 6.7
Hourly Train Operation Plan for Corridor 1: Pimpri Chinchwad (PCMC) -
Year: 2021
Configuration: 4 Car
Headway(min): 3.5

Time of Day	Headway in Minutes	No. of Trains per day	
		UP	DN
5 to 6	12	5	5
6 to 7	10	6	6
7 to 8	6	10	10
8 to 9	3.5	17	18
9 to 10	3.5	18	17
10 to 11	3.5	17	18
11 to 12	6	10	10
12 to 13	10	6	6
13 to 14	12	5	5
14 to 15	12	5	5
15 to 16	10	6	6
16 to 17	6	10	10
17 to 18	3.5	18	17
18 to 19	3.5	17	18
19 to 20	3.5	18	17
20 to 21	6	10	10
21 to 22	10	6	6
22 to 23	12	5	5
23 to 24	15	4	4
Total No. of train trips per direction per day		193	193

Attachment II

TABLE 6.8
Hourly Train Operation Plan for Corridor 1: Pimpri Chinchwad (PCMC) -
Year: 2031
Configuration: 4 Car
Headway(min): 3.5

Time of Day	Headway in Minutes	No. of Trains per day	
		UP	DN
5 to 6	12	5	5
6 to 7	10	6	6
7 to 8	6	10	10
8 to 9	3.5	17	18
9 to 10	3.5	18	17
10 to 11	3.5	17	18
11 to 12	6	10	10
12 to 13	10	6	6
13 to 14	12	5	5
14 to 15	12	5	5
15 to 16	10	6	6
16 to 17	6	10	10
17 to 18	3.5	18	17
18 to 19	3.5	17	18
19 to 20	3.5	18	17
20 to 21	6	10	10
21 to 22	10	6	6
22 to 23	12	5	5
23 to 24	15	4	4
Total No. of train trips per direction per day		193	193

Attachment II

TABLE 6.6A
Hourly Train Operation Plan for Corridor 2: Vanaz - Ramvadi
Year: 2018
Configuration: 4 Car
Headway(min): 12

Time of Day	Headway in Minutes	No. of Trains per day	
		UP	DN
5 to 6	24	3	2
6 to 7	20	3	3
7 to 8	16	4	3
8 to 9	12	5	5
9 to 10	12	5	5
10 to 11	12	5	5
11 to 12	16	4	3
12 to 13	20	3	3
13 to 14	24	3	2
14 to 15	24	2	3
15 to 16	20	3	3
16 to 17	16	3	4
17 to 18	12	5	5
18 to 19	12	5	5
19 to 20	12	5	5
20 to 21	16	3	4
21 to 22	20	3	3
22 to 23	24	2	3
23 to 24	30	2	2
Total No. of train trips per direction per day		68	68

Attachment II

TABLE 6.7A
Hourly Train Operation Plan for Corridor 2: Vanaz - Ramvadi
Year: 2021
Configuration: 4 Car
Headway(min): 8

Time of Day	Headway in Minutes	No. of Trains per day	
		UP	DN
5 to 6	24	3	2
6 to 7	20	3	3
7 to 8	12	5	5
8 to 9	8	7	8
9 to 10	8	8	7
10 to 11	8	7	8
11 to 12	12	5	5
12 to 13	20	3	3
13 to 14	24	3	2
14 to 15	24	2	3
15 to 16	20	3	3
16 to 17	12	5	5
17 to 18	8	8	7
18 to 19	8	7	8
19 to 20	8	8	7
20 to 21	12	5	5
21 to 22	20	3	3
22 to 23	24	2	3
23 to 24	30	2	2
Total No. of train trips per direction per day		89	89

Attachment II

TABLE 6.8A
Hourly Train Operation Plan for Corridor 2: Vanaz - Ramvadi
Year: 2031
Configuration: 4 Car
Headway(min): 6.5

Time of Day	Headway in Minutes	No. of Trains per day	
		UP	DN
5 to 6	12	5	5
6 to 7	10	6	6
7 to 8	8	8	7
8 to 9	6.5	9	10
9 to 10	6.5	10	9
10 to 11	6.5	9	10
11 to 12	8	8	7
12 to 13	10	6	6
13 to 14	12	5	5
14 to 15	12	5	5
15 to 16	10	6	6
16 to 17	8	7	8
17 to 18	6.5	10	9
18 to 19	6.5	9	10
19 to 20	6.5	10	9
20 to 21	8	7	8
21 to 22	10	6	6
22 to 23	12	5	5
23 to 24	15	4	4
Total No. of train trips per direction per day		135	135

Attachment III

TABLE 6.9
Corridor 1: Pimpri Chinchwad (PCMC) - Swargate
PHPDT for the Year 2018

S.No	From Station	To Station	Maximum PHPDT	Directional Split to Swargate	Directional Split to PCMC
1	PCMC	Tukaram Nagar	6339	50%	50%
2	Tukaram Nagar	Bhosari	8711	50%	50%
3	Bhosari	Kasarvadi	9829	50%	50%
4	Kasarvadi	Fujewadi	11097	50%	50%
5	Fujewadi	Dopodi	11378	50%	50%
6	Dopodi	Bopodi	13147	50%	50%
7	Bopodi	Khadki	14509	50%	50%
8	Khadki	Hill Range	14231	50%	50%
9	Hill Range	Shivaji Nagar	14465	50%	50%
10	Shivaji Nagar	A SI	13367	50%	50%
11	A SI	Pune Municipal Corporation	14756	50%	50%
12	Pune Municipal Corporation	Budhwar Peth	17824	50%	50%
13	Budhwar Peth	Mandai	17905	50%	50%
14	Mandai	Swargate	17586	50%	50%

TABLE 6.10
Corridor 2: Vanaz - Ramvadi
PHPDT for the Year 2018

S.No	From Station	To Station	Maximum PHPDT	Directional Split to Ramvadi	Directional Split to Vanaz
1	Vanaz	Anand Nagar	2168	50%	50%
2	Anand Nagar	Ideal Colony	2469	50%	50%
3	Ideal Colony	Nal Stop	2493	50%	50%
4	Nal Stop	Garware College	4654	50%	50%
5	Garware College	Deccan	5966	50%	50%
6	Deccan	A SI	5753	50%	50%
7	A SI	Civil Court	5054	50%	50%
8	Civil Court	Mangalwar Peth	4605	50%	50%
9	Mangalwar Peth	Pune Railway Station	6203	50%	50%
10	Pune Railway Station	Ruby Clinic	5265	50%	50%
11	Ruby Clinic	Bund Garden	5044	50%	50%
12	Bund Garden	Yerawada	4086	50%	50%
13	Yerawada	Kalyani Nagar	3443	50%	50%
14	Kalyani Nagar	Ramvadi	1100	50%	50%

Attachment IV

TABLE 6.11
Vehicle Kilometer
Corridor 1: Pimpri Chinchwad (PCMC) - Swargate

Year	2018	2021	2031
Section Length	15.69	15.69	15.69
No of cars per Train	4	4	4
No of working Days in a year	340	340	340
Number of Trains per day each Way	178	193	193
Daily Train -KM	5585	6056	6056
Annual Train - KM (10⁵)	18.99	20.59	20.59
Annual Vehicle - KM (10⁵)	75.96	82.36	82.36

TABLE 6.12
Vehicle Kilometer
Corridor 2: Vanaz - Ramvadi

Year	2018	2021	2031
Section Length	13.79	13.79	13.79
No of cars per Train	4	4	4
No of working Days in a year	340	340	340
Number of Trains per day each Way	68	89	135
Daily Train -KM	1875	2455	3723
Annual Train - KM (10⁵)	6.38	8.35	12.66
Annual Vehicle - KM (10⁵)	25.51	33.38	50.64

Attachment V

Rake Requirement

Corridor 1: Pimpri Chinchwad (PCMC) - Swargate, Year: 2018
 Passenger Capacity @ 6 Persons/sqm in 4 Car Train: 1034
 Schedule Speed in Km/h = 33

Section	Distance (kms)	Schedule Speed in kmph	Projected PHPDT Demand	Max. PHPDT Capacity Available	Headway (min)	Rake Requirement		Total No of Rakes	No. of Cars per rake	No. of Cars	
						Bare	Traffic Reserve				
Corridor 1: Pimpri Chinchwad (PCMC) - Swargate	15.69	33.0	17905	15510	4	16	1	2	19	4	76
Total Turn Round Time(min) 6											

Corridor 1: Pimpri Chinchwad (PCMC) - Swargate, Year: 2021
 Passenger Capacity @ 6 Persons/sqm in 4 Car Train: 1034
 Schedule Speed in Km/h = 33

Section	Distance (kms)	Schedule Speed in kmph	Projected PHPDT Demand	Max. PHPDT Capacity Available	Headway (min)	Rake Requirement		Total No of Rakes	No. of Cars per rake	No. of Cars	
						Bare	Traffic Reserve				
Corridor 1: Pimpri Chinchwad (PCMC) - Swargate	15.69	33.0	18961	17726	3.5	19	1	2	22	4	88
Total Turn Round Time(min) 6											

Corridor 1: Pimpri Chinchwad (PCMC) - Swargate, Year: 2031
 Passenger Capacity @ 6 Persons/sqm in 4 Car Train: 1034
 Schedule Speed in Km/h = 33

Section	Distance (kms)	Schedule Speed in kmph	Projected PHPDT Demand	Max. PHPDT Capacity Available	Headway (min)	Rake Requirement		Total No of Rakes	No. of Cars per rake	No. of Cars	
						Bare	Traffic Reserve				
Corridor 1: Pimpri Chinchwad (PCMC) - Swargate	15.69	33.0	20035	17726	3.5	19	1	2	22	4	88
Total Turn Round Time(min) 6											

Attachment V

Rake Requirement

Corridor 2: Vanaz - Ramvadi, Year : 2018
 Passenger Capacity @ 6 Persons/sqm in 4 Car Train: 1034
 Schedule Speed in Km/h = 31

Section	Distance (kms)	Schedule Speed in kmph	Projected PHPDT Demand	Max. PHPDT Capacity Available	Headway (min)	Rake Requirement		Total No of Rakes	No. of Cars per rake	No. of Cars
						Bare	Traffic Reserve			
Corridor 2: Vanaz - Ramvadi	13.79	31.0	6203	5170	12	5	1	7	4	28
Total Turn Round Time(min) 6										

Corridor 2: Vanaz - Ramvadi, Year : 2021
 Passenger Capacity @ 6 Persons/sqm in 4 Car Train: 1034
 Schedule Speed in Km/h = 31

Section	Distance (kms)	Schedule Speed in kmph	Projected PHPDT Demand	Max. PHPDT Capacity Available	Headway (min)	Rake Requirement		Total No of Rakes	No. of Cars per rake	No. of Cars
						Bare	Traffic Reserve			
Corridor 2: Vanaz - Ramvadi	13.79	31.0	8519	7755	8	8	1	10	4	40
Total Turn Round Time(min) 6										

Corridor 2: Vanaz - Ramvadi, Year : 2031
 Passenger Capacity @ 6 Persons/sqm in 4 Car Train: 1034
 Schedule Speed in Km/h = 31

Section	Distance (kms)	Schedule Speed in kmph	Projected PHPDT Demand	Max. PHPDT Capacity Available	Headway (min)	Rake Requirement		Total No of Rakes	No. of Cars per rake	No. of Cars
						Bare	Traffic Reserve			
Corridor 2: Vanaz - Ramvadi	13.79	31.0	10982	9545	6.5	10	1	12	4	48
Total Turn Round Time(min) 6										

Chapter - 7

Power Supply



- 7.1 Power Requirements
- 7.2 Need for High Reliability of Power Supply
- 7.3 Sources of Power Supply
- 7.4 Auxiliary Supply Arrangements for Stations & Depot
- 7.5 Electromagnetic Interference (EMI) and Electromagnetic Compatibility (EMC)
- 7.6 25 KV Rigid OHE System
- 7.7 25 KV Flexible OHE System
- 7.8 Rating of Major Equipment
- 7.9 Standby Diesel Generator (DG) Sets
- 7.10 Supervisory Control and Data Acquisition (SCADA) System
- 7.11 Energy Saving Measures
- 7.12 Electric Power Traffic



CHAPTER - 7

POWER SUPPLY ARRANGEMENT

7.1 POWER REQUIREMENTS

Electricity is required for operation of Metro system for running of trains, station services (e.g. lighting, lifts, escalators, signaling & telecom, fire fighting etc.) and workshops, depots & other maintenance infrastructure within premises of metro system. The power requirements of a metro system are determined by peak-hour demands of power for traction and auxiliary applications. Broad estimation of auxiliary and traction power demand is made based on the following requirements:-

- (i) Specific energy consumption of rolling stock – 70KWh/1000 GTKM
- (ii) Regeneration by rolling stock – 30%
- (iii) Elevated station load – initially 200KW, which will increase to 500 KW in the year 2031
- (iv) Underground Station load – initially 2000 kW, which will increase to 2500 KW in the year 2031
- (v) Depot auxiliary load - initially 1000KW, which will increase to 2000 KW in the year 2031

Keeping in view of the train operation plan and demand of auxiliary and traction power, power requirements projected for the year 2018, 2021 and 2031 are summarized in table 7.1 below:-

Table 7.1 - Power Demand Estimation (MVA)

Corridor		Year		
		2018	2021	2031
Corridor - 1 Pimpri Chinchwad -- Shivajinagar – Swar Gate. [16.59 km & 15 Stns. (6 U/G)].	Traction	6.8	7.6	7.6
	Auxiliary	18.9	20.0	26.6
	Total	25.7	27.6	34.2
Corridor - 2 Kothrud Depot (Vanaz) – Pune railway station – Ram Vadi. [14.93 kms& 16 Stns.].	Traction	2.8	3.6	4.2
	Auxiliary	5.2	7.3	11.7
	Total	8.0	10.9	15.9

Detailed calculations of power demand estimation are attached at **Annexure – 7.1 & 7.2.**

7.2 NEED FOR HIGH RELIABILITY OF POWER SUPPLY

The proposed Section of the Pune metro system is being designed to handle about 20,035 passengers per direction during peak hours when trains are expected to run at 3.5 minutes intervals in 2031. Incidences of any power interruption, apart from affecting train running, will cause congestion at stations. Interruption of power at night is likely to cause alarm and increased risk to traveling public. Lack of illumination at stations, non-visibility of appropriate signages, disruption of operation of lifts and escalators is likely to cause confusion, anxiety and ire in commuters, whose tolerance level are low on account of stress. Effect on signal and communication may affect train operation and passenger safety as well. Therefore, uninterrupted power supply is mandatory for efficient metro operations.

To ensure reliability of power supply, it is essential that both the sources of Supply and connected transmission & distribution networks are reliable and have adequate redundancies built in. Therefore, it is desirable to obtain power supply at high grid voltage of 220 or 132V from stable grid sub-stations and further transmission & distribution is done by the Metro Authority itself.

7.3 SOURCES OF POWER SUPPLY

The high voltage power supply network of Pune city has 220kV and 132kV and network to cater to various types of demand in vicinity of the proposed corridor. 220 kV Sub Stations are generally located at outskirts of the city. 220/132 kV sub stations and some 132 KV Transmission lines are located /passing near to the alignment of Corridors. Keeping in view the reliability requirements, two input sources of 132 kV Voltage level are normally considered for each corridor. Accordingly, two Receiving Sub Stations (132 / 33/25 kV) are proposed to be set up for Corridor I & Corridor –II each. Based on the discussions with Pune power supply authorities, it is proposed to avail power supply for traction as well as auxiliary services from the following grid sub-stations at 132 kV voltage through double cable feeders. The input sources for these four grid sub stations are different therefore the reliability enhances further: Sources of power supply is given in Table 7.2.

Table 7.2 - Sources of Power Supply

Corridor	Grid sub-station (with Input voltage)	Location of RSS of Metro Authority	Approx. length of cables
Corridor – I PimpriChinchwad – Shivajinagar – Swar Gate.	Chinchwad GSS (220 / 132kV)	Near PCMC (132 / 33/25 kV).	5km. 132kV (Double Circuit cables).
	Ganesh Khind Grid Sub Station (220 / 132 kV).	RSS near Agriculture College (132 / 33/25 kV)	2.5km. 132kV (Double Circuit cables).
Corridor – II Kothrud Depot (Vanaz) –Pune railway station- Ram Vadi.	BY LILO From 132 KV transmission line at Kothrud	Near Kachara Depot (132 / 33/25 kV)	2.5 km. 132kV (Double Circuit Cables).
	Khardi Grid Sub Station (220 / 132 kV).	Near Ram Vadi (132 / 33/25 kV)	3 km. 132kV (Double Circuit Cables).

Summary of expected power demand at various sources is given in Table – 7.3. Maharashtra state Electricity Distribution Co. Ltd. have confirmed availability of requisite power at their above sub-stations vide letter No CE/PZ/T/Pune Metro Rail Project/327dated:-01.09.2008 (**Annexure 7.3**).

Table 7.3 - Power Demand Projection for various sources

Corridor	Input Source	Peak Demand – Normal (MVA)		Peak Demand – Emergency (MVA)	
		2018	2031	2018	2031
Corridor – I PimpriChinchwad – Shivajinagar – Swar Gate	RSS Near PCMC office				
	Traction	3.8	4.3	6.8	7.6
	Auxiliary	2.2	5.6	18.9	26.6
	Sub – Total (A)	6.0	9.9	25.7	34.2
	RSS near Agriculture College				
	Traction	3.0	3.3	6.8	7.6
	Auxiliary	16.7	21.0	18.9	26.6
	Sub – Total (B)	19.7	24.3	25.7	34.2
	TOTAL (A + B)	25.7	34.2		
Corridor – II Kothrud Depot (Vanaz) –Pune railway station- Ram Vadi.	RSS near Kachara Depot				
	Traction	2.0	2.7	2.8	4.2
	Auxiliary	3.2	6.8	5.2	11.7
	Total	5.2	9.5	8.0	15.9
	RSS Near Ramvadi				
	Traction	0.8	1.5	2.8	4.2
	Auxiliary	2.0	4.9	5.2	11.7
	Total	2.8	6.4	8.0	15.9
	TOTAL (A + B)	8.0	15.9		

The 132 kV power supply will be stepped down to 25kV single phase for traction purpose at the RSS of Pune Metro and the 25kV traction supply will be fed to the OHE at viaduct through cable feeders. For feeding the auxiliary loads, the 132kV power supply received will be stepped down to 33 kV and will be distributed along the alignment through 33kV Ring main cable network. These cables will be laid in dedicated ducts along the viaduct / on tunnel walls. If one RSS trips on fault or input supply failure, train services can be maintained from the other RSS. However, in case of total grid failure, all trains may come to a halt but station lighting & other essential services can be catered to by stand-by DG sets. Therefore, while the proposed scheme is expected to ensure adequate reliability, it would cater to emergency situations as well.



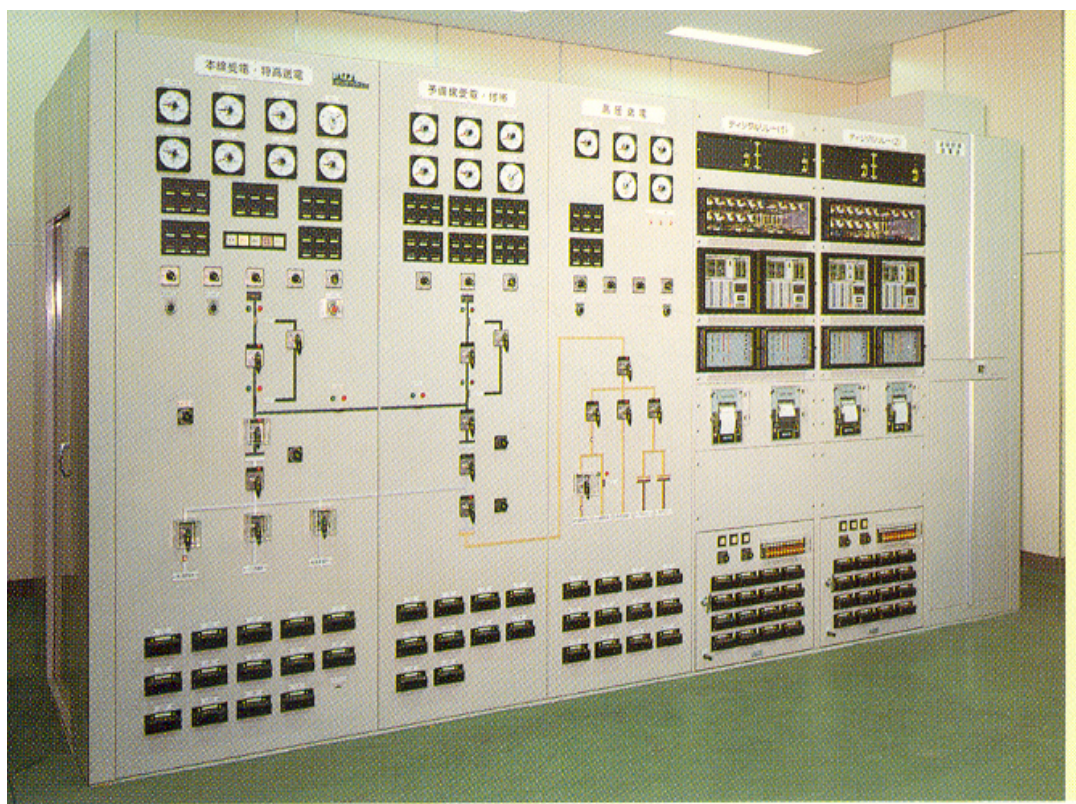
Typical High Voltage Receiving Sub-Station

The 132kV cables will be laid through public pathways from Maharashtra State Electricity Distribution Co. Ltd. Sub-stations to RSS of Metro Authority. For corridor-I, RSS Near PCMC and near Agriculture College shall be provided with 2nos. (one as standby) 132/25 kV, 10 MVA single-phase traction Transformers for feeding Traction and 132/33 KV, 30 MVA three phase Transformers for feeding auxiliary loads. For corridor – II, RSS Near Kachara depot and RSS near Ramvadi shall be provided with 2nos. (one as standby) 132/25 kV, 10 MVA single phase traction Transformers for feeding Traction supply and 132/33 KV, 15 MVA three phase Transformers for feeding auxiliary loads. The capacity of transformers may be reviewed considering the load requirement/distribution of both the corridors at the time of detailed design.

Conventional Outdoor type 132 kV Switchgear is proposed for above Four RSS's to be located in approx. 100 X 60 m (6000 sq. mm) land plot, as the availability of Land in this area may not be a constraint.

7.4 AUXILIARY SUPPLY ARRANGEMENTS FOR STATIONS & DEPOT

Auxiliary sub-stations (ASS) are envisaged to be provided at each station (3 ASS's for Underground stations and 1 ASS for elevated station) for stepping down 33 kV supply to 415 V for auxiliary applications. A separate ASS is required at depot. The ASS will be located at mezzanine or platform level inside a room. The auxiliary load requirements have been assessed at 200kW for elevated / at-grade stations which is likely to increase up to 500 KW in the year 2031 and 2000 kW for Underground Station which is likely to increase up to 2500 KW in the year 2031. In order to meet the requirement of auxiliary power two dry type cast resin transformers (33/0.415kV) of 500kVA capacity are proposed to be installed at the elevated stations (one transformer as standby) and one transformer of 1.6 MVA at each underground ASS. For Property Development within the footprints of the station, a provision to add third transformer at a later date may be kept at elevated station



Typical Indoor Auxiliary Sub-station

7.5 ELECTROMAGNETIC INTERFERENCE (EMI)

AND ELECTROMAGNETIC COMPATIBILITY (EMC)

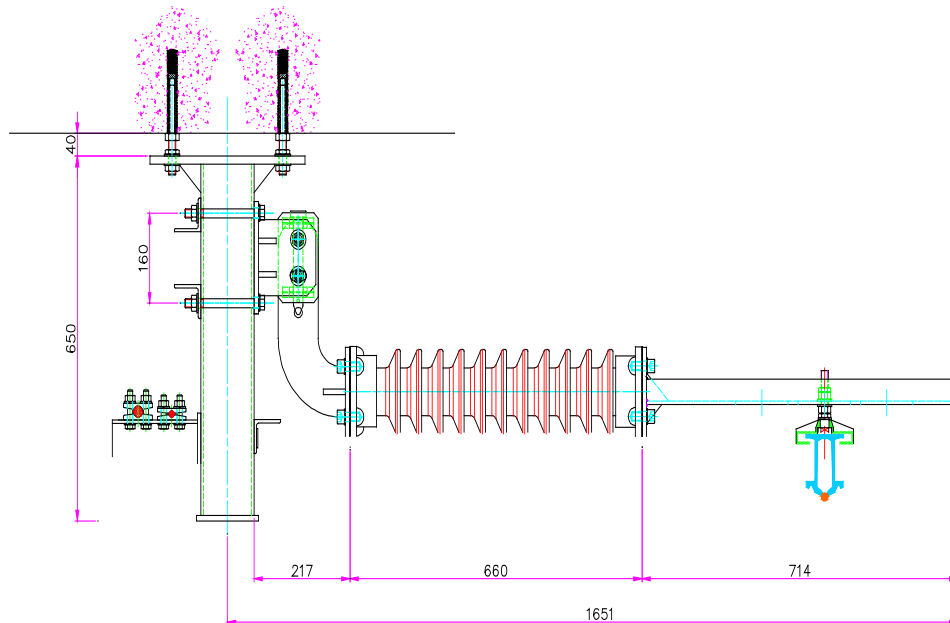
25kV ac traction currents produce alternating magnetic fields that cause voltages to be induced in any conductor running along the track. Booster Transformer and Return Conductor (BT/RC) System is proposed for EMI mitigation. Concrete structures of elevated viaducts are not good electrical earths and therefore, Earthing and Bonding of the traction system shall be in accordance with the latest standards EN50122-1, IEEE80 and other relevant standards. Two earth conductors –Overhead Protection Cable (OPC) and Buried Earth Conductor (BEC) are proposed to be laid along with elevated via duct and all the metallic structures, structural reinforcement, running rails etc will be connected to these conductors to form an equiv-potential surface & a least resistance path to the fault currents. The overhead protection cable will also provide protection against lightning to the 25kV OHE and the elevated viaduct. Similar arrangements have been adopted on Delhi Metro as well.

Detailed specification of equipment e.g. power cables, transformer, switchgear, E&M equipment etc shall be framed to reduce conducted or radiated emissions as per appropriate international standards. The Metro system as a whole (trains, signaling & telecomm, traction power supply, E&M system etc) shall comply with the EMC requirements of international standards viz. EN50121, EN50123, IEC61000 series etc. A detailed EMI/EMC plan will be required to be developed during project implementation stage.

7.6 25 kV RIGID OHE SYSTEM

The proposed 25kV Rigid OHE system in underground section is similar to the one installed in underground Metro Corridor of Delhi Metro. 25kV Rigid OHE system comprises a hollow Aluminum Conductor Rail of adequate cross section with 107 sqmm copper contact wire held with elastic pinch. The Al conductor rail is supported by an insulator & cantilever arrangement attached to drop-down supports fixed to tunnel roof. The supports are located at every 10metre and there is no tension in the conductors and hence, no tensioning equipment in tunnel. The design of 25kv rigid OHE system shall be in accordance to electrical clearances & contact wire height as per IEC 60913, which is summarized below:

- | | |
|--|---------------|
| a) Contact wire height | 4570mm |
| b) Structure to Live parts clearances
(Static/Dynamic/Absolute min dynamic) | 270/170/150mm |
| c) Vehicle to Live parts clearances
(Static/Dynamic/Absolute min dynamic) | 290/190/150mm |



25kV Rigid OHE Arrangement

7.7 25KV FLEXIBLE OVERHEAD EQUIPMENT (OHE) SYSTEM

25kV ac flexible OHE system shall comprise 107 sqmm HD-copper contact wire and 65 sqmm Cd-copper catenary wire. Return conductor (RC) shall be All Aluminum Conductor (AAC) of 233sqmm cross section. From safety considerations, Hydraulic type Anti-Tensioning Device (ATDs) are proposed on mainlines which does not require use of balance weight for tensioning of OHE conductors. Proven catenary fittings are proposed similar to DMRC system.

7.8 RATING OF MAJOR EQUIPMENT

25kV ac Overhead Equipment (OHE) shall comprise 107mm² HD-copper contact wire and 65 mm² Cd-copper catenary wire. Return conductor (RC) shall be All Aluminum Conductor (AAC) of 233 mm² cross section. From safety considerations, Hydraulic type Anti-Tensioning Device (ATDs) are proposed on mainlines which does not require use of balance weight for tensioning of OHE conductors.

Based on emergency demand expected at each RSS as shown in Table 6.3, 2 nos. 132/25kV traction transformers of 10 MVA capacity and 2 nos. 30 MVA capacity Auxiliary

transformers shall be provided at each RSS in Corridor -I. and 2 nos. 132/25kV traction transformers of 10 MVA capacity and 2 nos. 15 MVA capacity Auxiliary transformers shall be provided at each RSS in Corridor -II, being standard design (one to be in service and second one to serve as standby). The 132kV incoming cable shall be 3-phase single core XLPE insulated with 630 mm² Aluminum conductor to meet the normal & emergency loading requirements and fault level of the 132 kV supply.

33kV and 25kV switchgear shall be rated for 1250 A being standard design. 33kV cable ring network shall be adequately rated to transfer requisite auxiliary power during normal as well as emergency situations and accordingly 3 number of Single core 300 mm² XLPE insulated 33kV cable is proposed for ring main network. [FRLSOH Copper conductor cable for Corridor 1 with underground section and FRLS Aluminum conductor Cable for Corridor 2 with fully Elevated section].

Adequate no. of cables are required for transfer of traction power from Metro's RSS to 25kV OHE. Single-phase XLPE insulated cables with 240mm² copper conductor are proposed for traction power. Based on current requirements, 2 cables are required for each of the two circuits to feed power to OHE.

The above capacities of transformers, switchgear, cables etc. have been worked out based on the conceptual design. Therefore, these may be required to be revised for better accuracy during design stage of project implementation.

7.9 STANDBY DIESEL GENERATOR (DG) SETS

In the unlikely event of simultaneous tripping of all the input power sources or grid failure, the power supply to stations as well as to trains will be interrupted. It is, therefore, proposed to provide a standby DG set of 200 KVA capacity at the elevated stations and 2 X 1000/750 KVA at Underground stations to cater to the following essential services:

- (i) Essential lighting
- (ii) Signaling & telecommunications
- (iii) Fire fighting system
- (iv) Lift operation
- (v) Fare collection system
- (vi) Tunnel Ventilation (for Underground Stations)

Silent type DG sets with low noise levels are proposed, which do not require a separate room for installation.

7.10 SUPERVISORY CONTROL AND DATA ACQUISITION (SCADA) SYSTEM

The entire system of power supply (receiving, traction & auxiliary supply) shall be monitored and controlled from a centralized Operation Control Centre (OCC) through SCADA system. Modern SCADA system with intelligent remote terminal units (RTUs) shall be provided. Optical fibre provided for telecommunications will be used as communication carrier for SCADA system.

Digital Protection Control System (DPCS) is proposed for providing data acquisition, data processing, overall protection control, interlocking, inter-tripping and monitoring of the entire power supply system consisting of 33kV ac switchgear, transformers, 25kV ac switchgear and associated electrical equipment. DPCS will utilize microprocessor-based fast-acting numerical relays & Programmable Logic Controllers (PLCs) with suitable interface with SCADA system

7.11 ENERGY SAVING MEASURES

Energy charges of any metro system constitute a substantial portion of its operation & maintenance (O & M) costs. Therefore, it is imperative to incorporate energy saving measures in the system design itself. The auxiliary power consumption of metros is generally more than the traction energy consumed by train movement during initial years of operation. Subsequently, traction power consumption increases with increase in train frequency/composition in order to cater more traffic. The proposed system of Pune Metro includes the following energy saving features:

- (i) Modern rolling stock with 3-phase VVVF drive and lightweight stainless steel coaches has been proposed, which has the benefits of low specific energy consumption and almost unity power factor.
- (ii) Rolling stock has regeneration features and it is expected that 30% of total traction energy will be regenerated and fed back to 25kV ac OHE to be consumed by nearby trains.
- (iii) Effective utilization of natural light is proposed. In addition, the lighting system of the stations will be provided with different circuits (33%, 66% & 100%) and the relevant circuits can be switched on based on the requirements (day or night, operation or maintenance hours etc).
- (iv) Machine-room less type lifts with gearless drive have been proposed with 3-phase VVVF drive. These lifts are highly energy efficient.
- (v) The proposed heavy-duty public services escalators will be provided with 3-phase VVVF drive, which is energy efficient & improves the power factor. Further, the

escalators will be provided with infrared sensors to automatically reduce the speed (to idling speed) when not being used by passengers.

- (vi) The latest states of art and energy efficient electrical equipment (e.g. transformers, motors, light fittings etc) have been incorporated in the system design.
- (vii) Efficient energy management is possible with proposed modern SCADA system by way of maximum demand (MD) and power factor control.

7.12 ELECTRIC POWER TARIFF

The cost of electricity is a significant part of Operation & Maintenance (O&M) charges of the Metro System, which constitutes about 25-35% of total annual working cost. Therefore, it is the key element for the financial viability of the Project. The annual energy consumption is assessed to be about 69.2million units in initial years (2018), which will increase to 90.1 Million Unitsby year 2031 for Corridor – 1 and about 20.4million units in initial years (2018), which will increase to 43.9 Million Unitsby year 2031 for Corridor – 2. In addition to ensuring optimum energy consumption, it is also necessary that the electric power tariff be kept at a minimum in order to contain the O& M costs. Therefore, the power tariff for this Corridor should be at effective rate of purchase price (at 132 kV voltage level) plus nominal administrative charges i.e. on a no profit no loss basis. This is expected to be in the range of Rs. 2.50-2.75 per unit. It is proposed that Government of Maharashtra take necessary steps to fix power tariff for Pune Metro at “No Profit No Loss” basis. Financial analysis has been carried out based on this tariff for the purpose of finalizing the DPR. Similar approach is being pursued for Delhi Metro.

ANNEXURE 7.1

POWER REQUIREMENTS	Year 2018		Year 2021		Year 2031	
Corridor-1: Pimpri Chinchwad to swargate						
Traction power requirements						
Tare weight of 4 Car train	156	T	156	T	156	T
Passenger carrying capacity of 4 Car Train	1034	T	1034	T	1034	T
No of cars	4	(2DTC+2MC)	4	(2DTC+2MC)	4	(2DTC+2MC)
Passenger weight	67.2	T	67.2	T	67.2	T
Total Train weight	223.2	T	223.2	T	223.2	T
Section length	15.69	KM	15.69	KM	15.69	KM
Headway	4	mts	3.5	mts	3.5	mts
Specific Energy consumption	70	KW/hr/1000G TKM	70	KW/hr/1000GTKM	70	KW/hr/1000GTKM
No. of trains/hr in both directions	30		34.29		34.29	
Peak traction power requirement	7.4	MW	8.4	MW	8.4	MW
Less Regeneration @30%	2.2	MW	2.5	MW	2.5	MW
Depot power requirements	1.0	MW	1.0	MW	1.0	MW
Total traction power requirement	6.1	MW	6.9	MW	6.9	MW
Total traction power requirement (MVA) assuming 5% energy losses and 0.95 pf	6.8	MVA	7.6	MVA	7.6	MVA
Station aux power requirements						
Elevated/at-grade station--power consumption	0.20	MW	0.30	MW	0.50	MW
Underground station--power consumption	2.00	MW	2.00	MW	2.50	MW
No. of elevated/at-grade stations	9		9		9	
No. of underground stations	6		6		6	

POWER REQUIREMENTS	Year 2018		Year 2021		Year 2031	
Total Station Aux Power requirement	13.8	MW	14.7	MW	19.5	MW
Depot Aux power requirement	1.5	MW	1.5	MW	2.0	MW
Total Aux Power requirement	15.3	MW	16.2	MW	21.5	MW
Total aux power requirement (MVA) assuming 5% energy losses and 0.85 pf	18.9	MVA	20.0	MVA	26.6	MVA
Total traction & aux power requirement	25.7	MVA	27.6	MVA	34.2	MVA
Corridor-2 :Vanaz to Ramvadi						
Traction power requirements						
Tare weight of 4 Car train	156	T	156	T	156	T
Passenger carrying capacity of 4 Car Train	1034	T	1034	T	1034	T
No of cars	4	(2DTC+2MC)	4	(2DTC+2MC)	4	(2DTC+2MC)
Passenger weight	67.2	T	67.2	T	67.2	T
Total Train weight	223.2	T	223.2	T	223.2	T
Section length	13.79	KM	13.79	KM	13.79	KM
Headway	12	mts	8	mts	6.5	mts
Specific Energy consumption	70	KWhr/1000G TKM	70	KWhr/1000GTKM	70	KWhr/1000GTKM
No. of trains/hr in both directions	10		15		18.5	
Peak traction power requirement	2.2	MW	3.2	MW	4.0	MW
Less Regeneration @30%	0.6	MW	1.0	MW	1.2	MW
Depot power requirements	1.0	MW	1.0	MW	1.0	MW
Total traction power requirement	2.5	MW	3.3	MW	3.8	MW
Total traction power requirement (MVA) assuming 5% energy losses and 0.95 pf	2.8	MVA	3.6	MVA	4.2	MVA

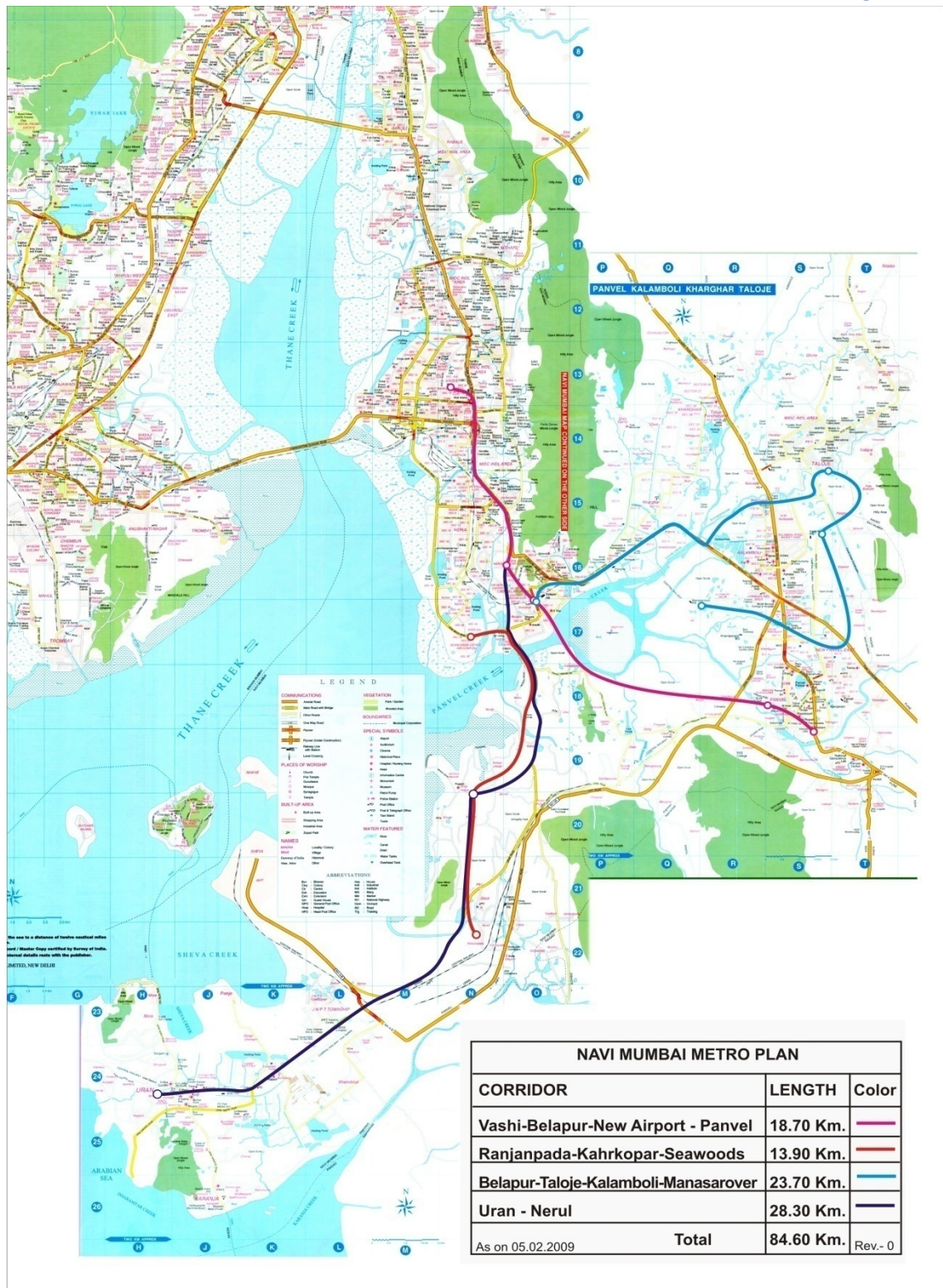
POWER REQUIREMENTS	Year 2018		Year 2021		Year 2031	
Station aux power requirements						
Elevated/at-grade station--power consumption	0.20	MW	0.30	MW	0.50	MW
Underground station--power consumption	2.0	MW	2.0	MW	2.50	MW
No. of elevated/at-grade stations	16		16		16	
No. of Underground stations	0		0		0	
Total Station Aux Power requirement	3.2	MW	4.8	MW	8.0	MW
Depot Aux power requirement	1.0	MW	1.1	MW	1.5	MW
Total Aux Power requirement	4.2	MW	5.9	MW	9.5	MW
Total aux power requirement (MVA) assuming 5% energy losses and 0.85 pf	5.2	MVA	7.3	MVA	11.7	MVA
Total traction & aux power requirement	8.0	MVA	10.9	MVA	15.9	MVA

ENERGY REQUIREMENTS						
Pimpri Chinchwad to Swargate						
	Year 2018		Year 2021		Year 2031	
Traction power requirements						
No of cars	4	(2MC+2 DTC)	4	(2MC+2 DTC)	4	(2MC+2 DTC)
Passenger weight	67.2	T	67.2	T	67.2	T
Train Tare weight	156.0	T	156.0	T	156.0	T
Total train weight	223.2	T	223.2	T	223.2	T
Section length	15.69	KM	15.69	KM	15.69	KM
Specific Energy consumption with 30% regeneration	49	KW/hr/1 000 GTKM	49	KW/hr/1 000 GTKM	49	KW/hr/1 000 GTKM
No. of trains per direction in a day	178		193		193	
Yearly Traction Energy consumption with 365 days working with 30% regen	22.30	million units	24.18	million units	24.18	million units
Station aux power requirements						
Elevated/at-grade station--power consumption	0.20	MW	0.30	MW	0.50	MW
Underground station--power consumption	2.00	MW	2.00	MW	2.50	MW
Underground Mid-shaft power	0.30	MW	0.30	MW	0.30	MW
No.of Mid-Shaft	0		0		0	
No. of elevated/at-grade stations	9		9		9	
No. of Underground stations	6		6		6	
Total Station Aux Power requirement	13.8	MW	14.7	MW	19.5	MW
Depot Aux power requirement	1.5	MW	1.50	MW	2.00	MW
Total Aux Power requirement	15.3	MW	16.2	MW	21.5	MW
Total aux power requirement (MVA) assuming 5% energy losses and .85 pf for aux loads	18.9	MVA	20.0	MVA	26.6	MVA
Diversity factor of aux loads	0.4		0.4		0.4	
Yearly Aux Energy consumption 20 hrs/day and 365 days working (million units)	46.91	million units	49.67	million units	65.92	million units
Net Annual Energy Consumption (Traction & Aux)	69.2	million units	73.8	million units	90.1	million units

Note:- The requirement of PD load is not considering in estimation of power calculation.

ENERGY REQUIREMENTS						
Vanaz to Ramvadi						
	Year 2018		Year 2021		Year 2031	
Traction power requirements						
No of cars	4	(2MC+2 DTC)	4	(2MC+2 DTC)	4	(2MC+2 DTC)
Passenger weight	67.2	T	67.2	T	67.2	T
Train Tare weight	156.0	T	156.0	T	156.0	T
Total train weight	223.2	T	223.2	T	223.2	T
Section length	13.79	KM	13.79	KM	13.79	KM
Specific Energy consumption with 30% regeneration	49	KW/hr/1 000 GTKM	49	KW/hr/1 000 GTKM	49	KW/hr/1 000 GTKM
No. of trains per direction in a day	68		89		135	
Yearly Traction Energy consumption with 365 days working with 30% regen	7.49	million units	9.80	million units	14.86	million units
Station aux power requirements						
Elevated/at-grade station--power consumption	0.20	MW	0.30	MW	0.50	MW
Underground station--power consumption	2.00	MW	2.00	MW	2.50	MW
Underground Mid-shaft power	0.30	MW	0.30	MW	0.30	MW
No.of Mid-Shaft	0		0		0	
No. of elevated/at-grade stations	16		16		16	
No. of Underground stations	0		0		0	
Total Station Aux Power requirement	3.2	MW	4.8	MW	8.0	MW
Depot Aux power requirement	1.0	MW	1.1	MW	1.5	MW
Total Aux Power requirement	4.2	MW	5.9	MW	9.5	MW
Total aux power requirement (MVA) assuming 5% energy losses and .85 pf for aux loads	5.2	MVA	7.3	MVA	11.7	MVA
Diversity factor of aux loads	0.4		0.4		0.4	
Yearly Aux Energy consumption 20 hrs/day and 365 days working (million units)	12.88	million units	18.09	million units	29.13	million units
Net Annual Energy Consumption (Traction & Aux)	20.4	million units	27.9	million units	44.0	million units

Note:- The requirement of PD load is not considering in estimation of power calculation.



ANNEXURE 7.3

Annexure – 6.3



महामिटरान
1st floor, Adm. Bldg., Rastapeth, Pune-411011.
Phone NO.020-26137244/45/46
No. CE/PZ/ T/Pune Metro Rail Project/327 Date: 01.09.2008

Minutes Of Meeting

Sub: - Power supply requirement & sources to Pune Metro Rail Projects.

Ref: - 1) Letter from M/s Delhi Metro Rail Corporation Ltd.
L. No. DMRC/Hect/P19/Pune/25239 dtd. 22.08.08.
2) Joint site Visit & Meeting on dtd. 27.08.08.

A meeting was held dtd. 27.08.08 with MSEDCL & MSETCL Officials and representative of M/s Delhi Metro Rail Corporation Ltd. for discuss the issues regarding power supply requirement and sources to Pune Metro Rail Project.

The following officials were present for joint survey and meeting.

MSETCL Officials

- 1) Ms. V. I. Mukhedkar – SE, Trans O&M under charge of CE,
- 2) Mr. R. L. Gaikwad – EE, MSS Dn. Pune under Charge of SE, EHV, Const. Circle Pune
- 3) Ms. R. S. Joshi – EE, EHV, Const- O&M Zone Pune.
- 4) Mr. K. D. Deshmukh – EE, EHV, TL O&M Division, Pune
- 5) Mr. N. K. Bhise – EE, EHV, RSS, Division, Pune.

MSEDCL Officials

- 1) Mr. S. D. Rajdeep – EE, Pune Zone.
- 2) Mr. S. R. Pawade – EE, Kothrud Division.
- 3) Mr. I. A. Mulani – EE, Pimpri Division.
- 4) Mr. K. N. Jamdade – AE, Pune Zone.

Delhi Metro Corporation Ltd.

- 1) Ms. Swapnagandha Ghangurde – Representative of DMRC Ltd.

The Ex. Engineer, PZ greeted all the officials and after introduction of each the following issues were discussed:

The Ex. Engineer, PZ informed that the total power requirement by M/s DMRC Ltd. is 31.5 MVA for two corridor of Pune Metro Rail Project as below:

- Corridor-1: Pimpri Chinchwad to Swargate (approximate length of 16.5 Kms) via Agricultural College and Shivaji Nagar Station.
- Corridor-2: PMC Depot to Ram Vadi (approximate length of 14 Kms) via Deccan Gymkhana and Civil Court.

Further it is also informed that, for above 2 corridor, they requires power supply at 2 locations for each on 132/220 KV EHV level. The locations are as below:

For Corridor 1:

- 1) Chinchwad (Nr to PCMC office)
- 2) Ganesh Khind (Nr to Agricultural College)

For Corridor 2:

- 1) Kothrud (at Kachara Depot)
- 2) Kharadi (Nr Ram Vadi)

The technical feasibility for erection of EHV sub station by Pune Metro Rail Project is discussed with MSETCL Officials and details are as below:

It is informed by MSETCL Officials that LILLO arrangement to above four locations for erection of EHV sub station is not possible in view of crucial lines of Pune City. The EHV supply can be available for above 4 locations is as below:

- a) Chinchwad: By laying EHV line from Chinchwad EHV sub station. Approx. route length from 132 KV Chinchwad EHV sub station to PCMC office is 5 Kms.
- b) Ganesh Khind: 132 KV EHV supply can be available within two years from 132 KV Ganesh Khind EHV sub station. Approx. route length from 132 KV Ganesh Khind EHV sub station to Agricultural College is 2.5 Kms.
- c) Kothrud: There is no space available at 132 KV Kothrud sub station for erection of Bays therefore it is informed by MSETCL Officials that if DMRC is ready to spare the land admeasuring 100 mtr X 100 mtr to MSETCL for erection of 132 KV EHV sub station then MSETCL can make the arrangement to give power supply on 132 KV level to DMRC's EHV sub station at Kachara Depot Kothrud.
- d) Kharadi: By laying EHV line from Kharadi EHV sub station. Approx. route length from 132 KV Kharadi EHV sub station to Ram Vadi is 3 Kms.

It is informed by DMRC Ltd that the land for erection of EHV sub station will be finalized by them in co-ordination with PMC & PCMC Pune.

The two sites i.e. Agricultural College, Second is Kachara Depot. were visited with above all Officials.

It was confirmed in the meeting that all works would be executed by Pune Metro Rail Project at their own cost.

The meeting concludes with vote of thanks.


Executive Engineer -II, PZ

Copy s.w.rs.to:

The Chief Engineer, EHV, Const. O&M, Zone Pune.
The SE, MSETCL, EHV, Const. Circle / Trans O & M, Circle Pune.
The SE, MSEDCL, RPUC/GKUC, Pune.

Copy to:

The Ex. Engineer, MSETCL, EHV, Const- O&M Zone / TL O&M Dn./ MSS Dn./ RSS Dn. Pune.
The Ex. Engineer, MSEDCL, Kothrud Dn. / Pimpri Dn. /Pune

CC to:

✓ The Ex. Director/ Elect. Delhi Metro Rail Corporation Ltd.,
N.B.C.C. Place, Bhisma Pitamah Marg,
Pragati Vihar, New Delhi- 110003.

Copy to:

Steno (PZ), Pune. for appraisal of the CE PZ, Pune.

Chapter - 8

Ventilation & Air Conditioning System



- 8.1 Introduction
- 8.2 Alignment Ventilation & Air Conditioning
- 8.3 Need for Ventilation & Air Conditioning
- 8.4 External Environment Conditions & Weather Data
- 8.5 Sub Soil Temperature
- 8.6 Internal Design Conditions in Underground Station
- 8.7 Design Parameters for VAC System
- 8.8 Design Concepts for VAC System
- 8.9 Trackway Exhaust System
- 8.10 Tunnel Ventilation System
- 8.11 Pressure Transients
- 8.12 Ventilation & Air Conditioning of Ancillary Spaces
- 8.13 Station Smoke Management System
- 8.14 Control & Monitoring Facilities
- 8.15 Codes & Standards



CHAPTER -8

VENTILATION AND AIR-CONDITIONING SYSTEM

8.1 INTRODUCTION

This chapter covers the Ventilation and Air-conditioning (VAC) system requirements for the underground sections of the proposed Metro Rail Project Pune Metropolitan area. It includes the following:

- Station Air-conditioning System
- Ventilation System for station plant rooms (ancillary spaces)
- Station Smoke Management System
- Tunnel Ventilation System

8.2 ALIGNMENT

The proposed alignment has an underground section of about 4.5 km. This would include 5 underground stations and 3 tunnel portals.

The MRTS alignment passes through the heart of the city. The underground section starts from tunnel portal between Hill Range and Shivaji Nagar station and passes through ASI U/G station. The alignment goes to PMC elevated station and starts underground again from tunnel portal between PMC and Budhwar Peth station and passes through Mandai and Swargate U/G Metro Stations. The route terminates in underground dead end. The inter-station distances vary from 675 m to 1604 meters.

8.3 NEED FOR VENTILATION AND AIR CONDITIONING

The underground stations of the Metro Corridor are built in a confined space. A large number of passengers occupy concourse halls and the platforms, especially at the peak hours. The platform and concourse areas have a limited access from outside and do not have natural ventilation. It is therefore, essential to provide forced ventilation in the stations and inside the tunnel for the purpose of:

- Supplying fresh air for the physiological needs of passengers and the authority's staff;
- Removing body heat, obnoxious odours and harmful gases like carbon dioxide exhaled during breathing;
- Preventing concentration of moisture generated by body sweat and seepage of water in the sub-way;
- Removing large quantity of heat dissipated by the train equipment like traction motors, braking units, compressors mounted below the under-frame, lights and fans inside the coaches, A/c units etc.;
- Removing vapour and fumes from the battery and heat emitted by light fittings, water coolers, Escalators, Fare Gates etc. working in the stations;
- Removing heat from air conditioning plant and sub-station and other equipment, if provided inside the underground station.

This large quantity of heat generated in M.R.T. underground stations cannot be extracted by simple ventilation, especially when the outdoor air temperature and humidity is high. It is, therefore, essential to provide mechanical cooling in order to remove the heat to the maximum possible extent. As the passengers stay in the stations only for short periods, a fair degree of comfort conditions are considered appropriate. In winter months it may not be necessary to cool the ventilating air as the heat generated within the station premises would be sufficient to maintain the comfort requirement.

8.4 EXTERNAL ENVIRONMENT CONDITIONS AND WEATHER DATA

The design weather data from the ASHRAE handbooks have been used to arrive at the design criteria. Based on the feedback and analysis of the VAC system installed at Delhi Metro, it is suggested that 2% criteria would be acceptable on techno economic reasons. The climate pattern in Pune suggests that the summer season is generally between March to June. During the July and February months the weather generally has temperate conditions. The air pollution of Pune throughout the year adds new dimension and there is a critical need for maintaining desired Air – Quality (Environmental control) in public places like MRT stations. High content of suspended particles, Carbon Mono-oxide, Sulphur Dioxide etc. discharged in the air from moving traffic, industries, etc requires consideration of appropriate measures for air -pollution control in metro stations, while designing the VAC system.

8.5 SUB-SOIL TEMPERATURE

The temperature conditions of sub-soil play a vital role in the system design of the underground stations. It is also expected that water table surrounding the underground alignment is not very much below the surface level, thereby facilitating adequate heat exchange between the tunnel structures and soil.

8.6 INTERNAL DESIGN CONDITIONS IN UNDERGROUND STATIONS

With hot and humid ambient conditions of Pune during the summer and monsoon months, it is essential to maintain appropriate conditions in the underground stations in order to provide a 'comfort-like' and pollution-free environment. The plant capacity and design of VAC system needs to be optimized for the designed inside conditions.

The Indian Standards & Codes, which pertain to office-buildings, commercial centers and other public utility buildings, have no guidelines on temperature standards to be maintained for the underground mass rapid transit systems as yet. The standards used for buildings cannot be applied straightaway for the underground spaces, because the patrons will stay for much shorter durations in these underground stations.

The comfort of a person depends on rapidity of dissipation of his body heat, which in turn depends on temperature, humidity and motion of air in contact with the body. Body heat gets dissipated is given out by the process of evaporation, convection and conduction. Evaporation prevails at high temperature. Greater proportion of heat is dissipated by evaporation from the skin, which gets promoted by low humidity of air. The movement of air determines the rate of dissipation of body heat in the form of sensible and latent heat.

There are different comfort indices recognized for this purpose. The 'Effective Temperature' criterion was used in selecting the comfort conditions in earlier metro systems, including the north-south section of Kolkata Metro. In this criterion, comfort is defined as the function of temperature and the air velocity experienced by a person. More recently a new index named RWI (Relative Warmth Index) has been adopted for metro designs worldwide. This index depends upon the transient conditions of the metabolic rate and is evaluated based on the changes to the surrounding ambience of a person in a short period of about 6 to 8 minutes. It is assumed that during this period human body adjusts its metabolic activities. Therefore in a subway system where the train headway is expected to be six minutes or less, RWI is the preferred criterion.

8.7 DESIGN PARAMETERS FOR VAC SYSTEM

Based on the reasons stated in the previous sections. The following VAC system design parameters are assumed in the present report.

(1) Outside ambient conditions:

This is based upon ASHRAE recommended design conditions for 2% and 1% criteria, as under:-

	<u>2% Criteria</u>	<u>1% Criteria</u>
Summer :	35.9 DB, 19.6 WB	37.0 DB, 19.6 WB
Monsoon :	28.2 DB, 23.7 WB	28.8 DB, 24.1 WB

For Pune Metro Underground Corridor it is suggested to use 2% criteria, which is defined as the conditions, when the DB or WB temperatures are likely to exceed for only 2% of the total time.

(2) Inside design conditions:

Platform areas	-	25 deg. C at 55 % RH
Concourse	-	26 deg. C at 60% RH

(3) Tunnel design conditions:

Normal conditions	-	Max. DB 40 deg. C
Congested conditions	-	Max. DB 45 deg. C

(4) Minimum fresh air

(in station public areas)	-	10 % or 18 cmh/person
---------------------------	---	-----------------------

8.8 DESIGN CONCEPTS FOR VAC SYSTEM

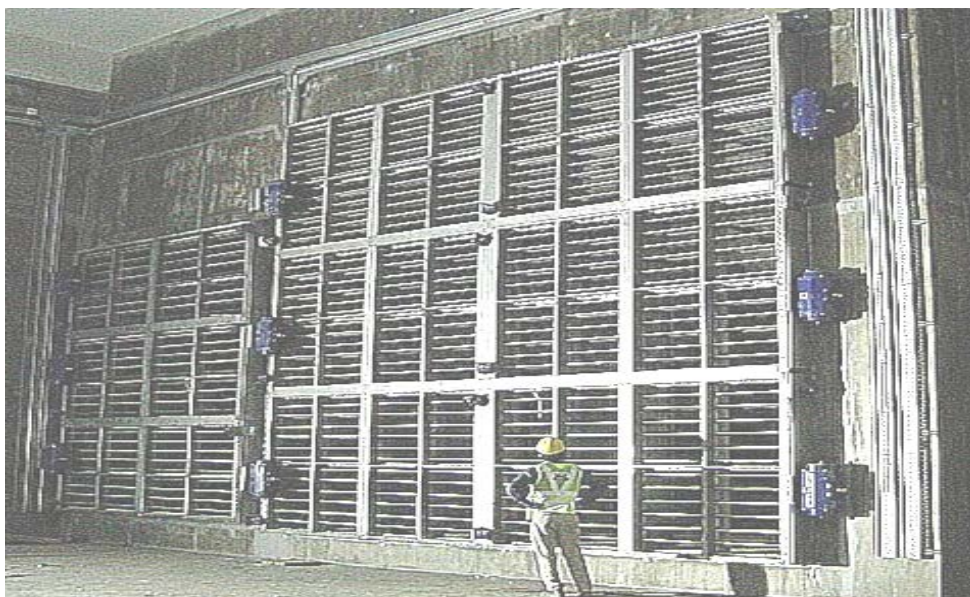
There are various VAC design concepts technically feasible in a subway system that can provide and maintain acceptable subway environment conditions under different requirement and constraints. These are: Open type; Closed type; Mid - Tunnel Cooling; Semi Transverse Ventilation; Use of jet fans; use of mid-shafts; platform screen doors etc. An overview of VAC systems in other metros like Jubilee line extension, Bangkok etc. that have similar climatic behavior and ambient conditions have provided valuable information in deciding VAC concept for Pune Metro Underground Corridor. The experience available from the design of VAC system for Delhi Metro also provides key guidelines.

From the experience of DMRC, for such conditions it can be concluded that with open shaft system the piston effects can be sufficient to maintain acceptable conditions inside the tunnel, as long as the ambient DB temperature is below 33^o C. When the outside temperature is higher than 33^o C the tunnel shafts should be closed to prevent any further exchange of air with atmosphere. The station premises (public areas) can be equipped with separate air-conditioning system during the summer and monsoon months to provide acceptable environment for patrons. There shall be provision of Trackway Exhaust System (TES) by which platform air can be re-circulated. The train cars reject substantial heat inside subway. When the trains dwell at the stations TES would capture a large portion of heat

released by the train air conditioners mounted on the roof tops and under gear heat because of braking, before it is mixed with the platform environment.

The train heat generated inside the tunnel sections would be removed by the train piston action. It is envisaged that for the design outside conditions, it may not be necessary to provide forced ventilation using Tunnel Ventilations Fans for normal operating conditions. The two tunnel ventilation shafts would be required at the end of the stations. As the maximum inter station distance in underground stations is 1057.7m therefore considering the ultimate train headway the mid tunnel ventilation shaft would not be required. These end-shafts at the stations also serve as Blast Relief Shafts i.e. the piston pressure is relieved to the atmosphere before the air-blast reaches the station. All these shafts are connected to the tunnels through dampers. The dampers are kept open when the exchange of air with the atmosphere is permitted (Open system). For the closed system the shaft dampers can be in closed mode and the displaced air is dumped in the adjacent tunnel.

Generally each tunnel ventilation shaft has a fan room in which there are two fully reversible tunnel ventilation fans (TVF) are installed with isolation dampers. These dampers are closed when the fan is not in operation. There is a bypass duct around the fan room, which acts as a pressure relief shaft when open during normal conditions, and enables the flow of air to bypass the TV fans, allowing air exchange between tunnels with flows generated by train movements. Dampers are also used to close the connections to tunnels and nozzles when under different operating conditions. The details for the shaft sizes, airflow exchange with the atmosphere, fan capacities can be estimated in more accurate manner with the help of Computer Simulations during the detailed design stage.



Tunnel Ventilation Dampers

8.9 TRACKWAY EXHAUST SYSTEM (TES)

The TES is to be installed in the train ways of each station to directly capture heat rejected by the vehicle propulsion, braking, auxiliary and air conditioning systems as the train dwells in the station. The TES includes both an under platform exhaust (UPE) duct and an Over-trackway (OTE) exhaust duct. The TES uses ducts formed in the under platform void and over the trackway. Exhaust intakes are to be located to coincide with the train-borne heat sources.



Trackway Exhaust Fan

8.10 TUNNEL VENTILATION SYSTEMS (TVS)

The TVS is provided in a Subway system essentially to carry out the following functions:

- (a) Train Pressure relief during normal operation
- (b) Ventilation during maintenance periods, if required
- (c) Removal of smoke during emergency conditions
- (d) Maintenance of smoke free evacuation route and provision of adequate fresh air during fire related emergencies.



Tunnel Ventilation Fan

There are various operating modes (scenarios) for the Tunnel Ventilation system. These are described as under:

8.10.1 Normal Conditions

Normal condition is when the trains are operating to timetable throughout the system, at prescribed headways and dwell times, within given tolerances. The primary source of ventilation during normal conditions is generated by the movement of trains operating within the system and, in some cases, the trackway exhaust system.

During summer and the monsoon seasons, the system will be functioning essentially with the station air conditioning operating. The vent shafts to the surface will enable the tunnel heat to be removed due to train movements. The platform air captured by the trackway exhaust system shall be cooled and recirculated. For less severe (i.e. cool) environmental conditions (or in the event of an AC system failure), station air conditioning will not be used and ventilation shafts will be open to atmosphere (open system) with the trackway exhaust system operating. For cold conditions, the closed system or open system mode may be used, but without any station air conditioning. System heating is achieved by the train heat released into the premises.

8.10.2 Congested Conditions

Congested conditions occur when delays cause disruption to the movement of trains. It is possible that the delays may result in the idling of a train in a tunnel section. Without forced ventilation, excessive tunnel temperatures may result, reduced performance of coach air conditioners that may lead to passenger discomfort.

During congested operations, the tunnel ventilation system is operated to maintain a specific temperature in the vicinity of the car air conditioner condenser coils (i.e. allowing for thermal stratification). The open system congested ventilation shall be via a 'push-pull' effect where tunnel vent fans behind the train are operated in supply and tunnel vent fans ahead of the trains are operated in exhaust mode. Nozzles or booster (jet) fans will be used to direct air into the desired tunnel, if required.

8.10.3 Emergency Conditions

Emergency conditions are when smoke is generated in the tunnel or station trackway. In emergency conditions, the tunnel ventilation system would be set to operate to control the movement of smoke and provide a smoke-free path for evacuation of the passengers and for the fire fighting purposes. The method of controlling the smoke is the same as for the open system congested mode. The ventilation system is operated in a 'push-pull' supply and exhaust mode with jet fans or nozzles driving tunnel flows such that the smoke is forced to move in one direction, enabling evacuation to take place in the opposite direction.

8.11 PRESSURE TRANSIENTS

The movement of trains within the underground system induces unsteady air motion in the tunnels and stations. Together with changes in cross section, this motion of air results in changes in air pressure within trains and for wayside locations. These changes in pressure or 'pressure transients' can be a source of passenger discomfort and can also be harmful to the wayside equipment and structures. Two types of transient phenomenon are generally to be examined:

- a) **Portal Entry and Exit Pressure Transients** – As a train enters a portal, passengers will experience a rise in pressure from when the nose enters until the tail enters. After the tail enters the pressure drops. Similarly, as the nose exits a portal, pressure changes are experienced in the train. There are three locations of the portal between Hil range and Shivaji Nagar Station, ASI and PMC stations PMC and Budhwar Peth station.
- b) **Wayside Pressure Transients** – As trains travel through the system they will pass structures, equipment and patrons on platforms. Equipment would include cross passage doors, lights, dampers, walkways etc. Pressures are positive for the approaching train and negative for retreating trains. Most rapid changes occur with the passage of the train nose and tail. The repetitive nature of these pressures may need to be considered when considering fatigue in the design of equipment.

The detailed analysis to assess the effect of pressure transients will have to be done during the design stage. For the portal entry/exits the effect of higher train speed may pose discomfort to the passengers. Although, based on the recent studies, it is assumed that a design train speed of 85 kmph would not be of major concern. The estimation of Way-side transients during design stage would be necessary to select design mechanical strength of the trackside components and fixtures, e.g. false ceilings, light fittings etc at the platform levels.

8.12 VENTILATION AND AIR CONDITIONING OF ANCILLARY SPACES

Ancillary spaces such as staff room, equipment plantroom, will be mechanically ventilated or air conditioned in accordance with the desired air change rates and temperatures/humidity.

All ancillary areas that require 24-hour air conditioning will be provided with fan-coil units (FCU) and standby AC units. During the revenue hours when the main chilled water system is running the FCU will be used for air-conditioning and in non-revenue hours standby AC units will be operated. Return air grilles will be fitted with washable air filters for the recirculation of the air.

Where fresh air is required it will be supplied to the indoor unit via a fresh air supply system, complete with filter, common to a group of ancillary areas. The fresh air unit will be located in the VAC plant room and will be time switch controlled with local override. Temperature control will include an alarm setting, which is activated on attaining high temperature.

8.13 STATION SMOKE MANAGEMENT SYSTEM

The Trackway Exhaust and Concourse smoke extract fans will be provided for smoke extract purposes from the public areas and will operate in various modes depending on the location of the fire. The associated supply air-handling units will provide support, to assist in smoke control in the event of a fire in the station. The control of this system in fire mode will be fail-safe. These exhaust fans will be provided with “essential” power supplies, with automatic changeover on loss of supply.

Down stand beams will be provided underneath the ceiling around floor openings for stairs and escalators, so that a smoke reservoir is formed on the ceiling. The smoke will be contained in this reservoir at ceiling level and exhausted to atmosphere. By controlling smoke in this manner, it is possible to maintain a relatively smoke clear layer above human head height and to protect the escape route, giving sufficient time for evacuation. The stations will be designed to accommodate the full smoke exhaust volumes and thus prevent the reservoir from completely filling with smoke. To provide an additional barrier against smoke migration, the overall smoke management system would be designed to provide a

draught of fresh air through entrances and escape routes, to assist in protecting those routes from smoke.

8.13.1 System Components for VAC

The various components and equipment used in the VAC system are described in the following sections:

8.13.2 Station Air Conditioning

The platform and concourse areas will be air-conditioned using supply 'air handling units' located in Environmental Control plant rooms throughout the station. Each platform will be served by at least two separate air handling units (AHU's) with the distribution systems combined along each platform to ensure coverage of all areas in the event of single equipment failure. Based on the initial estimation about 6 units (2 for the concourse each with 18 cum/s and 4 for the platform each having 24 cum/s air-flow) would be needed for the full system capacity.



Concourse Air Handling Unit

These air conditioning systems mix return air with a desired quantity of outside air. The outside air requirement is based on occupancy, with a minimum of 5 liters per second per person or 10% of circulated air volume, whichever is the greater. The provision of free cooling by a simple two-position economizer control system will be included, with the use of enthalpy sensors to determine the benefits of using return air or outside air. This will signal

the control system to operate dampers between minimum and full fresh air, so as to minimize the enthalpy reduction needed to be achieved by the cooling coil. This mixture of outside and return air is then filtered by means of suitable filters and then cooled by a cooling coil before being distributed as supply air via high level insulated ductwork to diffusers, discharging the air into the serviced space in a controlled way to minimize draughts. Return air to the platform areas is extracted via the trackway exhaust system and either returned to the AHU'S or exhausted as required.

Water-cooled chiller units with screw compressors are recommended to be provided at each station, which are energy efficient. These units can be installed in a chiller plant room at surface level or in the underground premises. Based on the initial concept design, the estimated capacity for a typical station would be around 660 TR, hence three units of 330TR (including one stand-by) may be required for full system capacity (i.e. design PHPDT traffic requirement). During the detail design stage this estimated capacity might get marginally changed for individual station depending on the heat loads and geometry of the stations. It is recommended that initially 2X330 TR may be installed with the provision in terms of space be kept for the future/stand by addition.

During the detail design stage this estimated capacity might get marginally changed for individual station depending on the heat loads.



Platform Air Handling Unit

In view of the temperate outdoor conditions, alternatively, it is possible to utilize air-cooled chiller units, which can save large amount of water requirement. The air-cooled chillers should be equipped with screw compressors so that they can be operated at a very less load with high efficiency. These units also eliminate requirement of condenser water circuits including pumps, cooling towers and make up water plants, but are less efficient as compared to the water-cooled- units.

8.13.3 Tunnel Ventilation System

As described earlier tunnel ventilation fans will be installed in each of the fan rooms near vent shafts. There shall be two fans in a fan room at each end of the station. The fan capacity depends on the inter-station distances and may vary from 60 m³/s to 100 m³/s. The exact capacity will be obtained through the simulation during detailed stage. If necessary, nozzle type structures made up of concrete or steel may also be constructed to achieve desired airflow and air velocity in the tunnel sections. Alternatively booster fans (jet fans) may be installed to direct the flow in the desired direction. These fans may also be used for emergency ventilation at crossover locations.

The distance between Range Hill and Shivaji Nagar Station is 1604.6 meter and the ramp portion length is 360 m therefore, Tunnel Booster Fans (TBF) may be required in the ramp portion. The capacity of the TBFs can be obtained from the simulations.

The trackway exhaust system will have two fans of each 30 cum/sec. for each platform. The connections to tunnels and shafts will be through damper units that may be either electrically or pneumatic actuated.

A comprehensive remote control and monitoring system for operation and control of tunnel ventilation system will be installed. The alarm and status signals from the equipment will be transmitted to operations control centers (OCC) through SCADA. The activation command for a group of equipment will be initiated from OCC by the controller. There shall be a mode table defining sequence of equipment operation for each event or scenario.

8.13.4 Space Requirement for VAC System

The station air conditioning and tunnel ventilation equipment plant room are normally located at each end of the concourse for the two level stations. The approximate area for air handling equipment room would be 400 sq. m and for tunnel ventilation fan room would be 600 sq. m. respectively at each end of the station. The tunnel vent shafts of approximately 20 sq. m. area will be constructed at each end of the stations. There shall be supply shaft and exhaust shafts at the stations of similar dimensions. For the underground stations with large inter station distances there may be necessity of constructing mid tunnel shaft. Considering the ultimate headway of 3-minute and the inter-station distances in Pune metro corridor the mid tunnel ventilation shafts are not required.

However, the adjacent station's end shafts will have fans with higher pressure since thrust required will be more. We can reduce the pressure (and also fan power requirement) if booster fans are used but this is preferred if cut-cover tunnel sections is there. Computer simulation during design stage would tell about the need of mid tunnel cooling dumping. Although increase in in-bound dumping can eliminate this need. Train AC condensers should work at full load till 50°C.

8.14 CONTROL AND MONITORING FACILITIES

For the underground stations the control and monitoring of station services and systems such as station air-conditioning, ventilation to plant rooms, lighting, pumping systems, lifts & Escalators, etc shall be performed at Station Control Room (SCR). However, the operation and control of Tunnel Ventilation as well as Smoke Management system will normally be done through OCC. All these systems shall be equipped with automatic, manual, local and remote operation modes. The alarms and signals from the equipment at stations shall be transmitted to the OCC via communication network (such as FOTS).

There shall be an Auxiliary Power Controller at OCC who will be monitoring these services and systems. The command signals will be initiated at OCC and relayed upto the relevant equipment for operation. The feedback signal is received through SCADA whether the command is implemented or not. The control from OCC is generally performed using 'Mode Tables' for each system. This table defines the sequence of the desired equipment that need to be operated based on the event. The abnormal conditions such as train congestion, emergency, fire in subway would be detected by various components and the emergency response thereto will be activated based on the mode tables. In the event that remote control is not possible due to any reason, the local control via SCR would be performed. The OCC will also be used for logging the alarm status, fault occurrences, and other maintenance related data for the above systems.

8.15 CODES AND STANDARDS

The concept VAC design is guided by the following codes and standards:

- a) SEDH – Subway Environment Design Handbook
- b) ASHRAE – Handbook, current series.
- c) CIBSE – relevant document
- d) NFPA – 130, 2003 edition

Chapter - 9

Maintenance Depot



- 9.1 Introduction
- 9.2 Estimation of km Earning Per Day Per Rake
- 9.3 Rolling Stock Maintenance Needs
- 9.4 Year Wise Planning of Maintenance Facilities
- 9.5 Design of Depot Facilities
- 9.6 Operational Features
- 9.7 Safety Features in Design of Maintenance Depot



CHAPTER - 9

MAINTENANCE DEPOT

9.1 INTRODUCTION

Depot-cum-workshops for Corridor 1 and for Corridor 2 will be used for stabling of trains, cleaning, schedule inspections, wheel-re-profiling, minor & major repairs as well as Overhauls. Trains operational on the two corridors shall have stabling facilities at terminal station also.

Corridor 1 – From Pimpri Chinchwad to Swargate

Corridor 2 – From Vanaz to Ramvadi.

In broad terms the chapter covers conceptual design on following aspects and will work as a guide line later:

- Layout of stabling shed, inspection shed, heavy repair, minor repairs, maintenance workshop and cleaning of Rolling Stock.
- Operational and functional safety requirements.
- Ancillary buildings for other maintenance facilities.
- Electric & mechanical Services, power supply and distribution system.
- Water supply, Drainage & Sewerage.

9.2 ESTIMATION OF KM EARNING/DAY/RAKE

Year	Corridor 1	Corridor 2
2018	461 km	372 km
2021	461 km	385 km
2031	469 km	395 km

9.3 ROLLING STOCK MAINTENANCE NEEDS

9.3.1 Maintenance Schedule

The following maintenance schedule has been envisaged for conceptual design of depot assuming 480 km and 400 km of running per train per day for, Corridor 1 & 2 respectively, taking in consideration the passenger load of 2018, 2021 and 2031 respectively.

Type of Schedule	Interval	Work Content	Locations
Daily	Daily	Check on the train condition and function at every daily service completion. Interval cleaning/mopping of floor and walls with vacuum cleaner.	Stabling Lines
“A” Service Check	At 5000 Km 10 days for corridor 1 12days for corridor 2	Detailed inspection and testing of sub-systems, under frame, replacement/topping up of oils & lubricants.	Inspection Bays
“B” Service Check	15,000 Km 30 days for corridor 1 36 days for corridor 2	Detailed Inspection of ‘A’ type tasks plus items at multiples of 15,000 Km (‘B’ type tasks)	Inspection Bays
Intermediate Overhaul (IOH)	420,000 Km 3 years for corridor 1 3.5 years for corridor 2	Check and testing of all sub-assemblies (Electrical + Mechanical). Overhaul of pneumatic valves, Compressor. Condition based maintenance of sub-systems to bring them to original condition. Replacement of parts and rectification, trial run.	Workshop
Periodical Overhaul	840,000 Km (6-7 Years)	Dismantling of all sub-assemblies, bogies suspension system, traction motor, gear,	Workshop

(POH)		control equipment, air-conditioning units etc. Overhauling to bring them to original condition. Checking repair and replacement as necessary. Inspection and trial.	
Heavy Repairs	-	Changing of heavy item such as bogies, traction motor, axles, gear cases & axle boxes etc.	Workshop

9.3.2 Washing Needs of Rolling Stock

Cleanliness of the trains is essential. Following schedules are recommended for environment of Pune :

Kind of Inspection	Maintenance Cycle	Time	Maintenance Place
Outside cleaning (wet washing on automatic washing plant)	2 Days	5-8 mins	Single Pass through Automatic washing plant of Depot
Outside heavy Cleaning (wet washing on automatic washing plant and Front Face, Vestibule/Buffer area. Floor, walls inside/outside of cars and roof. Manually)	20 days	1.5-2hrs.	(Automatic washing plant & cleaning & washing shed)

9.4 EARWISE PLANNING OF MAINTENANCE FACILITY

Corridor - I :PCMC – SWARGATE

Year	Headway	No. of Rakes	No. of Coaches
2018	4 minutes	19	76
2021	3.5 minutes	22	88
2031	3.5 minutes	22	88

Corridor - II :VANAZ – RAMVADI

Year	Headway	No. of Rakes	No. of Coaches
2018	12 minutes	7	28
2021	8minutes	10	40
2031	63.5 minutes	12	48

9.4.1 Requirement of Maintenance/Inspection Lines (Corridor-I)

Schedule	Maintenance Requirement (No. of cars)	Lines Needed
Upto the year 2031 (Maximum no. of rake holding is 22 x 4 cars)		
'A' Checks (5000 kms) or 10 days	22 x 4 = 88 cars	2 Line x 6* cars (with sunken floor)
'B' Checks (15000 kms) or 30 days	22 x 4 = 88 cars	1 Line x 6* cars (with sunken floor). 'B' checks can be collectively performed along with 'A' schedule on same line, but this line has to be provided for future work load of 'B' checks.
Unscheduled line & adjustment line	For minor repairs, testing and after IOH/POH adjustments	1 line x 6* cars (sunken floor)
Total Requirement (Corridor I)		4 lines with sunken floor i.e. with 2 bays of 2 lines each

*6- Car lines are envisaged with a view of reformation of 4 car trains to 6 car formation in future.

9.4.2 Requirement of Stabling Lines for Corridor-I :-

Year	Stabling Lines at Terminals	Stabling in Baddowal Depot	
		On Inspection Line	On Stabling Lines
Upto 2018	2 Line x 6* Car(one on each side)	4 Line x 6* Car	16 Line x 6* Car
Upto 2021	2 Line x 6* Car(one on each side)	4 Line x 6* Car	16 Line x 6* Car
Upto 2031	4 Line x 6* Car(one on each side)	4 Line x 6* Car	17 Line x 6* Car

*6- Car lines are envisaged with a view of reformation of 4 car trains to 6 car formation in future.

9.4.3 Requirement of Workshop Lines for IOH/POH & Heavy Repairs of cars for corridor-I and POH/IOH of Heavy Equipment of cars for corridor-II:-

Year	No. of Lines (One Bay)	Total No. of Lines	Remarks
2018	4	4	POH of heavy equipments such as mechanical component, couplers, air-conditioners, bogies, Traction Motor, Vehicle Doors and Window and brake modules shall be done at Hill Range Station.
2021	4	4	
2031	4	4	

Note: The above requirement is based on

- The total annual average collective IOH/POH load of both the corridors range from 128 cars to 180 cars between Year 2018-2031. The average monthly intake in workshop for IOH/POH ranges from 11 to 16 cars. Taking average IOH/ POH time of 15 days per train of 4 coaches minimum of two workshop lines is required.
- In addition two more workshop lines for (a) unscheduled lifting and bogie changing and for storage of wheels, bogie and axles are essential.

9.4.4 Requirement of Maintenance/Inspection Lines – Corridor-II :-

Schedule	Maintenance Requirement (No. of Cars)	Lines Needed
Upto the year 2021 (Maximum no. of rake holding is 10 x 4 cars)		
'A' Checks (5000 kms) or 12 days	10 x 4 cars = 48 cars	1 Line x 6* cars (with sunken floor)
'B' Checks (15000 kms) or 36 days	10 x 4 cars = 40 cars	1 Line x 6* cars (with sunken floor). 'B' checks can be collectively performed along with unscheduled and adjustment requirements of car
From the year 2021-2031 (Maximum no. of rake holding is 12 x 4 cars)		
'A' Checks	12 x 4 = 48 cars	Same as indicated for the year 2021 above. one new line is required.
'B' Checks	12 x 4 = 48 cars	

Schedule	Maintenance Requirement (No. of Cars)	Lines Needed
Total Requirement (Corridor-II)		3 lines with sunken floor i.e. one bay of 3 lines

*6- Car lines are envisaged with a view of reformation of 4 car trains to 6 car formation in future.

9.4.5 Requirement of Stabling Lines for Corridor-II :-

Year	Stabling Lines at Rohan Road Terminal	Stabling in Gill Village Depot	
		On inspection line	On Stabling Lines
Upto 2018	2x1 line x 6* Car	2 Line	6 Line x 6 Car*
Upto 2021	2x1 line x 6* Car	2 Line	8 Line x 6 Car*
Upto 2031	2x 1 line x 6* Car	3 Line	15 Line x 6* Car

*6- Car lines are envisaged with a view of reformation of 4 car trains to 6 car formation in future.

9.4.6 Requirement of Workshop Lines for Heavy Repairs :-

Year	No. of Lines (One Bay)	Total No. of Lines	Remarks
2018	2	2	POH/IOH of heavy equipments such as mechanical components, couplers air-conditioners, brake modules, bogies, traction motor, vehicle door and window of this Corridor shall be carried out at Hill Range Station. The disassembly before POH/IOH, assembly and testing after IOH and POH/IOH of remaining of the equipments shall be carried out by the workshop itself.
2021	2	2	
2031	2	2	

Following facilities shall be provided to include the ability to carry out the inspection, of the following sub-systems/equipments:

- Electronics; PA/PIS
- Mechanical components, couplers etc;
- Batteries;
- Air conditioner;
- Brake modules;
- Bogie;
- Traction Motor
- Vehicle doors, windows and internal fittings.
- Power System including converter, ckt breaker etc.

These activities shall be grouped into “A” checks and “B” Checks. The minor scheduled inspections (“A” checks) shall be carried out during the day off peak and night. Since “B” checks take longer time, these cannot be completed in the off peak times. Certain inspection lines will be nominated for “A” checks. For “B” Checks, separate line will be nominated where the rakes may be kept for long time.

9.5 DESIGN OF DEPOT FACILITIES (Corridor-I and Corridor-II)

As per advised dimensions of the Rolling Stock, the length of 6-Car train would be 128.94m (say 130m). In the design of the Inspection shed and stabling lines, length of 6-car train is taken in consideration.

9.5.1 Stabling Lines

Lengths of 6 - car rake = 128.94 meters (say 130 m).

Minimum length of each stabling lines is computed as below:

Length = 130m (rake length) + 15m (for cross pathway, signal and friction buffers) = 145 m.

Stabling lines are designed for 145 m lengths to cater for safe gap from the friction buffer stops and the signaling interlocking needs.

Looking to the car width of 2900 on SG, 5.0m “Track Centre” is proposed for all the stabling lines. Thus, space between stabling shall be sufficient to include 800mm wide pathway to be constructed between tracks to provide access for internal train cleaning.

9.5.2 Inspection Shed

The length of Inspection shed is computed as below.

Length = [Cross path at end + space for friction buffer stop + Length of Rake + Cross path at end which keeps Gap from gate]

Length = 5.0m + 145m + 5.0m = 155m (say 160m)

If column space is taken as 10m for steel columns, shed length of 160m including two expansion joints (1m each) is proposed. This will have the composite building with workshop.

There shall be two inspection bays of 160 x 15 m size each with two inspection lines having sunken floor with overhead roof inspection platforms. The floor will be sunken by 1100mm. The center line of the tracks will be 7500mm apart. The centerline of nearest inspection line adjacent to columns of inspection shed would be at a distance of 3750 mm. The two bays of 160 x 15 m covering two lines each are planned for entire inspection load of 22 to 25 train sets for corridors -1. Similarly, 3 line one inspection bay of 160 x 21.5 m size is envisaged for corridor 2 with 2 lines initially and provision of one more sunken line during 2021-2031.

Roof Inspection platforms supported on the columns shall be provided. There would be lighting below the rail level to facilitate the under frame inspection. Ramps of 1:8 slopes, 3 meter wide have been provided with sunken floor system for movement of material for the cars. Further, 5m cross pathways are left at each end for movement of material by fork lifter/Leister/Hand trolley. 415V 3 phase 50 Hz, 230V 1 phase 50 Hz AC supply and Pneumatic supply shall also be made available on each inspection shed columns. Air-circulators shall be provided on each column. The inspection bay shall be provided with O/H crane of 1.5 T to facilitate lifting of equipment.

9.5.3 Workshop Shed (Corridor 1)

There shall be two bays comprising of four lines. Size of each workshop bay is proposed to be 160m x 21m. The unscheduled lifting and heavy repair line shall be fitted with jack system capable to lift the 6-car unit simultaneously for quick change of bogie, thereby saving down time of Rolling Stock.

There shall be two bays comprising of four lines. Size of each workshop bay is proposed to be 160m x 21m. The unscheduled lifting and heavy repair line shall be fitted with jack system capable to lift the 6-car unit simultaneously for quick change of bogie, thereby saving down time of Rolling Stock.

The IInd and IIIrd workshop line shall be earmarked for POH/IOH of coaches of Corridor - I and POH/IOH of equipment of Corridor - II. These lines are to be provided with pits at regular intervals for inspection of undercarriage with turn tables at the end. The IVth workshop line shall be used for storage of the bogies and wheels. Facility of Pits for bogie-body connection and disconnection shall be made on this line.

9.5.4 Workshop Shed (Corridor-II)

Workshop shall be of 160 x 21 meters size with two workshop lines only. Line one shall be utilized for lifting and lowering and change of bogies/heavy repairs. This Line shall be provided with lifting jacks upto 75 meters and rest of its length shall be utilized for IOH/POH of the equipment other than those shown in remarks column of Para 1.4.4. The other line shall be utilized for storage of wheels/bogies upto a length of 75 meters and the rest of it can be used for connection/disconnection of coaches, inspection of bogies/wheels and their assembly and hence should be provided 8 meters long pits to facilitate such activities.

There shall be washing and cleaning equipments on the workshop floor. Bogie test stand shall be provided on the nominated bay. Other heavy machinery shall also be suitably installed on the workshop floor. Air-circulators, lights and convenience powers supply points, compressed air supply line shall be provided on each workshop column.

All the workshop lines shall be inter linked through turn table. Cross track equipped with turntables shall be provided for movement between bays. The capacity of O/H crane shall be optimized by using this concept, resulting in savings in structure cost. Repair of heavy equipments such as air conditioner shall be located so that it does not affect the movement inside workshop.

The small component and bogie painting and battery maintenance will be located in both the workshop with arrangement that fumes are extracted by suitable exhaust systems.

Workshop Corridor-1 will have service building with array of rooms along its length. Total size is proposed to be 160 x 8m. However, lesser number of rooms may be planned at Corridor – II workshop. These can be made by column and beam structure and architecture made of brick works. These shall cater for overhaul sections, offices, costly item store, locker rooms, toilets etc. The rooms shall be so located that both longitudinal sides of the shed remain open for through ventilation. The sidewall shall have sufficient width of louvers for providing adequate ventilation.

Following equipment; repair/overhaul facilities are planned in the workshop at Hill Range Station:

Corridor - 1

1. Body furnishing
2. Bogie
3. Wheels
4. Traction Motors
5. Axle Box and axle Bearing
6. Power Collector
7. Transformer, converter/inverter, circuit breaker

Corridor - 2

1. Bogie
2. Wheels
3. Traction Motors
4. Axle Box and axle bearing
5. Transformer, C/I, Circuit Breaker
6. Air-conditioner
7. Brake Equipment
8. Door actuators

8. Battery
9. Air Compressor
10. Air-conditioner
11. Brake Equipment
12. Door actuators
13. Control and measuring equipments
14. Pneumatic equipment

9.5.5 Coach Unloading Line

As the coaches are on standard gauge, these shall reach the depot by the road on trailers. To unload the coaches and bring them to the track, the shunting neck shall be designed as unloading line as well. It shall have the insulated track embedded in the floor facilitating the movement of road trawler, which brings in the cars, on it. The length of the track embedded area shall be 50 m long.

9.6 OPERATIONAL FEATURES

The rake induction and withdrawal to main line will be primarily from the stabling shed. Further, provisions are there for direct rake induction and withdrawal to main line from Inspection Shed/workshop area. Movement from depot to the main line is so planned that the headway of main line is not affected. Simultaneous receipt and dispatch of trains from depot to main line is feasible in the present site scenario. Both of these activities will be done effectively without effecting the train operation on the main line. The stabling lines would be interlocked with the main line thereby induction of train from the stabling would be safe and without loss of time. The proposition for a transfer track on the incoming line as well as on the outgoing line to facilitate the movement of rake in the depot by Operation Control Centre (OCC) even though the further path inside the depot is not clear shall be explored in the detailed design stage depending on the actual availability of land.

An emergency line is provided from which an emergency rescue vehicle may be dispatched to main line in the event of emergency if necessary.

9.6.1 Infrastructure Facilities

I. Inspection Shed

II. Stabling Lines in Depots

The requirement of lines shall be in accordance with the tables indicated at 1.4.2& 1.4.3 (i).

III. Automatic Coach Washing Plant

Provision is made for rolling Stock exterior surfaces to be washed using a fully automated Train Washing System, with a throughput capacity of approximately six trains per hour. This shall be accommodated in the 130m x 10m area. Trains can move to the stabling shed directly from Automatic wash Plant.

IV. Test Track

A test track of 1000m in length covered & fenced is provided beside workshop in the depot. It shall be equipped with signaling equipments (ATP/ATO). It shall be used for the commissioning of the new trains, their trials and testing of the trains after the IOH and POH.

V. Heavy Cleaning Shed

Monthly heavy cleaning of interior walls, floors, seats, windows glasses etc, outside heavy cleaning, Front/rear Face, Vestibule/ Buffer area, outside walls and roof shall be done manually in the interior cleaning plant designed for cleaning of one four car train at a time.

VI. Power Supply

Auxiliary substations are planned for catering to the power supply requirement of the whole depot and workshop. Details of connected load feeder shall be worked out. Taking diversity factor of 0.5 the maximum demands shall be computed. Two Auxiliary substations are proposed, as the demand by machines in Workshop area would be very large. The standby power supply is proposed through DG set with AMF panel. The capacity of DG set will be adequate to supply all essential loads without over loading.

VII. Compressed Air Supply

Silent type compressor units shall be suitably installed inside the workshops at convenient location for the supply of compressed air to workshop and Inspection shed. Thus, the pneumatic pipeline shall run within the shed.

VIII. Water Supply, Sewerage and Drainage Works

In house facilities shall be developed for the water supply of the entire depot cum workshop. Sewerage, storm water drainage shall be given due care while designing the depot for efficient system functioning. Past records of Municipal Corporation shall be used to design the drainage system. Rainwater harvesting would be given due emphases to charge the underground reserves.

IX. Ancillary Workshop

This workshop will have a line both at floor level with provision of pits. Arrangement for repairs of Shunters, Rail Road Vehicles and other ancillary vehicles will be provided. These vehicles will also be housed here itself. Heavy lifting works can be carried out in main workshop.

Ancillary workshop will be used for storing OHE/rigid OHE parts and their maintenance/repair for restoration of 25kV feed system.

X. Watch Towers

There shall be provision of adequate number of watchtowers for the vigilance of depot boundary.

XI. Administrative Building

An administrative building close to the main entrance is planned. It can be suitably sized and architecturally designed at the detailed design stage. A time and security office is also provided close to main entrance. It shall be equipped with suitable Access control system for all the staff working in the complex.

Ample parking shall be provided for the two wheelers and four wheelers close to the depot entry.

XII. Shed and Buildings

The shed and buildings normally provided in the depot with their sizes and brief functions are indicated in **Annexure-I**. Some of these buildings are not depicted on the layout drawing. At the detailed design stage depending upon the land availability, the decision to locate these buildings can be taken. These can then be architecturally and functionally grouped.

XIII. Plant and Machinery

Requirement of major plants and machinery, which are vital for operational needs, is given in **Annexure-II**.

9.7 FOLLOWING SAFETY FEATURES SHOULD BE INCORPORATED IN THE DESIGN OF THE MAINTENANCE DEPOTS.

- a) 1.5 EOT cranes in the inspection bay should be interlocked with OHE in such a way that the cranes become operational only when OHE is isolated and grounded.

- b)** Red flasher lights should be installed along the inspection lines at conspicuous location to indicate the OHE is 'Live'.
- c)** Multi level wheel and TM stacking arrangement should be a inbuilt feature at the end of Workshop Lines.
- d)** Pillers in the inspection bay & workshop should have provision for power sockets.
- e)** Placement of rakes from inspection/workshop lines on to washing lines for interior cleaning on their own power should be possible. Linking of OHE and its isolation at the cleaning area should be provided. Necessary requirements of safety should be kept in view.
- f)** The roof inspection platform should have at least two openable doors to facilitate staff to go up the roof for cleaning of roof. Suitable safety interlock should be provided to ensure maintenance staff are enabled to climb on the roof inspection platform only after the OHE is isolated.
- g)** Control Centre, PPIO & store depot must be close to Workshop.
- h)** Width of the doors of the sections wherein repairs of equipments are done should be atleast 2 meters wide to allow free passage of equipment through them.
- i)** Provision of water hydrants should be done in workshops stabling yards also.
- j)** Compressed air points along with water taps should be available in interior of buildings for cleaning.

Annexure-I
**List of Buildings
Depot – cum – Workshop (Corridor – I)**

S.No	Name of Building	Size	Brief Function
1	Inspection Shed	160 x 30	Servicing of Cars for 10 days & 30 days inspection.
	Workshop Shed	160 x 42	Major repair & overhaul of rolling stocks, diesel shunters, electric tractors, tower wagons. All heavy lifting hobs.
	Associated Sections	160 x 8m	Rooms for carrying out the inspection & workshop activity.
2.	Stores Depot & Offices including Goods Platform with Ramp	42.5 x 42.5m	<ul style="list-style-type: none"> i. Stocking of spares for regular & emergency requirement including consumable items. ii. This store caters for the requirement of depot for rolling stock & other disciplines. iii. To be provided with computerized inventory control. iv. Loading/Unloading of material received by road.
3.	Elect. Substation DG set room	30 x 20m	To cater for normal and emergency power supply for depot, workshop, service and all other ancillary buildings, essential power supply for essential loads and security light.
4.	Track Feed Traction repair depot & E & M repair shop	80 x 30m (partly double storey)	<p>Stabling and routine maintenance of shunting engine etc. & Traction maintenance depot.</p> <p>For maintenance of lifts/escalators and other General service works.</p>
5.	Cycle & Scooter Stand	25 x 6m	To park cycles and Scooter
6.	Auto Coach washing plant and washing apron	160 x 10m	For automatic washing of coaches. Washing apron is for collection of dripping water and its proper drainage.
7.	Interior Cleaning Plant	160 x 6.5m	Heavy wet washing of rakes from inside, under frame, roof at 30 days interval.
8.	P. way office, store & Workshop including Welding plant	80 x 20m	<ul style="list-style-type: none"> i. For track maintenance of section and depot. ii. To weld rails for construction period only. iii. To stable track Tamping machine.
9.	Security office & Time	15 x 8m	For security personnel.

S.No	Name of Building	Size	Brief Function
	Office Garages (4 Nos.)		For time punching For parking vehicle jeep, truck etc.
10.	Check Post (2 Nos.)	5 x 3m	For security check of incoming/outgoing staff material and coaches.
11.	Watch Tower (3nos)	3.5 x 2.5m	For security of the depot especially during nighttime.
12.	Depot control centre & Crew booking centre	25x20m (double storey)	To control movement of trains in and out of the depot & out of the depot & for crew booking.
13.	O.H raw water Tank	1,00,000Ltrs Capacity	Storage of water, capacity 1,00,000 sLtrs each.
14.	Pump house Bore well	7.3 x 5.4 200 mm	Submersible type pump planned with 200 mm diameter bore well.
15.	Repair shops for S & T	40 x 20m	For the AFC gates, Signaling and telecom equipment.
16.	Work shop Manager Office	30 x 20m	Office of Depot in charge
17.	ATP & ATO Room	4 x 5m	To keep equipments of ATP/ATO
18.	Waste Water Treatment Plant	12 x 6m	For treating the discharge waters of the depot and remove the oil, acids etc. before discharging into the river, with U/G tank.
19.	Canteen	200 sqm	To cater staff of depot and workshop. Obligatory as per statutory requirements.
20.	Testing Line with ATP/ATO	1000m	Testing after heavy repairs, IOH & POH and for new train formations.

Note

- Depending on the administrative decision, the location of the building shall be suitably at the detailed design stage incorporating the site topography, architectural nitty gritty and minor adjustment in sizes looking to the available land.
- Some of the buildings like stabling shed; security office etc shall be pre-engineered structure. The decision in this regard may be taken at the detailed design stage.

Annexure-II

**List of Plants& Equipment
Depot - cum - Workshop (Corridor - II)**

S.No.	Equipment	Qty	Unit	Imp/Ind
1.	Under floor Pit wheel lathe, Chip crusher and conveyor for lathe on pit, Electric tractor for movement over under floor wheel lathe	1	Nos	Imp
2.	Under floor lifting system for 2 car unit for replacement of bogie	2	Set	Imp
3.	Mobile jacks 15T for lifting cars	24+12	Nos	Imp
4.	Re-railing equipment consisting of rail cum road vehicle and associated jack system etc.	1	Set	Imp
5.	Run through type Automatic Washing plant for Metro cars.	1	Nos	Imp
6.	Rail fed Bogie wash plant	1	Nos	Imp
7.	Bogie test stand	1	Nos	Imp
8.	Work lift platform	6	Nos	Imp
9.	Electric bogie tractor for pulling cars and bogies inside workshop	2	Nos	Imp
10.	Chemical cleaning tanks, ultrasonic cleaning tanks, etc	1	Set	Imp
11.	Compressor for Inspection shed & shop air supply	2	Nos	Ind
12.	Travelling O/H crane Workshop 10T- 4 nos; 5T- 4 nos (with auxiliary capacity of 5T)	8	Nos	Ind
13.	Mobile jib crane	4	Nos	Ind
14.	Mobile lifting table	6	Nos	Ind
15.	Car body stands	36+12	Nos	Ind
16.	Bogie turn tables	3	Nos	Ind
17.	Under frame & Bogie blowing plant	1		Ind
18.	AC filter cleaning machine	1	Nos	Ind
19.	Portable cleaning plant for rolling stock	1	Nos	Ind
20.	High-pressure washing pump for front and rear end cleaning of car	2	Nos	Ind

S.No.	Equipment	Qty	Unit	Imp/Ind
21.	Shot blast cleaner	1	Set	Ind
22.	Paint booth for small parts	1	Set	Ind
23.	Axle shaft inspection station	1	Set	Ind
24.	Industrial furniture	1	L.s.	Ind
25.	Minor equipment and collective tools	-	Set	Ind
26.	Induction heater	1	No.	Ind
27.	Oven for the motors	1	No.	Ind
28.	EMU battery charger	2+1*	Nos.	Ind
29.	Welding equipments (Mobile welding, oxyacetelene, fixed arc welding)	1	Set	Ind
30.	Electric and pneumatic tools	-	Set	Ind
31.	Measuring and testing equipment	-	Set	Ind
32.	Tool kits	-	Nos.	Ind
33.	Mobile safety steps	15+5	Nos.	Ind
34.	Fork lift tractor	2	Nos.	Ind
35.	Pallet trucks	6	Nos.	Ind
36.	Diesel/battery Shunting Locomotive	1	Nos.	Ind
37.	Road vehicles (pickup van/ truck)	2	Set	Ind
38.	Miscellaneous office equipments	-	Nos.	Ind
39.	Vertical Boring machine for wheel discs	1	No.	Ind
40.	Press for removal and pressing of the wheels on axles	1	No.	Ind
41.	Surface wheel lathe	1	No.	Ind
42.	Axle journal turning and burnishing lathe	1	No.	Ind
43.	Special jigs and fixtures and test benches for Rolling stock			Ind

*Additional requirement in the event of reformation of 4 car trains to 6 car trains.

Annexure-III

**List of Buildings
Depot - cum- Workshop (Corridor - II)**

S.No	Name of Building	Size	Brief Function
1	Inspection Shed	160 x 15	Servicing of Cars for 15 days & 45 days inspection.
	Workshop Shed	160 x 21	Major repair & overhaul of rolling stocks, diesel shunters, electric tractors, tower wagons. All heavy lifting hobs.
	Associated Sections	80 x 8m	Rooms for carrying out the inspection & workshop activity.
2.	Stores Depot & Offices including Goods Platform with Ramp	42.5 x 42.5m	v. Stocking of spares for regular & emergency requirement including consumable items. vi. This store caters for the requirement of depot for rolling stock & other disciplines. vii. To be provided with computerized inventory control. viii. Loading/Unloading of material received by road.
3.	Elect. Substation DG set room	20 x 20m	To cater for normal and emergency power supply for depot, workshop, service and all other ancillary buildings, essential power supply for essential loads and security light.
4.	Track Feed Traction repair depot & E & M repair shop	80 x 30m (partly double storey)	Stabling and routine maintenance of shunting engine etc. & Traction maintenance depot. For maintenance of lifts/escalators and other General service works.
5.	Cycle & Scooter Stand	25 x 6m	To park cycles and Scooter
6.	Auto Coach washing plant and washing apron	160 x 10m	For automatic washing of coaches. Washing apron is for collection of dripping water and its proper drainage.
7.	Interior Cleaning Plant	160 x 6.5m	Heavy wet washing of rakes from inside, under frame, roof at 30 days interval.
8.	P.way office, store & Workshop including Welding plant	80 x 20m	iv. For track maintenance of section and depot. v. To weld rails for construction period only. vi. To stable track Tamping machine.
9.	Security office	15 x 8m	For security personnel.

S.No	Name of Building	Size	Brief Function
	&Time Office Garages (4 Nos.)		For time punching For parking vehicle jeep, truck etc.
10.	Check Post (2 Nos.)	5 x 3m	For security check of incoming/outgoing staff material and coaches.
11.	Watch Tower (3nos)	3.5 x 2.5m	For security of the depot especially during nighttime.
12.	Depot control centre & Crew booking centre	25x20m (double storey)	To control movement of trains in and out of the depot & out of the depot & for crew booking.
13.	O.H raw water Tank	1,00,000Ltrs Capacity	Storage of water, capacity 1,00,000Ltrs each.
14.	Pump house Bore well	7.3 x 5.4 200 mm	Submersible type pump planned with 200 mm diameter bore well.
15.	Repair shops for S & T	40 x 20m	For the AFC gates, Signaling and telecom equipment.
16.	Work shop Manager Office	30 x 20m	Office of Depot in charge
17.	ATP & ATO Room	4 x 5m	To keep equipments of ATP/ATO
18.	Waste Water Treatment Plant	12 x 6m	For treating the discharge waters of the depot and remove the oil, acids etc. before discharging into the river, with U/G tank.
19.	Canteen	100 sqm	To cater staff of depot and workshop. Obligatory as per statutory requirements.
20.	Testing Line with ATP/ATO	1000m	Testing after heavy repairs, IOH & POH and for new train formations.

Note

- Depending on the administrative decision, the location of the building shall be suitably at the detailed design stage incorporating the site topography, architectural nitty gritty and minor adjustment in sizes looking to the available land.
- Some of the buildings like stabling shed; security office etc shall be pre-engineered structure. The decision in this regard may be taken at the detailed design stage.

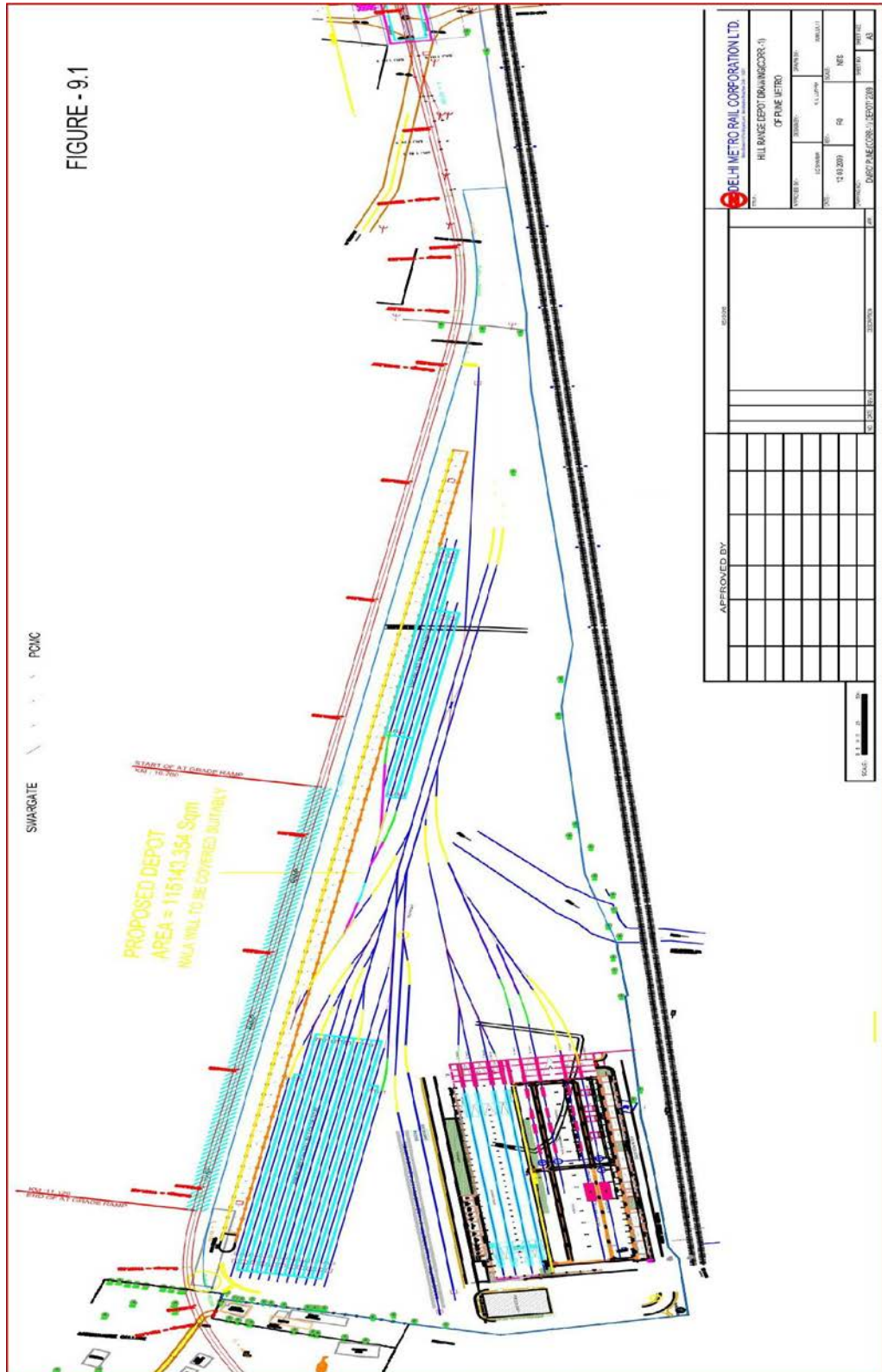
Annexure-IV

**List of Plants& Equipment
Depot - cum- Workshop (Corridor - II)**

S.No.	Equipment	Qty	Unit	Imp/Ind
1.	Under floor Pit wheel lathe, Chip crusher and conveyor for lathe on pit, Electric tractor for movement over under floor wheel lathe	1	Nos	Imp
2.	Under floor lifting system for 3-car unit for replacement of bogie	1+1	Set	Imp
3.	Mobile jacks 15T for lifting cars and locomotive	12+6	Nos	Imp
4.	Re-railing equipment consisting of rail cum road vehicle and associated jack system etc.	1	Set	Imp
5.	Run through type Automatic Washing plant for Metro cars.	1	Nos	Imp
6.	Work lift platform	2	Nos	Imp
7.	Electric bogie tractor for pulling cars and bogies inside workshop	2	Nos	Imp
8.	Compressor for Inspection shed & shop air supply	2	Nos	Ind
9.	Travelling O/H crane Workshop 15T/5T (with auxiliary capacity of 5T)	4	Nos	Ind
10.	Mobile jib crane	4	Nos	Ind
11.	Mobile lifting table	4	Nos	Ind
12.	Car body stands	16+8	Nos	Ind
13.	Bogie turn tables	2	Nos	Ind
14.	AC filter cleaning machine	1	Nos	Ind
15.	Portable cleaning plant for rolling stock	1	Nos	Ind
16.	High-pressure washing pump for front and rear end cleaning of car	2	Nos	Ind
17.	Shot blast cleaner	1	Set	Ind
18.	Paint booth for small parts	1	Set	Ind
19.	Axle shaft inspection station	1	Set	Ind
20.	Storage racks	1	Set	Ind
21.	Industrial furniture	1	L.s.	Ind

S.No.	Equipment	Qty	Unit	Imp/Ind
22.	Minor equipment and collective tools	-	Set	Ind
23.	Induction heater	1	No.	Ind
24.	Oven for the motors	1	No.	Ind
25.	EMU battery charger	2	Nos.	Ind
26.	Welding equipments (Mobile welding, oxyacetelene, fixed arc welding)	1	Set	Ind
27.	Electric and pneumatic tools	-	Set	Ind
28.	Measuring and testing equipment	-	Set	Ind
29.	Tool kits	-	Nos.	Ind
30.	Mobile safety steps	10+5	Nos.	Ind
31.	Fork lift tractor	2	Nos.	Ind
32.	Pallet trucks	4	Nos.	Ind
33.	Diesel/battery Shunting Locomotive	1	Nos.	Ind
34.	Road vehicles (pickup van/ truck)	2	Set	Ind
35.	Miscellaneous office equipments	-	Nos.	Ind

*Additional requirement in the event of reformation of 4 car trains to 6 car trains.



Chapter - 10

Environmental Impact Assessment & Management



- 10.1 Environmental Baseline Data
- 10.2 Location and Physiography
- 10.3 Water and Soil
- 10.4 Geology and Soil
- 10.5 Green Cover
- 10.6 Air Quality
- 10.7 Seismicity
- 10.8 Noise Levels
- 10.9 Socio-Economics
- 10.10 Environmental Impacts
- 10.11 Components of Impact Assessment
- 10.12 Impacts During Construction Phase
- 10.13 Impacts During Operation Phase
- 10.14 Beneficial Impacts of the Proposed Project
- 10.15 Summary of Impacts and Mitigation Measures
- 10.16 Environmental Management Plan
- 10.17 Environmental Monitoring Plan
- 10.18 Environmental Management System



CHAPTER - 10

ENVIRONMENTAL IMPACT ASSESSMENT & MANAGEMENT

10.1 ENVIRONMENTAL BASELINE DATA

The main aim of the EIA study is to establish present environmental conditions along the proposed metro corridors; predict the impacts on relevant environmental attributes due to the construction and operation of the proposed project and recommend adequate mitigation measures to minimize/reduce adverse impacts. The different components of environment in which changes are likely to occur include water, land, air, ecology, noise, socio-economic issues, etc. Majority of data on water quality, vegetation, air and noise quality was collected during field studies in May 2008.

10.2 LOCATION AND PHYSIOGRAPHY

Pune is the first metropolitan centre of Maharashtra and has a population of 2,69,591 as per 2001 census. It is located on NH4, 170km from state capital Mumbai. Positioned at 18°32' N latitude and 73°51' E longitude, at an altitude of 598m. The city is approachable by National Highway NH4 known as Mumbai Pune Highway.

The city lies near the convergence point of rivers Mula and Mutha. The northwestern outskirts of Pune's urban area serve as the crossway for two other rivers, namely Pavana and Indrayani. The Bhima River also flows from the north-western part about 8-9 km away from the main city.

The topography of the city is hilly and uneven. Pune is located 560m (1,837 ft) above sea level on the western margin of the Deccan plateau. It is a relatively hilly city, with its tallest hill rising to 800m (2,625 ft) above sea level. Situating on the leeward side of the Sahyadri mountain range (the Western Ghats), which separate it from the Arabian sea parts of Sahyadri Hills are spread from West to South of the city. Pune is approximately 50 km from the Western Ghats and 100km to the east of the Konkan i.e. the west coast.

The altitude of the city is variable from west to east and north to centre and centre to south. The lowest altitude is 547m above MSL found in the eastern part the highest is more than 820m in the southern part. In the northern area of the city the altitude is 559m to 755m above MSL and in the western part the altitude is rising to more than 750 m above MSL. The central part i.e the main part of the has the altitude within 549-600m above MSL average meteorological condition prevailing at the project route is given in Table 10.1

Table 10.1 - Meteorological Data (IMD)

Table 9.1: Average Meteorological Conditions of 30 yrs data-(1951-1980) of Pune IMD from March-May,2008		
Parameters	Maximum	Minimum
Temperature (°C)	38.1	16.5
Relative Humidity (%)	58	21
Wind Speed (kmph)	10.2	5.7
Wind Direction	Predominant wind direction are W and NW	
Rainfall (mm)	721.7	

Source: Climatological Tables 1951-1980, IMD

10.3 WATER AND SOIL

The water environment refers to the surface and ground water characteristics in the study area. Following section describes the different hydrological characteristics of surface water and groundwater depth or level below the ground level. Water analysis was done for the physico-chemical and biological as per norms. For the groundwater, samples are being collected from the handpumps and tested in the laboratories

10.3.1 Ground Water Table

The groundwater table of the Pune city as collected from the ESR (Environmental Status Report) of PMC (Pune Municipal Corporation) is mentioned in Table 10.2

Table10.2 - Groundwater Table

Sr. No.	Name of Location/Village	Pre-Monsoon			Post-Monsoon		
		2004	2005	2006	2004	2005	2006
1	Katraj	10.8	8.5	6.45	1.75	1.85	-
2	Dhanori	9.4	2.9	2.9	2.4	2.1	-
3	UraliDevachi	6.45	8.4	6	4.5	3.35	-
4	Sus	7.5	6.35	5.8	0.85	0.58	-

Source: ESR Report 2005-06 of PMC(Pune Municipal Corporation)

10.3.2 Ground Water Quality

Ground water samples from 4 representative areas were taken from sources near the alignments and described in Table 10.3.

Table 10.3 - Physico-chemical Characteristics Ground Water Monitoring

Sr. No	Parameters	units	Khadki station	Kunbisahkari Bank (durbankar)	Shivajinagar	Ashoka mall	Bharat petrol pump (karve road)	Agricultural college	Drinking water Desirable
1.	Colour	Hazen	C/L	C/L	C/L	C/L	C/L	C/L	5
2.	Odour	-	U/O	U/O	U/O	U/O	U/O	U/O	U/O
3.	Turbidity	NTU	1	1	1	1	1	1	5
4.	pH	--	7.65	8.05	7.25	7.35	7.46	7.92	6.5-8.5
5.	Conductivity	us/cm	1072	170	420	795	660	692	-
6.	Total Dissolve Solids	mg/l	697	104	265	511	424	450	500
7	Alkalinity as CaCO ₃	mg/l	328	40	116	256	216	232	200
8.	Total Hardness as CaCO ₃	mg/l	368	88	160	256	216	216	300
9	Calcium as Ca	mg/l	115	16	58	96	74	74	75
10	Magnesium as Mg	mg/l	20	12	4	4	8	8	30
11	Bicarbonate	mg/l	400	49	142	312	264	283	
12	Chloride as Cl	mg/l	65	11	22	31	26	37	250
13	Sulphate as SO ₄	mg/l	80	15	34	56	45	40	200
14	Nitrate as NO ₃	mg/l	17	2	6	12	8	8.5	45
15	Fluorides as F	mg/l	1.2	0.6	0.85	0.85	0.75	0.65	1
16	Phenolic compound as C ₆ H ₅ OH	mg/l	BDL	BDL	BDL	BDL	BDL	BDL	0.001
17	Cyanide	mg/l	BDL	BDL	BDL	BDL	BDL	BDL	0.05
18	Aluminium	mg/l	BDL	BDL	BDL	BDL	BDL	BDL	0.03
19	Arsenic	mg/l	BDL	BDL	BDL	BDL	BDL	BDL	0.05
20	Cadmium	mg/l	BDL	BDL	BDL	BDL	BDL	BDL	0.01
21	Chromium as Cr ⁺⁶	mg/l	BDL	BDL	BDL	BDL	BDL	BDL	0.05
22	Iron	mg/l	0.7	0.1	0.16	0.17	0.2	0.15	0.3
23	Copper	mg/l	BDL	BDL	BDL	BDL	BDL	BDL	0.05
24	Lead	mg/l	BDL	BDL	BDL	BDL	BDL	BDL	0.05
25	Manganese	mg/l	BDL	BDL	BDL	BDL	BDL	BDL	0.1
26	Mercury	mg/l	BDL	BDL	BDL	BDL	BDL	BDL	0.001
27	Zinc	mg/l	1	BDL	0.5	1	0.6	0.7	5

Source: Field Monitoring, Note: Units of all the parameters are mg/l except pH, Colour and Turbidity Water

The quality of the well water was inferred in comparison with the National Standards of Drinking Water Quality (IS: 10500, 1992). All the well water samples were colourless, odourless and with agreeable taste. One sample had high turbidity and the samples showed well-balanced pH. The chemical characteristics such as total hardness, chlorides, dissolved solids, sulphates and nitrates were within limits. Among the metals analyzed iron, copper, zinc, chromium, magnesium, cadmium, selenium, mercury and arsenic were not detected or were within stipulated limits.

10.3.3 Surface Water Quality

The source of surface water of Pune is the Mula and Mutha river. The water has been collected from this river at different locations. Table 10.4 describes the Surface water quality of the Pune City as analysed from the samples taken from Mula-Mutha River.

Table 10.4 - Physico-chemical Characteristics Surface Water Monitoring

S. No.	Parameters	Unit	Vitthalwadi (Mutha river)	GarwareBridge (Mula river)	Sangam Bridge (Mutha river)	Bund Garden (Mula -Mutha)	Desirable limit
1	Colour	Hazan	Brownish	Light darkish	Light darkish	Light greyish	5
2	Odour	-	Objection able	Objecti onable	Objecti onable	Objecti onable	U/O
3	Turbidity	NTU	26	32	30	28	5
4	pH	--	7.50	7.35	7.30	7.40	6.5-8.5
5	Conductivity	us/cm	550	640	690	460	-
6	Total Dissolve Solids sum	mg/l	360	448	476	325	
7	Alkalinity as CaCO ₃	mg/l	140	165	173	115	200
8	Total Hardness as CaCo ₃	mg/l	162	188	195	113	300

S. No.	Parameters	Unit	Vitthalwadi (Mutha river)	GarwareBridge (Mutha river)	Sangam Bridge (Mutha river)	Bund Garden (Mutha -Mutha)	Desirable limit
9	Calcium as Ca	mg/l	35	52	60	27	75
10	Magnesium as Mg	mg/l	18	14	11	11	30
11	Sodium	mg/l	29.0	45.0	52.0	21.0	-
12	Potassium	mg/l	8.0	11.0	9.0	11.0	-
13	Bicarbonate	mg/l	171	201	211	140	-
14	Chloride as Cl	mg/l	43	67	58	35	250
15	Sulphate as SO ₄	mg/l	35	42	47	23	200
16	Nitrate as NO ₃	mg/l	3.5	11.4	14	3	45
17	Fluorides as F	mg/l	0.2	0.4	0.5	0.3	1
18	Phenolic compound as C ₆ H ₅ OH	mg/l	BDL	BDL	BDL	BDL	0.001
19	Cyanide	mg/l	BDL	BDL	BDL	BDL	0.05
20	Aluminium	mg/l	BDL	BDL	BDL	BDL	0.03
21	Arsenic	mg/l	BDL	BDL	BDL	BDL	0.05
22	Cadmium	mg/l	BDL	BDL	BDL	BDL	0.01
23	Chromium as Cr+6	mg/l	BDL	0.02	0.035	BDL	0.05
24	Iron	mg/l	0.25	0.6	0.48	0.05	0.3
25	Copper	mg/l	BDL	BDL	BDL	0.02	0.05
26	Lead	mg/l	BDL	BDL	BDL	BDL	0.05
27	Manganese	mg/l	BDL	BDL	BDL	BDL	0.1
28	Mercury	mg/l	BDL	BDL	BDL	BDL	0.001
29	Zinc	mg/l	0.4	1.6	1.5	0.8	5
30	DO	mg/l	1.2	0.6	0.5	2.5	-
31	COD	mg/l	21	35	42	16	-
32	BOD	mg/l	12	12	15	5	-

Source: Field Monitoring

Note: Units of all the parameters are mg/l except pH, colour and Turbidity

10.4 GEOLOGY AND SOIL

Almost the entire morphological strata of the city comprises of stratified trap, beds of basalt and amygdaloid alternate, whose upper and lower planes are strikingly parallel to each other. Barometric measurements and the course of the rivers show a fall in level to the east, and Southeast.

However, soil samples were collected and analyzed and the results are presented in Table 10.5 and 10.6. It is observed that the soil of the project area is sandy loamy to clayey loam in texture and dark grey to dark brown in colour.

Table 10.5 - Soil Type

Sr. No.	Sampling station	sampling code	Soil texture	Sand (%)	Silt (%)	Clay (%)
1	Swargate	S1	Sandy Loam	62	22	16
2	Khadki station	S2	Sandy clayey loam	55	20	25
3	Bund garden	S3	Sandy loam	62	16	22
4	Null stop	S4	Clayey loam	35	33	32
5	Sant tukarnagar	S5	Sandy loam	58	19	23

Source: Field Monitoring

Table 10.6 -Physico-chemical Quality of Soil

S.No.	Parameter	Units	S1	S2	S3	S4	S5
1		Hazan	Brownish	Dark Brownish	Brownish	Dark Brownish	Brownish
2	pH	-	6.8	7.2	7.3	6.9	7.2
3	Soil Texture	-	Sandy Loam	Sandy clay Loam	Sandy Loam	Clay Loam	Sandy Loam
4	Infiltration Rate	Cm/hr	1.35	1.20	1.50	1.10	1.65
5	Bulk Density	gm/cc	1.40	1.58	1.47	1.65	1.48
6	Porosity	%	39	30	41	32	42
7	Moisture content	%	10.5	15.3	12.5	16.8	13.0
8	Organic Carbon	%	0.180	0.350	0.290	0.420	0.200
9	Organic matter	%	0.31	0.60	0.50	0.72	0.34

10	Total Kjeldahl Nitrogen	(%)	0.015	0.028	0.034	0.038	0.022
11	Phosphorus	kg/ha	28	42	70	48	40
12	Potash	Kg /has K %	180	220	246	260	260

Source: Field Monitoring

10.5 GREEN COVER

The proposed corridors do not pass through any reserve/protected forest in its entire length. Moreover, no forests are found in its indirect impact zone as well (7km radius). However, significant amounts of road side vegetation are observed in 20m band of metro corridor. There are over 2500 trees along the project site. The main trees which were found on the site are, Eucalyptus, Sisham, Toot, Arjun, Neem, Pipal, Banyan, Baigad, Kassod. Copper pod (Peltophorum ferruginum), Gulmohar (Delonixregia), Silver Oak (Grevillea robusta), Bottle palm (Roystonearegia), Asoka (Polyalthialongifolia var. pendula) Fountain tulip (Spathodeacompanulata) Sayami Cassia (Cassia siamea) Neelmohor (Jacaranda mimisaefolia) and Cork (Millingtoniahortensis), &Mangniferaindica.

10.6 AIR QUALITY

As part of the study, ambient air quality monitoring has been carried out by setting up ambient air quality monitoring stations at 8 locations for the parameters SPM, RPM, SO₂ andNO_x. The ambient air quality stations were selected taking into the view of traffic flow and strategic locations on the proposed metro rail route. Sampling was done during May 2008 at the 5 locations along the proposed alignment. The sampling locations are given in Table 10.7.

Table 10.7 - Details of AAQ Monitoring Locations

Sr. No.	Name of the code	Name of Location/village
1	AAQ1	Karve road
2	AAQ2	Pimpri-Chinchwad
3	AAQ3	Swargate
4	AAQ4	Nalstop
5	AAQ5	.Khadki Railway station
6	AAQ6	Agricultural University
7	AAQ7	Law College

Source: Field monitoring

The air quality as monitored is given in Table 10.8.

Table 10.8 - Overall Baseline ambient Air Quality

Standards (Concentration in $\mu\text{g}/\text{mg}^3$) 24 hours**	98 th Percentile Values ($\mu\text{g}/\text{mg}^3$)			
	SPM	RSPM	SO ₂	NO _x
<i>Industrial Area</i>	500	150	120	120
<i>Residential, Rural & Other Areas</i>	200	100	80	80
<i>Sensitive Areas</i>	100	75	0	30
Village Name	SPM	RSPM	SO ₂	NO _x
Karve road	170.0	64.0	12.5	15.0
Pimprichinchwad	176.0	68.5	18.0	20.0
Swargate	296.5	93.0	30.5	48.5
Nalstop	293.0	95.5	38.0	42.5
Khadki Railway station	169.5	63.0	15.0	13.0
Agricultural University	158.5	54.0	15.0	15.0
Law College	132.0	44.0	11.0	11.0
** 24 hourly/ 8 hourly values should be met 98% of the time of the year. However 2% of the time it may exceed but not on two consecutive days				

With respect to pollutants the results of the monitoring program indicate the following:

- Levels of SPM are high and exceed NAAQS. SPM levels exceeded the NAAQS (Annual Average) in residential areas whereas in industrial areas they were within the NAAQS (Annual Average).
- Levels of RSPM are well within the limits of NAAQS.
- Levels of SO₂ are well within the prescribed limits of NAAQS at all receptors.
- Levels of NO_x are also within prescribed limit at some receptors, while at some places like Swargate and Nalstop the values are slightly high.

10.7 SEISMICITY

The City spans over an area of 146 square kilometres with around 40 per cent of area under greenery. Pune lies in the seismically active zone of Koyana Region, which is about 100 km

south of the city. Pune has experienced some moderate-intensity and many low-intensity earthquakes.

10.8 NOISE LEVELS

The noise levels were measured at 7 locations along the project alignment at 1.0 km away from the source as per standard practice. The noise level ranges are summarized in Table 10.9. It could be concluded that the noise levels recorded at various stations are generally higher than the permissible level of 65db (day) and 55db (night) for commercial areas and 55db (day) and 45db (night) for residential areas.

Table-10.9 - Noise levels at different Location

Noise Location	Day						Night					
	L Max	L Min	Leq	L10	L50	L90	L Max	L Min	Leq	L10	L50	L90
Karve road	72	63	68.58	70.5	68	65	65	56	62.02	65	61	57.4
Pimpri – chinchwad	72	61	67.48	70	66.5	63.5	64	54	60.54	64	59	55.4
Swargate	68	62	65.40	67	65.5	63	65	57	61.24	63.6	60.5	57
Nalstop	73	68	70.67	72	70	68	67	61	64.35	67	63.5	61
Khadki railway station	70	62	66.66	69	66	63.5	62	57	60.01	62	59.5	57
Agricultural university	70	62	67.09	69.5	66.5	63	64	58	61.95	64	61.5	58.7
Law college	67	55	62.62	65.5	62	56	62	53	58.33	61.3	57	53.7

Source: Field monitoring

10.9 SOCIO-ECONOMICS

The population of Pune City is 2695911 as per 2001 census. Rapid industrialization of the area led to high population growth since independence and has led to a high population density. The city is divided into three subdivisions viz. Kirkee Extension(Cantonment Board), Pune Cantonment and Pune Municipal Corporation area. Table 10.10 depicts the demographic profile of the Pune city.

Table 10.10 - Demographic Profile of Pune city

Parameters	Kirkee (CB)	Pune (CB)	Pune (M.corp.)	Total
Total population	77,473	79965	2,538,473	2695911
Male	43,386	41,241	1321,338	1405965
Female	34087	38,724	1,217,135	1289946
Population under 6 years of age	8776	79965	302,960	391701
Male	4694	4240	158,672	167606
Female	4082	4042	144,288	152412
Sex ratio	786	939	921	2646
Sex ratio (0-6)	870	953	909	2732

Source: census of India 2001

From Table 9.9, it can be observed that the gender ratio of the area is low and stands at 786. This is due the general low gender ratio in Maharashtra and also the high rate of in-migration to the city of labourers who come alone and leave their families behind in the villages. The population below 6 years was also found to be low.

The Literacy rate of the area is quite high and stands at 88.9%. The female literacy rate of the study area which is 87.73% is lower than the male literacy rate.

The economy of the city and its local planning area is based mainly on trade and commerce and on manufacturing industries including hosiery, cycle, sewing machines, textiles and other industries. Real estates, financial and banking services also contribute to the economic wellbeing of the city.

10.10 ENVIRONMENTAL IMPACTS

Based on the project particulars and existing environmental conditions potential impacts have been identified that are likely to result from the proposed metro rail project. The positive environmental impacts includes reduction in traffic congestion, quick service and safety, less fuel consumption, reduction in air pollution, reduction of noise level and Better roads

10.11 COMPONENTS OF IMPACT ASSESSMENT

The construction and operational phase of the proposed project comprises various activities each of which may have an impact on environmental parameters. Various impacts during the construction and operation phase on the environment have been studied to estimate the impact on the environmental attributes and are discussed in the subsequent section. The probable impacts of each of these activities on various sectors of environment have been mentioned below under three headings:

- Impacts due to Project Location
- Impacts during Construction Phase
- Impacts during Operational Phase

All the potentially significant environmental impacts from the project are tabulated as below in Table 10.11

Table 10.11 – Potential Significant Environment Impacts

S. No.	Parameters	Negative Impact	Positive Impact	No Impact
A. Impacts due to Project Location				
i.	Change of land use	<input type="checkbox"/>		
ii.	Loss of trees/vegetation	<input type="checkbox"/>		
iii.	Impact on archeological property			<input type="checkbox"/>
B. Impacts due to Project Construction				
i.	Soil Erosion, pollution and health risk at construction site	<input type="checkbox"/>		
ii.	Traffic Diversion and risk to existing buildings	<input type="checkbox"/>		
iii.	Impact on water Quality			<input type="checkbox"/>
C. Impact during Project operation				
i	Oil Pollution			<input type="checkbox"/>
ii	Noise and vibration	<input type="checkbox"/>		
iii	Accidental Hazards			<input type="checkbox"/>
iv	Water Supply			<input type="checkbox"/>
v.	Metro station refuse			<input type="checkbox"/>
vi.	Visual Impact			<input type="checkbox"/>
D. Positive Impact				
i	Traffic congestion		<input type="checkbox"/>	
ii	Quick Service and safety		<input type="checkbox"/>	
iii	Less fuel consumption		<input type="checkbox"/>	

S. No.	Parameters	Negative Impact	Positive Impact	No Impact
iv	Better roads		<input type="checkbox"/>	
v	Reduction in air pollution		<input type="checkbox"/>	
vi	Employment opportunity		<input type="checkbox"/>	

10.11.1 Land-Use Changes

The align will not have much affect on the land use of the city. The alignment contains both elevated and underground section along the road divider. Some residential and commercial buildings will be affected situated on the route of the alignment.

10.11.2 Loss of trees

The proposed metro lines are in urban/ city area and will not pass through any forests. However, due to the proposed metro construction about **685 mature trees are likely to be lost**.With removal of these trees the process for CO₂ conversion will get effected and the losses are reported below:

Total Number of Mature Trees	About 685
Decrease in CO ₂ absorption @ 21.8kg per year /tree for 8 years	161843kg
Oxygen production @ 49kg per year /tree for 8 years	363776kg

The total value of these trees lost is Rs. 8.22lacs as shown in table below:-

Total Loss of trees (No.)	
Average cost of one tree (Rs.)	
Total Loss (Rs.)	Rs. 8.22 lacs

The main species are Githithi, Babul, Seshum, Neem, Peepal, Keekar, Pilkhan, Kakri, Chokar, Laspasia, Sahtut, Bargad, Gulmohar, Baikan, Rudrakash, etc.

10.11.3 Displacement of the people

There will be land acquisition only near the underground stations and places where there will be interchanges. It has been estimated after preliminary survey that there will be 480 structures affected due to land acquisition.

10.11.4 Shifting of Utilities and Drainages

There will be shifting of existing water supply pipelines, electrical lines and sewerage lines. There is surface water body such as drains and canals joining the Mula and Mutha

River cutting the proposed corridor. Therefore cross drainage works such as bridges, culverts etc. will be required. Since this will affect construction and project implementation time schedule/costs for which necessary planning/action needs to be initiated in advance.

10.12 IMPACT DURING CONSTRUCTION PHASE

The most likely negative impacts related to the construction works are given below.

- Pressure on local Infrastructure
- Soil erosion problems
- Solid Waste Generation
- Health risk at construction site,
- Traffic congestion and diversion problems,
- Excavated and Construction material Disposal problems,
- Water Contamination Problems
- Impact on Air Quality
- Impact on Noise Quality
- Displacement.

10.12.1 Pressure on Local Infrastructure

Considering the nature and the magnitude of the project, impact shall be short term and low in magnitude and are limited to construction phase only.

10.12.2 Soil Erosion

The vegetation and top soil shall be disturbed during the construction stage due to excavation and movement of vehicles and equipment. The spillage of oil from machinery or cement residual from concrete mixer plants might contaminate the soil if not properly collected and disposed off.

10.12.3 Solid waste Generation

Problems could arise from dumping of construction spoils (Concrete, bricks) waste materials (from contractor camps) etc. causing surface and ground water pollution. However, it is proposed to have mix concrete directly from batching plant for use at site. Batching plants will be located away from the site. The other construction material such as steel, bricks, etc. will be housed in a fenced stored yard. The balance material from these yards will be removed for use/disposal.

10.12.4 Health Risk at Construction Site

At the project site direct exposure to dust generation is likely to cause health related impact especially dust related diseases. This would be minimized by providing suitable respiratory personal protective equipments (PPE) such as nose mask with suitable filters etc.

10.12.5 Traffic Congestion and Diversion Problems

Most of the roads of the project area are broad with traffic signals in proper places but in some areas has congested stretches where traffic movement is very slow and roads are very narrow. Hence, traffic congestion during the construction phase will be a major issue.

10.12.6 Water Contamination Problems

Within the vicinity of project site no major / designated water body except one irrigation canal are present. Also since all construction related activities will primarily be confined to the enclosed corridor, hence no major impacts are anticipated.

10.12.7 Impact on Air quality

Potential impacts on the air quality during the construction stage will be due to the fugitive dust and the exhaust gases generated in and around the construction site.

10.12.8 Impact on Noise Quality

Due to the various construction activities, there will be short-term noise impacts in the immediate vicinity of the project corridor. The impact will be felt more in the congested areas where utmost care has to be taken to reduce noise generation by using acoustic enclosures.

10.12.9 Social Impact

As local labours will be hired from the vicinity of the project site and shall be utilized for the construction purpose and all the activities shall be confined to the project site only, hence no adverse social impacts are envisaged due to the proposed project.

10.13 IMPACT DURING OPERATION PHASE

The project may cause the following negative impacts during operation of the project due to the increase in the number of passengers and trains at the stations:

- Impact on Land Environment
- Noise pollution,
- Water supply and sanitation at Stations,
- Refuse disposal and sanitation, and
- Visual Issues

10.13.1 Impact on Land Environment

As the metro corridor will pass through some congested stretches of residential/commercial areas, there would be increased scope for commercial, industrial and residential development along the project corridor.

10.13.2 Noise Pollution

The maximum noise level has been estimated as 64 dB(A) including background noise level as 20 dB(A) inside the Metro Noise level at a distance of 12.5m, 25m, and 50m from the alignment have been calculated similarly and these comes out to be 57.2, 54.2 and 45.2 dB(A) respectively.

10.13.3 Impact on Water System

Thus the water demand on one station works out to be about 11kld, out of them 7.5 kld wastewater will be generated at each station that will be treated in the treatment plant. In addition, water will be required for contractor's camps during construction.

10.14 BENEFICIAL IMPACTS OF THE PROPOSED PROJECT

Positive impacts have been listed under the following headings:

- Employment Opportunities
- Less Air Pollution
- Quick Service and Safety
- Less Fuel Consumption and Carbon Dioxide Reduction

10.14.1 Employment Opportunities

The project is expected to generate employment in the secondary and tertiary sector during construction and operation phase. During the construction phase, there will be requirements for unskilled labourers.

10.14.2 Less Air Pollution

Introduction of Mass Rapid Transport System will reduce the traffic load on the roads. Many vehicle owners and users of auto-rickshaw will shift to metro rail as it will be a faster and convenient mode of transport. Thus reduction of traffic will lead to reduction of automobile emission and consequently air pollution.

10.14.3 Quick Service and Safety

The metro rail system would be more efficient and faster as compared to the traditional mode of travel. Also reduction of congestion will make the roads safer and will reduce the incidence of accidents.

10.14.4 Less Fuel Consumption

Reduction of cars and other forms of personal vehicles will help in reduction of fuel consumption in the city.

10.15 SUMMARY OF IMPACTS AND MITIGATION MEASURES

A summary of the potential environmental impacts during construction and operation phase along with recommended mitigation measures is presented in matrix format in Table 10.12.

Table 10.12 - Environmental Impacts and Mitigation Measures

Area	Impacts	Mitigation Measures
Construction Phase		
Topography and geology	<ul style="list-style-type: none"> Change in existing profile of the land-use Disturbance on geological setting due to quarrying. 	<ul style="list-style-type: none"> Suitable seismic design of the proposed corridor structures will be adopted to mitigate the earthquake impacts.
Soil	<ul style="list-style-type: none"> Loosening of soil due to excavation, resulting increased soil erosion. 	<ul style="list-style-type: none"> Adequate drainage, embankment consolidation & slope stabilization will be taken along the road to avoid soil erosion.
Water use	<ul style="list-style-type: none"> Impact on the local water sources due to use of construction water. 	<ul style="list-style-type: none"> Maximum rainwater harvesting and minimum use of existing water sources for construction will be ensured to minimize likely impacts on other users.

Area	Impacts	Mitigation Measures
Water quality	<ul style="list-style-type: none"> • Increase of sediment load in the run off from construction sites • Water pollution due to sewage from construction camps. 	<ul style="list-style-type: none"> • Sediment traps will be provided to reduce sediment load in construction wastewater. • Proper sanitation facilities will be provided in construction camps.
Air quality	<ul style="list-style-type: none"> • Deterioration of air quality due to fugitive dusts emission from construction activities and vehicular movement along unpaved roads. • Deterioration of air quality due to gaseous emissions from construction equipment & vehicular traffic. • Deterioration of air quality due to emission from asphalt and hot mix plants. 	<ul style="list-style-type: none"> • Construction materials will be stored in enclosed spaces to prevent fugitive emissions. • Truck carrying soil, sand and stone will be duly covered to avoid spilling. • Adequate dust suppression measures will be undertaken to control fugitive dust. • Low emission construction equipment & vehicles will be used.
Noise level	<ul style="list-style-type: none"> • Increase in noise level due to operation of construction equipment & vehicular traffic. 	<ul style="list-style-type: none"> • Protective gears such as ear plugs etc. will be provided to construction personnel exposed to high noise levels as preventive measure. • Low noise construction equipment will be used. • Construction activities carried out near residential area will be scheduled to the day time only so that minimum disturbances are caused to people.
Floral & fauna	<ul style="list-style-type: none"> • Loss of 900 trees due to construction of proposed Metro corridor 	<ul style="list-style-type: none"> • Preferential plantation of flowering trees with less timber & fruit value will be carried out. • Cooking fuel will be provided to construction workers to avoid cutting/felling of trees for fuel wood. • Compensatory trees cost of compensatory afforestation will be provided.
Rehabilitation & resettlement	<ul style="list-style-type: none"> • No Impact will take Place 	

Area	Impacts	Mitigation Measures
Employment and trading opportunities	<ul style="list-style-type: none"> The construction will improve the job opportunities 	<ul style="list-style-type: none"> Most of the construction labourers will be recruited from local areas to alleviate social tension of migration. Some of the construction materials like stone chips & sand will be procured locally.
Operation Phase		
Land-use & Encroachment	<ul style="list-style-type: none"> Change of land use by squatter/ encroachment within ROW and induced development outside the ROW. 	<ul style="list-style-type: none"> Planning agencies and Collector/ Revenue Officer will be made involved for controlled development and prohibiting squatter/ encroachment within ROW.
Drainage	<ul style="list-style-type: none"> Filthy environment due to improper maintenance of drainage. 	<ul style="list-style-type: none"> Drainage system will be properly maintained.
Air quality	<ul style="list-style-type: none"> The proposed project will provide a reduced vehicular emission load atmosphere 	
Noise level	<ul style="list-style-type: none"> Noise pollution due to operation phase of proposed Metro rail corridor 	<ul style="list-style-type: none"> Regular monitoring of noise level at specified locations will be conducted.
Access	<ul style="list-style-type: none"> The proposed corridor will help to increase the accessibility of the project site 	
Road safety	<ul style="list-style-type: none"> Less vehicular movement will result to less accidental scenario 	<ul style="list-style-type: none"> Road signs, road markings, kerb paintings and road furniture like overhead gantry signs, roadway delineators etc. will be provided. Adequate illumination will be provided at interchange locations Periodical inspection of the corridor will be conducted to detect anomalies in pavement.

10.16 ENVIRONMENTAL MANAGEMENT PLAN

Based on the environmental baseline conditions, planned project activities and its impact assessed, which needs to be taken to implemented are given in this section.

10.16.1 Mitigation Measures

Based on the project description, environmental baseline data and environmental impacts, it is proposed to prepare the environmental management plan for the following:

- a) Compensation for loss of land
- b) Compensation for loss of trees
- c) Compensatory afforestation and fencing
- d) Compensation for relocation / resettlement
- e) Water supply and sanitation
- f) Noise control
- g) Vibration control

a) Compensation for loss of land

The cost of land for compensation is taken under the project cost.

b) Compensation for loss of trees

Compensation will be given for all trees which will be destroyed during construction activity.

c) Compensatory afforestation

According to survey, about 685 trees are likely to be lost due to the project along the alignment. Five times the number of trees is proposed to be planted. Hence near about 3425 plants are required to be planted in the project area at a total cost of Rs. 1 lakh. It is presumed that government land will be provided for afforestation; hence no land cost will be involved.

d) Compensation for relocation/resettlement

The project involves relocation of shops, commercial cum residential buildings along the alignment. Compensation will be paid as per Government policy.

e) Water supply and sanitation

The public health facilities such as water supply sanitation and toilets are much needed at project location. Water should be treated before use up to WHO standards. In addition, water will be required for contractor's camps during construction for which additional arrangements have to be made in consultation with the Corporation of Pune. The collection and safe disposal of human wastes are among the most important problems of environmental health. During the operation phase, adequate water supply and sanitation facilities would be made available at all the stations.

Properly designed rain water harvesting systems will be installed at all stations to conserve water.

f) Noise

There will be an increase in noise level in ambient air due to construction and operation of metro rail. The increase in levels is marginal; hence local population will not be adversely affected. However, the exposure of workers to high noise levels especially near engine, vent shaft, etc. need to be minimized. This can be achieved by job rotation, automation, protective devices, noise barriers, and soundproof compartments, control rooms, etc. The workers employed in high noise level area could be employed in low noise level areas. Automation of equipment and machineries, wherever possible should be done to avoid continuous exposure of workers to noise. At work places, where automation of machineries is not possible, the workers exposed to noise should be provided with protective devices. Special acoustic enclosures should be provided for individual noise generating equipments, wherever possible.

g) Vibration control

Vibration emanates from rail-wheel interaction and the same can be reduced by minimizing surface irregularities of wheel and rail, improving track geometry, providing elastic fastenings, and separation of rail seat assembly from the concrete plinth with insertion of resilient and shock absorbing pad.

10.17 ENVIRONMENTAL MONITORING PLAN

The environmental monitoring will be required for the construction and operational phases. The parameters to be monitored are water quality, air quality and noise level.

a) Water quality

Water quality parameters can be monitored one year before the construction, during the construction phase and also for one year after the completion of the project. Monitoring shall be carried out at least four times a year to cover seasonal variations. The parameters for monitoring will be pH, total dissolved solids, chlorides, nitrates, sulphates, total suspended solids, calcium, iron, fluoride, total alkalinity, oil and grease, etc. Locations for monitoring can be decided after the construction phase. The cost of water quality analysis for four locations works out to be Rs 4.00 lakhs.

b) Air quality and noise level

Ambient air quality and noise level should be monitored one year before the construction, during the construction phase, and for one year after the completion of the project. The proposed monitoring program for field monitoring and laboratory analysis of air and noise is given in Table 24. The cost of ambient air quality and noise level monitoring works out to be Rs 15.20 lakhs.

10.18 ENVIRONMENTAL MANAGEMENT SYSTEM

The environmental management system constitutes provision of an environmental division, which should be staffed by an environmental engineer/officer, an environmental assistant and two other assistants. The task assigned should include supervision and coordination of monitoring and implementation of environmental mitigation measures. An environmental advisor shall review progress of the division every year.

Chapter - 11

Cost Estimates



- 11.1 Introduction
- 11.2 Capital Cost Estimate Corridor-I
- 11.3 Capital Cost Estimate Corridor-II
- 11.4 Civil Engineering Works
- 11.5 Depot
- 11.6 Utility Diversions
- 11.7 Environmental Impact Assessment
- 11.8 Rehabilitation and Resettlement
- 11.9 Traction and Power Supply
- 11.10 General Charges and Contingences
- 11.11 Signalling and Telecommunication Works
- 11.12 Automatic Fare Collection
- 11.13 Rolling Stock
- 11.14 Taxes and Duties

CHAPTER - 11



COST ESTIMATES

11.1 INTRODUCTION

Detailed cost estimates for Corridor-1 (PCMC - Swargate) and Corridor-2 (Vanaz – Ramvadi) have been prepared covering civil, electrical, signalling and telecommunications works, rolling stock, environmental protection, rehabilitation, etc. considering 25 kV ac Overhead Traction System at November 2015 price level.

While preparing the capital cost estimates, various items have generally been grouped under three major heads on the basis of (i) route km length of alignment, (ii) number of units of that item, and (iii) item being an independent entity. All items related with alignment, whether elevated or at-grade or underground construction, permanent way, traction, Signalling & telecommunication, whether in main lines or in maintenance depot, have been estimated at rate per route km basis. Cost of station structures, other electrical services at these stations including Lifts & Escalators and automatic fare collection (AFC) installations at all stations have been assessed in terms of each station as a unit. Similarly Rolling stock costs have been estimated in terms of number of units required. In remaining items, viz. land, utility diversions, rehabilitation, etc. the costs have been assessed on the basis of each item, taken as an independent entity.

In order to arrive at realistic cost of various items, costs have been assessed on the basis of accepted rates in various contracts recently awarded by DMRC for their ongoing works of Phase-III duly correcting them for the system proposed for the Pune Metro. A suitable escalation factor has been applied to bring these costs to November 2015 price level. In some of the tenders, there is an element of taxes, which has been excluded for working out the project cost. However the details of taxes and duties are worked out separately.

The capital cost has been worked out for Corridor-1 and Corridor-2 with Depots near Hill Range station for Corridor-1 and at Kothrud (Kachara depot) near Vanaz station for Corridor -2.

11.2 CAPITAL COST ESTIMATE –CORRIDOR 1

The overall capital cost for PCMC - Swargate Corridor, at November 2015 price level, works out to Rs.5333 crores, excluding taxes and duties, but including general charges & design charges @ 5% on all items except land and 3% contingencies on all items. The abstract capital cost estimates are shown at Table below:-

**Table 0.10 - Capital Cost Estimate of PCMC – Swargate (Corridor I)
(November 2015 Price Level)**

Nov 2015 Prices

Corridor I (PCMC-SEWARGATE SECTION)					
Total length = 16.589 km, UG= 5.019 km (TBM = 4.114 km, C&C = 0.905 km), Elv = 11.570 km					
Total Station = 15 nos, UG = 6, Elv =9					
S. No.	Item	Unit	Rate	Qty.	Amount (Rs. in Cr.)
Without taxes					
1.0	Land				503.94
1.1	R & R incl. Hutments etc.	R Km	3.55	17.589	62.40
	Sub Total (1)				566.34
2.0	Alignment and Formation				
2.1	Underground section by T.B.M excluding station length (260m each)	R. Km.	150.00	3.074	461.10
2.2	Underground section by Cut & Cover excluding Station length (260m each)	R. Km.	100.00	0.385	38.50
2.3	Elevated section including station length	R. Km.	33.00	11.570	381.81
2.4	Entry to depot at grade	R. Km.	19.80	1.000	19.80
	Sub Total (2)				901.21
3.0	Station Buildings				
3.1	Underground Station(260 m length) incl. EM works, lifts, escalators, VAC etc.	Each			
a	Underground Station- Civil works	Each	150.00	6.000	900.00
b	Underground Station- EM works etc.	Each	60.00	6.000	360.00
3.2	Elevated stations	Each			
a	Type (A) way side- civil works	Each	26.00	5.000	130.00
b	Type (A) way side- EM works etc	Each	11.81	5.000	59.05

c	Type (B) Way side with signalling-civil works	Each	25.89	2.000	51.78
d	Type (B) Way side with signalling-EM works etc	Each	11.81	2.000	23.62
e	Type (C), Terminal station -civil works	Each	29.01	2.000	58.02
f	Type (c), Terminal station -EM works	Each	11.81	2.000	23.62
3.3	Metro Bhawan& OCC bldg.	LS			
a	Metro Bhawan& OCC bldg.-civil works	LS			56.25
b	Metro Bhawan& OCC bldg.-EM works etc	LS			18.75
	Sub Total (3)				1681.09
4.0	Depot	LS			
a	Civil works	LS			100.00
b	EM works etc	LS			50.00
	Sub total (4)				150.00
5.0	P-Way				
5.1	Ballastless track for elevated & underground Section	R. Km.	7.85	16.589	130.22
5.2	Ballasted track for at grade alignment in depots	R. Km.	3.93	5.000	19.63
	Sub total (5)				149.85
6.0	Traction & power supply incl. OHE, ASS etc. Excl. lifts & Escalators				
6.1	UG Section	R.Km.	15.39	5.019	77.25
6.1	Elevated & at grade section	R.Km.	10.34	12.570	129.98
	Sub total (6)				207.23
7.0	Signalling and Telecom.				
7.1	Sig. & Telecom.	R. Km.	15.73	17.589	276.63
7.2	Automatic fare collection	Stn.			
	a)Underground section	Each	5.41	6.000	32.45
	b) Elevated stations	Each	5.41	9.000	48.67
	Sub Total (7)				357.75
8.0	Misc. Utilities, roadworks, other civil works such as median stn.signages Environmental protection	R. Km.			
a	Civil works+EM works	R. Km.	7.18	16.589	119.15
	Sub Total (9)				119.15
9.0	Rolling Stock	Each	10.60	76.000	805.62
	Sub Total (10)				805.62
10.0	Capital expenditure on security	LS			
a	Civil works	LS			12.00
b	EM works etc	LS			8.00
	Sub Total (11)				20.00

11.0	Total of all items except Land				4391.90
12.0	General Charges incl. Design charges @ 5 % on all items except land				219.60
13.0	Total of all items including G. Charges except land				4611.50
14.0	Contingencies @ 3 %				138.34
15.0	Gross Total				4749.84
Cost without land					= 4750
Cost with land					= 5333

11.3 CAPITAL COST ESTIMATE –CORRIDOR 2

The overall capital cost for Vanaz – Ramvadi Corridor at November 2015 price level, works out to Rs. 2794 crores, excluding taxes and duties, but including general charges & design charges @ 5% on all items except land and 3% contingencies on all items. The abstract capital cost estimates are shown at Table below:-

PUNE METRO Capital Cost Estimate

November 2015 Prices

Corridor II (VANAZ-RAMVADI SECTION)					
Total length = 14.665 km, UG= 0 km , Elv = 14.665 km					
Total Station = 16 nos, UG = 0, Elv =15					
S. No.	Item	Unit	Rate	Qty.	Amount (Rs. in Cr.)
Without taxes					
1.0	Land				282.77
1.1	R & R incl. Hutments etc.	R. Km.	3.55	15.665	55.58
Sub Total (1)					338.35
2.0	Alignment and Formation				
2.1	Elevated section including station length	R. Km.	33.00	14.665	483.97
2.2	Entry to depot at grade	R. Km.	19.80	1.000	19.80
Sub Total (2)					503.77
3.0	Station Buildings				
3.2	Elevated stations	Each			
a	Type (A) way side- civil works	Each	26.00	12.000	312.04
b	Type (A) way side- EM works etc	Each	11.81	12.000	141.69
c	Type (B) Way side with signalling-civil works	Each	25.89	2.000	51.78

d	Type (B) Way side with signalling-EM works etc	Each	11.81	2.000	23.62
e	Type (C), Terminal station -civil works	Each	29.01	2.000	58.02
f	Type (c), Terminal station -EM works	Each	11.81	2.000	23.62
3.3	Metro Bhawan& OCC bldg.	LS			
a	Metro Bhawan& OCC bldg.-civil works	LS			0.00
b	Metro Bhawan& OCC bldg.-EM works etc	LS			0.00
	Sub Total (3)				610.76
4.0	Depot	LS			
a	Civil works	LS			100.00
b	EM works etc	LS			50.00
	Sub total (4)				150.00
5.0	P-Way				
5.1	Ballastless track for elevated & underground Section	R. Km.	7.85	14.665	115.16
5.2	Ballasted track for at grade alignment in depots	R. Km.	3.93	5.000	19.63
	Sub total (5)				134.79
6.0	Traction & power supply incl. OHE, ASS etc. Excl. lifts & Escalators				
6.1	Elevated & at grade section	R.Km.	10.34	15.665	161.99
	Sub total (6)				161.99
7.0	Signalling and Telecom.				
7.1	Sig. & Telecom.	R. Km.	15.73	15.665	246.37
7.2	Automatic fare collection	Stn.			
	Elevated stations	Each	5.41	15.000	81.12
	Sub Total (7)				327.49
8.0	Misc. Utilities, roadworks, other civil works such as median stn.signages Environmental protection	R. Km.			
a	Civil works+EM works	R. Km.	3.79	14.665	55.57
	Sub Total (9)				55.57
9.0	Rolling Stock	Each	10.60	28.000	296.81
	Sub Total (10)				296.81
10.0	Capital expenditure on security	LS			
a	Civil works	LS			12.00
b	EM works etc	LS			8.00
	Sub Total (11)				20.00
11.0	Total of all items except Land				2261.18
12.0	General Charges incl. Design charges @ 5 % on all items except land				113.06

13.0	Total of all items including G. Charges except land				2374.23
14.0	Contingencies @ 3 %				71.23
15.0	Gross Total				2445.46
Cost without land					= 2445
Cost with land					= 2794

11.4 CIVIL ENGINEERING WORKS

11.4.1 Land

- i) Land requirements have been kept to the barest minimum & worked out on area basis. For underground and elevated alignment, no land is proposed to be acquired permanently, except small areas for locating entry/exit structures, traffic integration, etc. at stations, and wherever the alignment is off the road.
- ii) Major area 31.64 Ha of land proposed to be acquired is of Govt. land including 11.51 Ha. for Agricultural University Area depot and 12.11 Ha. For Kothrud Depot. In addition to this, 12.62.Ha private land is proposed to be acquired.
- iii) In addition to the lands required permanently, 9.5 Ha of private land is temporarily required for construction depots. Ground rent charges for 3 years @ 6% per year of the cost of land have been provided for, in the project cost estimates.
- iv) Total land requirements for Corridor -1 have been worked out to 17.47 Ha. of Govt. land and 17.34 for Corridor -2 land requirements have been worked out to 14.17 Ha of Govt. land and 4.78 Ha of Private land including 12.11 Ha for car maintenance depot at Kothrud and 0.5 Ha. for temporary construction depot.
- v) It is envisaged that requirement of land remain same for underground and elevated options as no acquisition of land (except off the road locations) is proposed in running section of viaduct in case elevated sections. Requirement of land at station locations is increased marginally in case of underground sections as certain facilities such as DG set, Chilling Plant, Pump House and cooling Towers are required to be constructed at surface. Land required for depots and construction depots remains same in both the cases
- vi) Maharashtra Infrastructure Development Board (MIDB) has identified 23.96 Ha of land for Property Development. However, only 6.44 Ha land has been considered for funding the project after its commercial exploitation. The small plots identified have not been considered since the Developer will not like to take up property development in small plot areas at several locations. In addition to 6.44Ha land, it is assumed that the FAR equivalent 4.0 Ha of the land at University Depot will also be made available

for Property Development for funding the project. The total land area considered for property development for funding of project is 10.44 Ha. The property development shall be taken either by BOT operator or private agency.

- vii) Details of Land requirement and its cost are given at Table No. 11.3, 11.4 and 11.5.

11.4.2 Formation, Alignment

- i) **Underground section:-** Rates adopted are based on the cost assessed for Delhi-Metro works underground alignment. Cost are worked considering underground alignment to be done by Tunnel Boring Machines, except 260m lengths for each station, which is proposed to be done along with station work. All the stations are proposed to be constructed by cut & cover method.
- ii) **Elevated Section:** Rates are based on accepted rates for ongoing works of Delhi Metro, duly updated to November 2015 price level. Cost of viaduct length for station has been included in elevated section.

11.4.3 Station Buildings

- i) **Underground Stations:** Rates for underground stations are based on cost assessed for similar works for Delhi Metro Station works duly updated to November 2015 price level. This work cover U.G. alignment, as well as, other civil electrical works like ventilation, air-conditioning, lifts & escalators, but does not cover P-way, O.H.E, signaling and interlocking works, AFC installations.
- ii) **Elevated Stations:** Estimated rate is based on accepted rates for stations on Delhi Metro, duly updated to November 2015 price level. The cost includes the general services at the stations but excludes the cost of viaduct, lifts & escalators, which have been considered separately under, respective items.

11.4.4 Permanent Way

For elevated and underground sections, ballastless track and for at-grade section and Depot ballasted track has been planned. Rates adopted are based on accepted rates for ongoing works of Delhi Metro, duly updated to November 2015 price level and duly corrected for the systems proposed for Pune Metro.

11.5 DEPOT

Separate Car Maintenance Depot-cum-Workshop for Corridor-1 and Corridor-2 have been proposed at Agricultural University area and Kothrud respectively. The two depots are

planned at ground level. Costs have been worked out for various items of building, elevated structures, tracks, boundary wall & plants machinery etc.

11.6 UTILITY DIVERSIONS

The costs of utility diversions involved in the stretch have been considered separately and provided for in the estimate. In addition to sewer/drainage/water pipelines other important utilities works considered are road diversions, road restoration etc. Cost provision has been made on route km basis based on experience of Delhi Metro.

11.7 ENVIRONMENTAL IMPACT ASSESSMENT

Provision for environmental impacts of the proposed two Corridors of Pune Metro has been made to cover various protection works, additional compensatory measures, compensation for loss of trees, compensatory affore station and fencing, monitoring of water quality, air/noise pollution during construction, establishment of Environmental Division.

11.8 REHABILITATION & RESETTLEMENT

Provision towards compensation/rehabilitation of structure likely to be affected has been assessed. Sufficient provision is kept in the estimate to cover the cost of shifting of structures.

11.9 TRACTION & POWER SUPPLY

Provisions have been made to cover following subheads:

- OHE
- Receiving-cum-Traction Sub-stations including cables.
- ASS for elevated and at-grade stations.
- Service connection charges for Receiving Sub-stations.
- Scada augmentation.
- Miscellaneous items e.g. illumination, lifting T&P, etc.

The rates adopted for various items are based on costs of works being done for Delhi Metro Phase-II, duly updated to November 2015 price level.

11.10 ELECTRICAL SERVICES AT STATIONS

These are included in estimated costs of stations. Cost of escalators for elevated stations have not been included in station costs, and therefore, are provided under electrical estimates & shown separately.

11.11 SIGNALLING & TELECOMMUNICATION WORKS

The rates adopted are based on assessment done considering rates of similar sub-system on Delhi Metro, duly updated to November 2015 price level and TPWS works. These rates include escalation during manufacture & supply of equipment and their installation at site, but exclude CD and WT.

11.12 AUTOMATIC FARE COLLECTION

Adopted rates are based on assessment done considering rates of similar works in progress on Delhi Metro, duly updated to November 2015 price level. These rates exclude CD & WT, but include escalation during the period of equipment manufacture and their supply, including installation.

11.13 ROLLING STOCK

The estimated cost per coach at November 2015 Price level exclusive of taxes and duties has been taken as Rs. 10.60 crores per coach.

11.14 TAXES AND DUTIES

The component of Import Duty, Excise Duty and VAT is not included in the Capital cost estimated. The estimated taxes and duties work out to Rs. 1017 crores and Rs. 515 crores for corridor-1 and 2 respectively (Table 11.6 and 11.7)

**Table - 11.3 Details of Land cost (Corridor-1)
PCMC- Swargate Corridor**

A. Land Requirement for Alignment

S.NO.	PLOT NO.	LOCATION	DETAILS	AREA(m ²)	OWNERSHIP	RATE	COST (in Crores)
1	1RS 1	PCMC to SantTukaram Nagar	Open	136.3	Private	7000	0.10
2	1RS 2	PCMC to SantTukaram Nagar	Open	194.7	Government	7000	0.14
3	1RS 3	PCMC to SantTukaram Nagar	Open	309.9	Private	7000	0.22
4	1RS 4	PCMC to SantTukaram Nagar	Open	201.6	Private	7000	0.14
5	1RS 5	PCMC to SantTukaram Nagar	Commercial	85.6	Government	26000	0.22
6	1RS 6	PCMC to SantTukaram Nagar	Commercial	59.4	Government	26000	0.15
7	1RS 7	PCMC to SantTukaram Nagar	Open	17.8	Private	7000	0.01
8	1RS 8	PCMC to SantTukaram Nagar	Residential	25.3	Private	21500	0.05
9	1RS 9	PCMC to SantTukaram Nagar	Shop	23.7	Private	47500	0.11
10	1RS 10	PCMC to SantTukaram Nagar	Open	13.8	Private	7000	0.01
11	1RS 11	PCMC to SantTukaram Nagar	Residential	62	Private	21500	0.13
12	1RS 12	PCMC to SantTukaram Nagar	Open	95.7	Private	7000	0.07
13	1RS 13	PCMC to SantTukaram Nagar	Commercial	53.6	Private	26000	0.14
14	1RS 14	PCMC to SantTukaram Nagar	Commercial	11	Government	26000	0.03
15	1RS 15	PCMC to SantTukaram Nagar	Open	548.8	Private	7000	0.38
16	1RS 16	PCMC to SantTukaram Nagar	Commercial	27.6	Private	26000	0.07
17	1RS 17	PCMC to SantTukaram Nagar	Residential	87.3	Private	21500	0.19
18	1RS 18	PCMC to SantTukaram Nagar	Open	31	Private	7000	0.02
19	1RS 19	PCMC to SantTukaram Nagar	Commercial	167	Private	26000	0.43
20	1RS 20	PCMC to SantTukaram Nagar	Open	174.7	Private	7000	0.12
21	1RS 21	PCMC to SantTukaram Nagar	Commercial	161	Private	26000	0.42
22	1RS 22	PCMC to SantTukaram Nagar	Commercial	188.6	Private	26000	0.49
23	1RS 23	PCMC to SantTukaram Nagar	Commercial	179.6	Private	26000	0.47
24	1RS 24	PCMC to SantTukaram Nagar	Open	218.3	Private	7000	0.15
25	1RS 25	PCMC to SantTukaram Nagar	Commercial	12.8	Private	26000	0.03
26	1RS 26	PCMC to SantTukaram Nagar	Residential	160.1	Private	21500	0.34
27	1RS 27	PCMC to SantTukaram Nagar	Open	393.3	Private	7000	0.28

S.NO.	PLOT NO.	LOCATION	DETAILS	AREA(m ²)	OWNERSHIP	RATE	COST (in Crores)
28	1RS 28	PCMC to SantTukaram Nagar	Office	4.7	Government	26000	0.01
29	1RS 29	PCMC to SantTukaram Nagar	Office	19.9	Government	26000	0.05
30	1RS 30	PCMC to SantTukaram Nagar	Residential	37.4	Private	21500	0.08
31	1RS 31	PCMC to SantTukaram Nagar	Office	217.6	Government	26000	0.57
32	1RS 32	PCMC to SantTukaram Nagar	Commercial	1852.8	Private	26000	4.82
33	1RS 33	PCMC to SantTukaram Nagar	Office	11.1	Private	26000	0.03
34	1RS 34	PCMC to SantTukaram Nagar	Open	302.7	Private	7000	0.21
35	1RS 35	PCMC to SantTukaram Nagar	Office	4150	Government	26000	10.79
36	1RS 36	PCMC to SantTukaram Nagar	Open	152.4	Private	7000	0.11
37	1RS 37	PCMC to SantTukaram Nagar	Open	263.8	Private	7000	0.18
38	1RS 38	PCMC to SantTukaram Nagar	Residential	78.3	Private	215000	1.68
39	1RS 39	PCMC to SantTukaram Nagar	Open	16.7	Private	7000	0.01
40	1RS 40	SantTukaram Nagar to Bhosari (NashikPhata)	Open	221.6	Private	7000	0.16
41	1RS 41	SantTukaram Nagar to Bhosari (NashikPhata)	Office	8.8	Private	26000	0.02
42	1RS 42	SantTukaram Nagar to Bhosari (NashikPhata)	Commercial	4.3	Private	24800	0.01
43	1RS 43	SantTukaram Nagar to Bhosari (NashikPhata)	Open	718	Private	5500	0.39
44	1RS 44	SantTukaram Nagar to Bhosari (NashikPhata)	Open	254.1	Private	5500	0.14
45	1RS 45	SantTukaram Nagar to Bhosari (NashikPhata)	Commercial	33.2	Private	24800	0.08
46	1RS 46	SantTukaram Nagar to Bhosari (NashikPhata)	Open	63	Private	5500	0.03
47	1RS 47	SantTukaram Nagar to Bhosari (NashikPhata)	Open	1113.9	Private	5500	0.61
48	1RS 48	SantTukaram Nagar to Bhosari (NashikPhata)	Open	58.6	Private	5500	0.03
49	1RS 49	SantTukaram Nagar to Bhosari (NashikPhata)	Open	241.6	Private	5500	0.13
50	1RS 50	SantTukaram Nagar to Bhosari (NashikPhata)	Open	68.4	Private	5500	0.04
51	1RS 51	SantTukaram Nagar to Bhosari (NashikPhata)	Open	120.9	Private	5500	0.07
52	1RS 52	SantTukaram Nagar to Bhosari (NashikPhata)	Commercial	43.6	Government	24800	0.11
53	1RS 53	SantTukaram Nagar to Bhosari (NashikPhata)	Open	240	Private	5500	0.13
54	1RS 54	SantTukaram Nagar to	Commercial	24.8	Private	24800	0.06

S.NO.	PLOT NO.	LOCATION	DETAILS	AREA(m ²)	OWNERSHIP	RATE	COST (in Crores)
		Bhosari(NashikPhata)					
55	1RS 55	SantTukaram Nagar to Bhosari (NashikPhata)	Open	17	Private	5500	0.01
56	1RS 56	SantTukaram Nagar to Bhosari (NashikPhata)	Commercial	71.8	Private	24800	0.18
57	1RS 57	SantTukaram Nagar to Bhosari (NashikPhata)	Shop	24.8	Private	40200	0.10
58	1RS 58	Bhosari(NashikPhata)to Kasarwadi	Open	373.5	Private	5500	0.21
59	1RS 59	Bhosari(NashikPhata)to Kasarwadi	Residential	24	Private	18200	0.04
60	1RS 60	Bhosari(NashikPhata) to Kasarwadi	Residential	12.5	Private	18200	0.02
61	1RS 61	Bhosari(NashikPhata) to Kasarwadi	Shop	12.6	Private	40200	0.05
62	1RS 62	Bhosari(NashikPhata) to Kasarwadi	Residential	58	Private	18200	0.11
63	1RS 63	Bhosari(NashikPhata) to Kasarwadi	Residential	10.1	Private	18200	0.02
64	1RS 64	Bhosari(NashikPhata) to Kasarwadi	Residential	1392.4	Private	18200	2.53
65	1RS 65	Bhosari(NashikPhata) to Kasarwadi	Residential	28.1	Private	18200	0.05
66	1RS 66	Bhosari(NashikPhata) to Kasarwadi	Residential	35.2	Private	18200	0.06
67	1RS 67	Bhosari(NashikPhata) to Kasarwadi	Residential	14.9	Private	18200	0.03
68	1RS 68	Bhosari(NashikPhata) to Kasarwadi	Residential	15.6	Private	18200	0.03
69	1RS 69	Bhosari(NashikPhata) to Kasarwadi	Shop	30.6	Private	40200	0.12
70	1RS 70	Bhosari(NashikPhata) to Kasarwadi	Shop	110.2	Private	40200	0.44
71	1RS 71	Bhosari(NashikPhata) to Kasarwadi	Residential	37.6	Private	18200	0.07
72	1RS 72	Bhosari(NashikPhata) to Kasarwadi	Residential	66.5	Private	18200	0.12
73	1RS 73	Bhosari(NashikPhata) to Kasarwadi	Residential	23.2	Private	18200	0.04
74	1RS 74	Bhosari(NashikPhata) to Kasarwadi	Residential	111.1	Private	18200	0.20
75	1RS 75	Bhosari(NashikPhata) to Kasarwadi	Residential	1.4	Private	18200	0.00
76	1RS 76	Bhosari(NashikPhata) to Kasarwadi	Residential	30.3	Private	18200	0.06
77	1RS 77	Bhosari(NashikPhata) to Kasarwadi	Residential	64.1	Private	18200	0.12
78	1RS 78	Bhosari(NashikPhata) to Kasarwadi	Office	1249.2	Private	24800	3.10

S.NO.	PLOT NO.	LOCATION	DETAILS	AREA(m ²)	OWNERSHIP	RATE	COST (in Crores)
79	1RS 79	Bhosari(NashikPhata) to Kasarwadi	Residential	0.9	Private	18200	0.00
80	1RS 80	Bhosari(NashikPhata) to Kasarwadi	Commercial	87.7	Private	24800	0.22
81	1RS 81	Bhosari(NashikPhata) to Kasarwadi	Office	250.5	Private	24800	0.62
82	1RS 82	Kasarwadi to Fugewadi	Office	121.9	Private	23600	0.29
83	1RS 83	Kasarwadi to Fugewadi	Shops	15.2	Private	42200	0.06
84	1RS 84	Kasarwadi to Fugewadi	Office	321.9	Private	23600	0.76
85	1RS 85	Kasarwadi to Fugewadi	Commercial	60.1	Private	23600	0.14
86	1RS 86	Kasarwadi to Fugewadi	Office	766.8	Private	23600	1.81
87	1RS 87	Kasarwadi to Fugewadi	Office	76.8	Private	23600	0.18
88	1RS 88	Kasarwadi to Fugewadi	Commercial	47.3	Private	23600	0.11
89	1RS 89	Kasarwadi to Fugewadi	Commercial	78.5	Private	23600	0.19
90	1RS 90	Kasarwadi to Fugewadi	Residential	52.6	Private	15000	0.08
91	1RS 91	Kasarwadi to Fugewadi	Residential	51.9	Private	15000	0.08
92	1RS 92	Kasarwadi to Fugewadi	Residential	25.5	Private	15000	0.04
93	1RS 93	Kasarwadi to Fugewadi	Residential	76.9	Private	15000	0.12
94	1RS 94	Kasarwadi to Fugewadi	Commercial	26.8	Private	15000	0.04
95	1RS 95	Kasarwadi to Fugewadi	Residential	223	Private	15000	0.33
96	1RS 96	Kasarwadi to Fugewadi	Commercial	32.4	Private	23600	0.08
97	1RS 97	Kasarwadi to Fugewadi	Residential	18.7	Private	15000	0.03
98	1RS 98	Kasarwadi to Fugewadi	Commercial	37.3	Private	23600	0.09
99	1RS 99	Kasarwadi to Fugewadi	Residential	13.7	Private	14500	0.02
100	1RS 100	Kasarwadi to Fugewadi	Commercial	120	Government	22400	0.27
101	1RS 101	Fugewadi to Dapodi	Office	1636	Private	22400	3.66
102	1RS 102	Fugewadi to Dapodi	Office	657.3	Private	22400	1.47
103	1RS 103	Fugewadi to Dapodi	Office	16366.3	Private	22400	36.66
104	1RS 104	Dapodi to Bopodi	Office	10179.2	Private	37100	37.76
105	1RS 105	Dapodi to Bopodi	Office	1527.8	Private	37100	5.67
106	1RS 106	Bopodi to Khadki	Office	47.7	Private	36000	0.17
107	1RS 107	Bopodi to Khadki	Residential	9.6	Private	29000	0.03

S.NO.	PLOT NO.	LOCATION	DETAILS	AREA(m ²)	OWNERSHIP	RATE	COST (in Crores)
108	1RS 108	Bopodi to Khadki	Residential	4.9	Private	29000	0.01
109	1RS 109	Bopodi to Khadki	Office	6.9	Private	36000	0.02
110	1RS 110	Bopodi to Khadki	Residential	6.9	Private	29000	0.02
111	1RS 111	Bopodi to Khadki	Office	211.4	Private	36000	0.76
112	1RS 112	Khadki to RangeHill	Residential	43.4	Private	20000	0.09
113	1RS 113	Khadki to Range Hill	Residential	11.9	Government	20000	0.02
114	1RS 114	Khadki to Range Hill	Residential	40.3	Government	20000	0.08
115	1RS 115	Khadki to Range Hill	Shops	28.1	Private	33000	0.09
116	1RS 116	Khadki to Range Hill	Office	69.3	Private	27000	0.19
117	1RS 117	Khadki to Range Hill	Residential	18.1	Private	20000	0.04
118	1RS 118	Khadki to Range Hill	Residential	40.2	Government	20000	0.08
119	1RS 119	Khadki to Range Hill	Office	37.5	Private	27000	0.10
120	1RS 120	Khadki to Range Hill	Office	186.4	Private	27000	0.50
121	1RS 121	Khadki to Range Hill	Office	10554.5	Private	27000	28.50
122	1RS 122	Khadki to Range Hill	Office	465.2	Private	27000	1.26
123	1RS 123	Khadki to Range Hill	Office	271.6	Private	27000	0.73
124	1RS 124	Khadki to Range Hill	Office	2581.3	Private	27000	6.97
125	1RS 125	Khadki to Range Hill	Office	3523	Private	27000	9.51
126	1RS 126	Khadki to Range Hill	Office	1891.4	Private	27000	5.11
127	1RS 127	Khadki to Range Hill	Office	219.6	Private	36500	0.80
128	1RS 128	Khadki to Range Hill	Office	297.6	Private	36500	1.09
129	1RS 129	Range Hill to Shivaji Nagar	Office	1931.6	Private	36500	7.05
130	1RS 130	Range Hill to Shivaji Nagar	Office	7092	Private	36500	25.89
131	1RS 131	Range Hill to Shivaji Nagar	Office	1013.9	Private	38000	3.85
	TOTAL			81254.7			216.95

B. Land Required For Stations

S.NO.	PLOT NO.	AREA(m ²)	RATE	COST in Crores	TYPE OF PROPERTY	OWNERSHIP
1	PCMC1	2483.97	7000	1.74	Open	Government
2	PCMC2	468.00	7000	0.33	Open	Government
3	STR1	2519.99	7000	1.76	Open	Government
4	STR2	468.00	7000	0.33	Open	Government
5	BR1	2520.85	40200	10.13	Hotel+Shop Line	Government
6	BR2	468.00	18200	0.85	Residential	Government
7	KR1	2519.67	24800	6.25	Commercial+Shop	Government
8	KR2	468.00	23600	1.10	Open	Government
9	FW1	2528.02	22400	5.66	Open	Government
10	FW2	468.00	22400	1.05	Open	Government
11	DP1	2527.05	22400	5.66	Open	Government
12	DP2	468.00	22400	1.05	Commercial+Shop	Government
13	BP1	420.00	36000	1.51	House Line	Government
14	BP2	420.00	36000	1.51	House Line	Government
15	BP3	468.00	36000	1.68	Open	Private
16	KH1	420.00	20000	0.84	Open	Government
17	KH2	420.00	20000	0.84	Open	Government
18	KH3	468.00	20000	0.94	Open	Private
19	HR1	2626.83	36500	9.59	Open	Government
20	HR2	468.00	36500	1.71	Open	Private
21	SN1	364.90	38000	1.39	Open	Government
22	SN2	1095.37	38000	4.16	Open	Government
23	SN3	900.00	38000	3.42	Open	Government
24	SN4	148.60	38000	0.56	Open	Government
25	SN5	148.20	38000	0.56	Commercial	Government
26	SN6	68.90	38000	0.26	Open	Government
27	SN7	835.90	38000	3.18	Open+commercial	Private

S.NO.	PLOT NO.	AREA(m ²)	RATE	COST in Crores	TYPE OF PROPERTY	OWNERSHIP
28	SN8	582.60	38000	2.21	Open	Government
29	ASI1	922.51	38000	3.51	Open	Government
30	ASI2	2830.70	38000	10.76	Open	Government
31	PMC1	3150.70	38000	11.97	Open	Government
32	PMC2	3946.00	38000	14.99	Open	Government
33	PMC3	61.90	38000	0.24	Commercial	Government
34	BH1	2376.20	38000	9.03	Open	Government
35	BH2	85.59	38000	0.33	Open	Government
36	MN1	3661.90	38000	13.92	Open	Government
37	MN2	32.70	38000	0.12	Commercial	Private
38	SW1	1008.60	38000	3.83	Open	Private
39	SW2	141.90	38000	0.54	Open	Private
40	SW3	3074.20	38000	11.68	Open	Private
41	SW4	457.70	38000	1.74	Open	Private
42	SW5	233.40	38000	0.89	Open	Private
Total		49746.86		153.83		

C. Land Requirement for Depot

S.No.	PLOT No.	DETAILS	AREA(m ²)	OWNERSHIP	RATE	COST (crores)
1	1DP1	Open	115143.354	Government	7092	81.66

D. Land Requirement for TSS

S.No.	AREA (m ²)	OWNERSHIP	RATE	COST in crores
1	12000	Government	11120	13.344

E. Land Requirement for Construction Depot

S.NO.	AREA(m ²)	OWNERSHIP	RATE	COST (incrore)
1	40000	Private	1260	5.04
2	40000	Private	6570	26.28
3	10000	Private	6840	6.84
	90000			38.16

**Table- 11.4 - Details of Land Cost (Corridor -2)
Vanaz - Ramvadi Corridor**

A. Land Requirement for Alignment

S.NO.	PLOT NO.	LOCATION	DETAILS	AREA (m ²)	OWNERSHIP	RATE	COST (in Crores)
1	2RS 1	Anand Nagar to Ideal Colony	Open	44.4	Private	40000	0.178
2	2RS 2	Anand Nagar to Ideal Colony	Open	80.9	Government	70000	0.566
3	2RS 3	Anand Nagar to Ideal Colony	Open	8.5	Private	37000	0.031
4	2RS 4	Ideal Colony to Nal Stop	Open	50.4	Private	11000	0.055
5	2RS 5	Ideal Colony to Nal Stop	Commercial	10.1	Government	11000	0.011
6	2RS 6	Ideal Colony to Nal Stop	Commercial	96.1	Government	82000	0.788
7	2RS 7	Ideal Colony to Nal Stop	Open	39.7	Private	82000	0.326
8	2RS 8	Ideal Colony to Nal Stop	Residential	4.7	Private	54000	0.025
9	2RS 9	Ideal Colony to Nal Stop	Shop	86.2	Private	54000	0.465
10	2RS 10	Ideal Colony to Nal Stop	Open	18.7	Private	54000	0.101
11	2RS 11	Ideal Colony to Nal Stop	Residential	17.8	Private	82000	0.146
12	2RS 12	Ideal Colony to Nal Stop	Open	3.8	Private	82000	0.031
13	2RS 13	Garware College to Deccan*	Commercial	2660.1	Private	41000	10.906
14	2RS 14	ASI to Civil Court*	Open	2600.1	Private	14250	3.705
15	2RS 15	ASI to Civil Court*	Commercial	156.2	Private	14250	0.223
16	2RS 16	ASI to Civil Court*	Open	681.1	Private	14250	0.971
17	2RS 17	Civil Court to MangalwarPeth	Commercial	249.2	Private	14250	0.355
18	2RS 18	Civil Court to MangalwarPeth	Commercial	383.3	Private	14250	0.546
19	2RS 19	Civil Court to MangalwarPeth	Commercial	2961.5	Private	13000	3.850
20	2RS 20	Civil Court to MangalwarPeth	Open	53.1	Private	26850	0.143
21	2RS 21	Civil Court to MangalwarPeth	Commercial	2908.4	Private	26850	7.809
22	2RS 22	Civil Court to MangalwarPeth	Residential	1344.8	Private	42000	5.648
23	2RS 23	MangalwarPeth to Sasson	Open	876.3	Private	30500	2.673
24	2RS 24	MangalwarPeth to Sasson	Office	18.6	Government	21500	0.040

S.NO.	PLOT NO.	LOCATION	DETAILS	AREA (m ²)	OWNERSHIP	RATE	COST (in Crores)
25	2RS 25	Sasson to Pune R. Station	Office	78.6	Government	21500	0.169
26	2RS 26	Sasson to Pune R. Station	Residential	114.2	Private	21500	0.246
27	2RS 27	Pune R. Station to Ruby Clinic	Office	768.3	Government	21500	1.652
28	2RS 28	Pune R. Station to Ruby Clinic	Commercial	250	Private	24500	0.613
29	2RS 29	Pune R. Station to Ruby Clinic	Office	40.1	Private	41500	0.166
30	2RS 30	Pune R. Station to Ruby Clinic	Open	110.7	Private	41500	0.459
31	2RS 31	Ruby Clinic to Bund Garden	Office	71.9	Government	41500	0.298
32	2RS 32	Bund Garden to Yerawada	Open	2656.7	Private	16000	4.251
33	2RS 33	Bund Garden to Yerawada	Open	71.6	Private	42000	0.301
34	2RS 34	Bund Garden to Yerawada	Residential	43.8	Private	56000	0.245
35	2RS 35	Bund Garden to Yerawada	Residential	23.1	Private	42000	0.097
36	2RS 36	Bund Garden to Yerawada	Shops	8.9	Private	42000	0.037
37	2RS 37	Bund Garden to Yerawada	Residential	2609.1	Private	16000	4.175
38	2RS 38	Yerawada to Kalyani Nagar	Open	303.8	Private	16000	0.486
39	2RS 39	Yerawada to Kalyani Nagar	Open	20.9	Private	16000	0.033
40	2RS 40	Yerawada to Kalyani Nagar	Shops	35.6	Private	45000	0.160
41	2RS 41	Yerawada to Kalyani Nagar	Shops	31.4	Private	60000	0.188
42	2RS 42	Yerawada to Kalyani Nagar	Office	4402.6	Government	73000	32.139
43	2RS 43	Yerawada to Kalyani Nagar	Office	12.7	Government	45000	0.057
44	2RS 44	Yerawada to Kalyani Nagar	Shops	14.1	Private	45000	0.063
45	2RS 45	Yerawada to Kalyani Nagar	Shops	33.7	Private	51000	0.172
	TOTAL			27055.8			85.60

*Between Garware college & City civil court 3 stations proposed (Deccan, Sambhajipark & PMC)

B. Land Requirement for Station and Traffic Integration

S.NO.	PLOT NO.	DETAILS	AREA (m ²)	OWNERSHIP	RATE	COST in crores
1	VN1	Open	468	Private	40000	1.872
2	VN2	Open	420	Private	40000	1.680
3	VN3	Open	420	Private	40000	1.680
4	AN1	Open	468	Private	40000	1.872
5	AN2	Residential	420	Private	40000	1.680
6	AN3	Residential	420	Private	40000	1.680
7	1C1	Open	468	Private	37000	1.732
8	1C2	Commercial	420	Private	37000	1.554
9	1C3	Commercial	420	Private	37000	1.554
10	NS1	Open	468	Private	41000	1.919
11	NS2	Commercial	420	Private	41000	1.722
12	NS3	Commercial	420	Private	41000	1.722
13	GC1	Open	468	Government	41000	1.919
14	GC2	Residential	420	Private	41000	1.722
15	GC3	Residential	420	Private	41000	1.722
16	DC1	Open	468	Private	77000	3.604
17	DC2	Open	420	Private	77000	3.234
18	DC3	Residential	420	Private	77000	3.234
19	ASI'1	Open	468	Private	77000	3.604
20	ASI'2	Commercial	420	Private	77000	3.234
21	ASI'3	Commercial	420	Private	77000	3.234
22	CC1	Open	468	Private	14250	0.667
23	CC2	Residential	420	Private	14250	0.599
24	CC3	Residential	420	Private	14250	0.599
25	MP1	Open	468	Private	42000	1.966
26	MP2	Open	420	Private	42000	1.764
27	MP3	Commercial	420	Private	42000	1.764
28	SN1	Open	468	Private	21500	1.006

S.NO.	PLOT NO.	DETAILS	AREA (m ²)	OWNERSHIP	RATE	COST in crores
29	SN2	Commercial	420	Government	21500	0.903
30	SN3	Commercial	420	Government	21500	0.903
31	PRS1	Commercial	468	Private	21500	1.006
32	PRS2	Commercial	420	Private	21500	0.903
33	PRS3	Commercial	420	Private	21500	0.903
34	RC1	Open	468	Private	41500	1.942
35	RC2	Open	420	Government	41500	1.743
36	RC3	Commercial	420	Private	41500	1.743
37	BG1	Shop	468	Private	16000	0.749
38	BG2	Commercial	420	Private	16000	0.672
39	BG3	Commercial	420	Private	16000	0.672
40	YD1	Commercial	468	Private	16000	0.749
41	YD2	Commercial	2520.327	Private	16000	4.032
42	KN1	Residential	468	Private	51000	2.387
43	KN2	Residential	2514.219	Private	51000	12.823
44	RV1	Open	468	Govt.	51000	2.387
45	RV2	Open	420	Govt.	51000	2.142
46	RV3	Open	420	Govt.	51000	2.142
	Total		24282.546			93.337

C. Land Requirement for Depot

S.NO.	PLOT NO.	DETAILS	AREA(m ²)	OWNERSHIP	RATE	COST in crores
1	2DP1	Open	121115.657	Government	7092	85.90

D. Land Requirement for TSS

S.No.	AREA (m ²)	OWNERSHIP	RATE	COST(in crores)
1	12000	Government	11120	13.344

E. Land Requirement for Construction Depot

S. No.	AREA(m ²)	OWNERSHIP	RATE	COST(in crores)
1	5000	Private	9180	4.59

Table 11.5 – Details of Land required for Property Development

S. No	Location	Land Area (Sqm)	Ownership
1	Kharadi	6812	Private
2	Kharadi	7114	Private
3	Wadgon Sheri	17237	Private
4	Kondhawakh	5668	Private
5	Kondhawabk	6730	Private
6	Baner	5143	Private
7	Balewadi	5731	Private
8	Swargate	10000	Irrigation Department
	Total	64435	

Description	Total cost without Taxes & duties (Cr.)	Taxes and duties			Total taxes & duties (Cr.)
		custom duty (Cr.)	excise duty (Cr.)	VAT	
Customs duty =	25.22	%			
Excise duty =	14.47	%			
VAT =	12.5	%			
Alignment & Formation					
Underground	499.60	37.80	35.42	35.03	108.25
Elevated, at grade & entry to Depot	401.61		40.68	40.23	80.90
Station Buildings					
a) Underground station-civil works	900.00	68.09	63.81	63.10	195.01
b) Underground station-EM works	360.00	45.40	22.14	21.89	89.43
a) Elevated station - civil works	239.80		24.29	24.02	48.31
b) Elevated station-EM works	106.29	5.36	10.46	10.34	26.16
e) Metro bhawan& OCC bldg-civil works	56.25		5.70	5.63	11.33
f) Metro bhawan& OCC bldg-EM works	18.75	0.95	1.84	1.82	4.62
Depot					
Civil works	100.00	7.57	7.09	7.01	21.67
EM works	50.00	2.52	4.92	4.86	12.31
P-Way	149.85	30.23	3.69	3.65	37.56
Traction & power supply					
Traction and power supply	207.23	20.91	15.29	15.12	51.32
a) Lifts	0.00	0.00	0.00	0.00	0.00
b) Escalators	0.00	0.00			0.00
S and T Works					
S & T	276.63	55.81	8.01	7.92	71.73
AFC	81.12	15.34	2.93	2.90	21.18
R & R hutments	0.00			0.00	0.00
Misc.					
Civil works	89.36		9.05	8.95	18.00
EM works	29.79		3.66	3.62	7.29
Rolling stock	805.62	178.80	9.09	8.99	196.88
Security					
Civil works	12.00		1.22	1.20	2.42
EM works	8.00		1.16	1.14	2.30
Total	4391.90	468.78	270.45	267.44	1006.67
Total taxes & Duties					1007

Customs duty =	25.22	%			
Excise duty =	14.47	%			
VAT =	12.5	%			
Description	Total cost without Taxes & duties (Cr.)	Taxes and duties			Total taxes & duties (Cr.)
		custom duty (Cr.)	excise duty (Cr.)	VAT	
Alignment & Formation					
Underground	0.00	0.00	0.00	0.00	0.00
Elevated, at grade & entry to Depot	503.77		51.03	50.46	101.48
Station Buildings					
a) Underground station-civil works	0.00	0.00	0.00	0.00	0.00
b) Underground station-EM works	0.00	0.00	0.00	0.00	0.00
a) Elevated station - civil works	421.83		42.73	42.25	84.98
b) Elevated station-EM works	188.93	9.53	18.59	18.38	46.50
e) Metro bhawan& OCC bldg-civil works	0.00		0.00	0.00	0.00
f) Metro bhawan& OCC bldg-EM works	0.00	0.00	0.00	0.00	0.00
Depot					
Civil works	100.00	7.57	7.09	7.01	21.67
EM works	50.00	2.52	4.92	4.86	12.31
P-Way	134.79	27.20	3.32	3.28	33.79
Traction & power supply					
Traction and power supply	161.99	16.34	11.95	11.82	40.12
a) Lifts	0.00	0.00	0.00	0.00	0.00
b) Escalators	0.00	0.00			0.00
S and T Works					
S & T	246.37	49.71	7.13	7.05	63.89
AFC	81.12	15.34	2.93	2.90	21.18
R & R hutments	0.00			0.00	0.00
Misc.					
Civil works	41.67		4.22	4.17	8.40
EM works	13.89		1.71	1.69	3.40
Rolling stock	296.81	65.87	3.35	3.31	72.53
Security					
Civil works	12.00		1.22	1.20	2.42
EM works	8.00		1.16	1.14	2.30
Total	2261.18	194.08	161.34	159.54	514.96
Total taxes & Duties					515

Chapter -12

Financing Options, Fare Structure and Financial Viability



- 12.1 Introduction
- 12.2 Cost
- 12.3 Revenues
- 12.4 Financial Internal Rate of Return (FIRR)
- 12.5 Financing Options
- 12.6 Recommendations



CHAPTER - 12

FINANCING OPTIONS, FARE STRUCTURE AND FINANCIAL VIABILITY

12.1 INTRODUCTION

The Pune Metro consisting of two corridors has been proposed to be constructed with an estimated cost of Rs 9221.00 Crore with Central Taxes and land cost excluding State Taxes. The corridor-wise length estimated cost at November-2015 price level without central taxes and with central taxes is placed in **Table 12.1** as under:

Table - 12.1 Cost Details

(Rs. in Crore)

Corridor No	Name of Corridor	Distance (KMs)	Estimated Cost without Central taxes at Nov-2015 Price Level	Estimated Cost with Central taxes at Nov-2015 Price Level
I	PCMC-SEWARGATE	16.589	5333.00	6072.00
II	VANAZ-RAMVADI	14.665	2794.00	3149.00
Total		31.254	8127.00	9221.00

The estimated cost at Nov-2015 price level includes Rs. 583 Crore and Rs.349 Crore as land cost including R&R cost respectively for Corridor I and II. The estimated cost at Nov-2015 price level also includes an amount of Rs. 40.00 Crore as one-time charges of security personal towards cost of weapons, barricades, and hand held and door detector machine etc. However, the recurring cost of Rs. 1.11 Crore per station per annum at Nov-2015 price level towards operation cost of CISF has been taken in to account in FIRR calculation.

12.2 COSTS

12.2.1 Investment Cost

For the purpose of calculating the Financial Internal Rate of Return (FIRR), the completion cost with central taxes has been taken with an escalation factor @5% per annum. The taxes and duties consist of Custom Duty (CD), Excise Duty (ED) and State Value Added Tax (VAT). Pune Metro project is eligible for availing concessional project import duty under chapter 98.01 of the Custom Tariff Act. The effective CD works out to 23.4155% (Basic CD (5%), Countervail Duty (CVD) + Additional Custom Duty (ACD)) on the imported portions and ED @ 12.50% and VAT @ 12.50% on indigenously manufactured items, which have been considered for working out the estimated taxes and duties. Service Tax on "Works Contract Services" on new construction pertaining to Metro and Mono Rail Projects is exempted from the Service Tax and therefore the same has been considered as Nil in the estimated cost. It has been assumed that Maharashtra State Government will exempt the local taxes or reimburse the same (State VAT,

etc) and provide the land including R&R cost of Rs. 932.00 crore at Nov-2015 price level either free of cost or shall provide Interest Free Subordinate Debt.

It is assumed that the construction work for both the corridors will start in April-2016 and Corridor-II is expected to be completed by 31.03.2020 & Corridor-I by 31.03.2021. The Revenue Opening Date (ROD) has been assumed accordingly. The total completion costs duly escalated and shown in the table 12.2 have been taken as the initial investment. The year-wise cash outgo is shown in **Table 12.2** as below.

Table 12.2 - Year -wise Investment

(Rs. in Crore)

Financial Year	Cost at Nov 2015 Price Level			Completion Cost		
	Corridor-I	Corridor-II	Total	Corridor-I	Corridor-II	Total
2016-17	305.00	200.00	505.00	307.00	202.00	509.00
2017-18	1017.00	537.00	1554.00	1076.00	567.00	1643.00
2018-19	1456.00	816.00	2272.00	1614.00	904.00	2518.00
2019-20	1372.00	700.00	2072.00	1621.00	827.00	2448.00
2020-21	1098.00	616.00	1714.00	1362.00	764.00	2126.00
2021-22	549.00	280.00	829.00	715.00	365.00	1080.00
2022-23	275.00	0.00	275.00	376.00	0.00	376.00
Total	6072.00	3149.00	9221.00	7071.00	3629.00	10700.00

Although the construction is expected to get over by March 2020 and March 2021, the cash flow spill over up to March 2023 is necessary on account of payment normally required to be made to the various contractors up to that period necessitated by contractual clauses.

The land cost is divided into three initial years during which it is expected that the land acquisition work would be over and related payments would have to be released. Therefore, no escalation has been considered on it.

12.2.2 Additional Investment

Total investment provided in the FIRR calculation towards requirement of additional rolling stock to take care of incremental traffic, duly escalated @5% PA is placed in **Table 11.3** as under: -

Table 12.3 - Additional Investment towards Rolling Stock

(Rs. in Crore)

Year	No. of Cars	Amount with Taxes
2023-24	24	464.00
2033-34	8	252.00

12.2.3 Operation & Maintenance (O&M) Costs

The Operation & Maintenance costs can be divided into three major parts: -

- (i) Staff costs
- (ii) Maintenance cost which include expenditure towards upkeep and maintenance of the system and consumables
- (iii) Energy costs

The staffs are assumed to be provided @ 35 persons per kilometre. The escalation factor used for staff costs is 9% per annum to provide for both escalation and growth in salaries.

The cost of other expenses is based on the actual O & M unit cost for the Delhi Metro Phase-II project. The applicable rate of electricity in Pune is Rs. 7.68 per unit and the same has been used for all calculations. The O&M cost (excluding staff cost) has been obtained by providing an escalation of 6% per annum. The O&M cost which has been calculated on life cycle cost basis is tabulated in Table 11.4 as below:-

Table 12.4 - Operation and Maintenance Costs

(Rs. in Crore)

Year			Staff	Maintenance Expenses	Energy	Security	Total
2020	-	2021	31.55	25.08	19.04	15.36	91.03
2021	-	2022	70.07	59.01	87.82	34.91	251.82
2022	-	2023	76.38	61.97	92.22	38.05	268.61
2023	-	2024	83.25	65.06	109.90	41.48	299.70
2024	-	2025	90.74	68.32	115.40	45.21	319.67
2025	-	2026	98.91	71.73	121.17	49.28	341.09
2026	-	2027	107.81	75.32	127.23	53.72	364.07
2027	-	2028	117.51	79.09	133.59	58.55	388.74
2028	-	2029	128.09	83.04	140.27	63.82	415.22
2029	-	2030	139.62	87.19	147.28	69.57	443.65
2030	-	2031	152.18	91.55	154.64	75.83	474.20
2031	-	2032	165.88	96.13	162.38	82.65	507.04
2032	-	2033	180.81	100.93	170.49	90.09	542.33
2033	-	2034	197.08	105.98	236.05	98.20	637.31
2034	-	2035	214.82	111.28	247.85	107.04	680.99
2035	-	2036	234.15	116.84	260.25	116.67	727.91
2036	-	2037	255.23	122.69	273.26	127.17	778.34
2037	-	2038	278.20	128.82	286.92	138.61	832.56
2038	-	2039	303.24	135.26	301.27	151.09	890.86
2039	-	2040	330.53	142.03	316.33	164.69	953.57
2040	-	2041	360.27	149.13	332.15	179.51	1021.06
2041	-	2042	392.70	156.58	348.76	195.67	1093.70
2042	-	2043	428.04	164.41	366.19	213.27	1171.92
2043	-	2044	466.56	172.63	384.50	232.47	1256.17
2044	-	2045	508.56	181.26	403.73	253.39	1346.94
2045	-	2046	554.33	190.33	423.92	276.20	1444.77

12.2.4 Depreciation

Although depreciation does not enter the FIRR calculation (not being a cash outflow) unless a specific depreciation reserve fund has been provided, in the present calculation, depreciation calculations are placed for purpose of record.

12.2.5 Replacement Cost

The replacement costs are provided for meeting the cost on account of replacement of equipment due to wear and tear. With the nature of equipment proposed to be provided, it is expected that only 50% of the Signalling and Telecom and 25% of electrical works would require replacement after 20 years. Further, 50% of the Signalling and Telecom and 25% of electrical works would require replacement after 30 years. These costs have been provided duly escalated @ 7.50% per annum.

12.3 REVENUES

The Revenue of Pune metro mainly consists of fare box collection and other incomes from property development, advertisement, parking etc.

In addition it is proposed (i) to enhance the development charge by 100% on properties and (ii) to levy a surcharge of 1% on stamp duty and registration fees on property transaction in PMC and PCMC areas after commissioning of proposed Metro Project.

12.3.1 Fare box

The Fare box collection is the product of projected ridership per day and applicable fare structure based on assumed trip distribution at different distance zones.

12.3.2 Traffic

a. The year-wise projected ridership figures are as indicated in **Table 12.5** as below: -

Table 12.5 - Projected Ridership

Year	Corridor-I Trips Per Day (lakhs)	Corridor-II Trips Per Day (lakhs)	Total Trips Per Day (lakhs)
2020-21	0.00	2.04	2.04
2021-22	3.97	2.12	6.09
2031-32	4.44	2.90	7.34

b. The growth rate for traffic is assumed at 1.90% Per Annum upto 2031-32 and 1% thereafter.

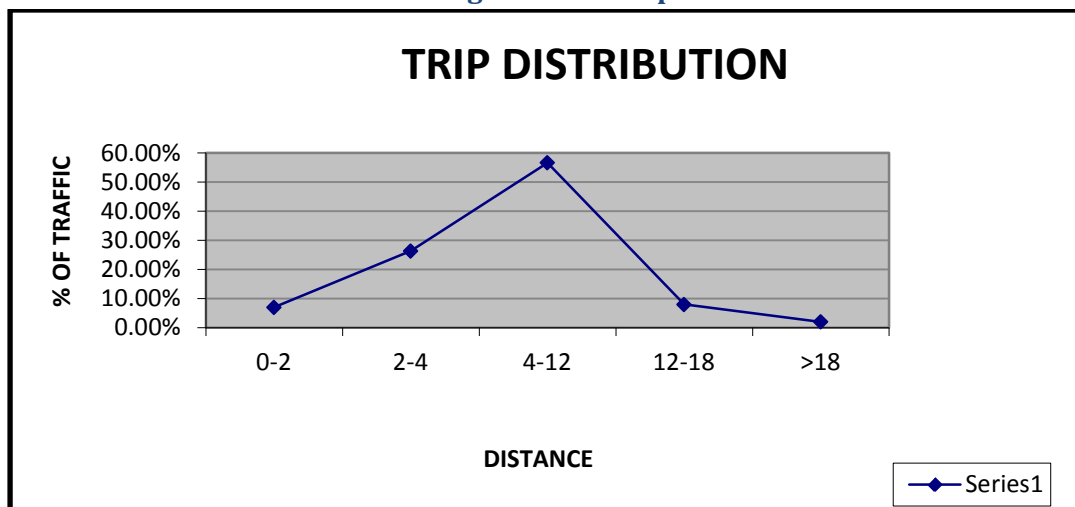
12.3.3 Trip Distribution

The trip distribution has been worked out by considering average lead of 6.95 KM, which is placed in **Table 12.6** below: -

Table 12.6 - Trip Distribution

Distance in kms.	Percent distribution
0-2	7.00%
2-4	26.35%
4-12	56.65%
12-18	8.00%
>18	2.00%
Total	100.00%

The graphic presentation of the same is placed below in **Figure-12.1**.

Figure 12.1 - Trip Distribution


12.3.4 Fare Structure

The Delhi Metro Fares structure was fixed by a fare fixation committee in 2009 by taking the data upto 31.03.2010 the same have been escalated @15% once in every two years and rounded to nearest Rs.10/- to arrive at the initial fare structure for Pune Metro so that tendering change at the stations may not pose problem, which is placed in **Table 12.7**.

Table 12.7 – Fare Structure in 2020-21

Distance in Kms	DMRC Fare as Revised in 2009	Pune Metro Fare (Rs.) in 2020-21
0-2	8	10
2-4		20
4-12	10	30
12-18	12	40
>18	15	50

12.3.5 Other sources of revenues

Other revenues from Property Development and advertisement have been estimated at 10% of the fare box revenues during operations. Apart from development of property on metro stations and depot it is possible to raise resources through leasing of parking rights at stations, advertisement on trains and tickets, advertisements within stations and parking lots, advertisements on viaducts, columns and other metro structures, co-branding rights to corporate, film shootings and special events on metro premises.

SPV/BOT operator will engage a developer/Concessionaire for generating rental income. It is assumed that about 10.4435 Hectare. i.e., 41,77,400 square feet area will be available for property development with a FAR of 4. The developer will bring equity to the extent of Rs.184.00 crore and the balance amount towards construction shall be raised by SPV as 12% Market Debt. The estimated development cost will be Rs.922.00 crore. It is assumed that the rental revenue @ Rs. 40 per sq. ft. will accrue to the developer from the FY 2021-22 which has been escalated @5% every year. Out of the estimated rental income, apart from meeting maintenance expenditure, the developer will repay the loan and interest. After meeting these obligations and retaining 14% return on his equity with an escalation @5% every year, the residual rental earnings will accrue to SPV, which has been taken into account in the FIRR calculations. The details of PD income accrue to SPV is tabulated as under; -

Estimated generation of Rental Income from PD

Rs. in Crore

Year			Constr uction cost	Rental Income	Maint enanc e Expen diture	Loan	IDC	Loan repaym ent	Bal Loan Amount	Interest on Loan @12%	Return @14% to the developer	Residual rental income to SPV
2016	-	2017	167			121	7		128		-46	
2017	-	2018	175			129	16		273		-46	
2018	-	2019	184			138	19		430		-46	
2019	-	2020	193			147	21		598		-46	
2020	-	2021	203			203	26		827		0	
2021	-	2022		51	5			83	744	99	26	-162
2022	-	2023		71	7			83	661	89	27	-135
2023	-	2024		99	10			83	578	79	28	-101
2024	-	2025		156	16			83	495	69	29	-41
2025	-	2026		327	33			83	412	59	30	122
2026	-	2027		343	34			83	329	49	32	145
2027	-	2028		360	36			83	246	39	34	168
2028	-	2029		378	38			83	163	30	36	191
2029	-	2030		397	40			83	80	20	38	216
2030	-	2031		417	42			80	0	10	40	245
2031	-	2032		438	44						42	352
2032	-	2033		460	46						44	370
2033	-	2034		483	48						46	389
2034	-	2035		507	51						48	408
2035	-	2036		532	53						50	429
2036	-	2037		559	56						53	450
2037	-	2038		587	59						56	472
2038	-	2039		616	62						59	495
2039	-	2040		647	65						62	520
2040	-	2041		679	68						65	546
2041	-	2042		713	71						68	574
2042	-	2043		749	75						71	603
2043	-	2044		786	79						75	632

Year			Construction cost	Rental Income	Maintenance Expenditure	Loan	IDC	Loan repayment	Bal Loan Amount	Interest on Loan @12%	Return @14% to the developer	Residual rental income to SPV
2044	-	2045		825	83						79	663
2045	-	2046		867	87						83	697
Total			922	12047	1208	738	89	827		543	1037	8248

Total Development Charges collected by PMC & PCMC during the year 2012-13 is approximately Rs 100 Cr. It is proposed to double these charges in order to credit the additional revenue to the Pune Metro. A modest 3% annual increase is assumed in order to estimate the revenue over 25 years beyond the commencement of the Operation of Metro. Thus at the starting year i.e. 2020-21 the revenue from this source is worked out as Rs 120 Cr. Total Stamp Duty and Registration Fees collection by the Govt of Maharashtra from PMC, PCMC and Cantonment areas expected in 2012-13 is approximately Rs 2900 Cr at the present rate of 5%. It is proposed to enhance registration charges from 5% to 6%. 75% out of the increased 1 % of this additional revenue is proposed to be credited to Metro revenue stream. A 3% annual increase is assumed in order to project the revenue over 25 years beyond the commencement of the Project. Thus at the starting year i.e. 2020-21 the revenue from this source is worked out as Rs 520 Cr. This is further enhanced by 3 % annually. **Table 12.8 (a)** brings out the projected revenue stream which has been incorporated while working out the FIRR under **Table 12.9.1 (b)**.

Table 12.8 (a) – Estimated generation of additional revenue from enhancement in Development Charges and surcharge on Registration fees and stamp duty on property sales
(in Rs Crore)

Year	ADDITIONAL REVENUE			
	Year from 2018-19	From Enhancement of Dev Charges	1% Cess on Registration	Total
2020-21	0	120	520	640
2021-22	1	124	536	659
2022-23	2	127	552	679
2023-24	3	131	568	699
2024-25	4	135	585	720
2025-26	5	139	603	742
2026-27	6	143	621	764
2027-28	7	148	640	787
2028-29	8	152	659	811
2029-30	9	157	678	835
2030-31	10	161	699	860
2031-32	11	166	720	886
2032-33	12	171	741	912
2033-34	13	176	764	940
2034-35	14	182	787	968
2035-36	15	187	810	997

Year	ADDITIONAL REVENUE			
	Year from 2018-19	From Enhancement of Dev Charges	1% Cess on Registration	Total
2036-37	16	193	834	1027
2037-38	17	198	859	1058
2038-39	18	204	885	1090
2039-40	19	210	912	1122
2040-41	20	217	939	1156
2041-42	21	223	967	1191
2042-43	22	230	996	1226
2043-44	23	237	1026	1263
2044-45	24	244	1057	1301
2045-46	25	251	1089	1340

Considering fare box revenue, advertisement, and revenue from additional Development charges and surcharge on stamp duty and registration fees on property sale; the **FIRR works out to 13.60% (Table 12.9.1(b))** The revenue through Property development and advertisement is expected to get accrued from development of property on metro stations and depot. It is possible to raise resources through leasing of parking rights at stations, advertisement on trains and tickets, advertisements within stations and parking lots, advertisements on viaducts, columns and other metro structures, co-branding rights to corporate, film shootings and special events on metro premises.

12.4 FINANCIAL INTERNAL RATE OF RETURN (FIRR)

Financial Internal Rate of Return (FIRR) under different Scenarios is tabulated below

Sr. No.	Description	FIRR	Table No.	Remarks
1	FIRR	6.87%	12.9.1(a)	
2	FIRR with additional revenue from increase in Development Charges by 100% and 1% surcharge on stamp duty & registration fees on sale of Property	13.60%	12.9.1(b)	Proposed to be adopted

Table 12.9.1 (a) - FIRR

(Rs. in Crore)

Year			Completion Cost	Additional Cost	Running Expenses	Replacement costs	Total Costs	Fare Box Revenue	PD & ADVT	Total Revenue	Net Cash flow for IRR
2016	-	2017	509				509			0	-509
2017	-	2018	1643				1643			0	-1643
2018	-	2019	2518				2518			0	-2518

Year			Completion Cost	Additional Cost	Running Expenses	Replacement costs	Total Costs	Fare Box Revenue	PD & ADVT	Total Revenue	Net Cash flow for IRR
2019	-	2020	2448				2448			0	-2448
2020	-	2021	2126		91		2217	188	19	207	-2010
2021	-	2022	1080		252		1332	563	56	619	-713
2022	-	2023	376		269		645	665	67	732	87
2023	-	2024	0	464	300		764	678	68	746	-18
2024	-	2025	0	0	320		320	789	79	868	548
2025	-	2026	0	0	341		341	804	80	884	543
2026	-	2027	0	0	364		364	943	94	1037	673
2027	-	2028	0	0	389		389	960	96	1056	667
2028	-	2029	0	0	415		415	1130	113	1243	828
2029	-	2030	0	0	444		444	1152	115	1267	823
2030	-	2031	0	0	474		474	1350	135	1485	1011
2031	-	2032	0	0	507		507	1375	138	1513	1006
2032	-	2033	0	0	542		542	1595	160	1755	1213
2033	-	2034	0	252	637		889	1611	161	1772	883
2034	-	2035	0	0	681		681	1879	188	2067	1386
2035	-	2036	0	0	728		728	1898	190	2088	1360
2036	-	2037	0	0	778		778	2202	220	2422	1644
2037	-	2038	0	0	833		833	2224	222	2446	1613
2038	-	2039	0	0	891		891	2582	258	2840	1949
2039	-	2040	0	0	954		954	2608	261	2869	1915
2040	-	2041	0	0	1021		1021	3032	303	3335	2314
2041	-	2042	0	0	1094		1094	3062	306	3368	2274
2042	-	2043	0	0	1172		1172	3548	355	3903	2731
2043	-	2044	0	0	1256	1692	2948	3584	358	3942	994
2044	-	2045	0	0	1347	1545	2892	4160	416	4576	1684
2045	-	2046	0	0	1445	0	1445	4202	420	4622	3177
Total			10700	716	17545	3237	32198	48784	4878	53662	6.87%

Table 12.9.1(b)- FIRR (with additional development charges and surcharge on stamp duty & registration fees)

(Rs. in Crore)

Year			Completion Cost	Additional Cost	Running Expenses	Replacement costs	Total Costs	Fare Box Revenue	PD & ADVT	Additional revenue from Dev Charges & Registration	Total Revenue	Net Cash flow for IRR
2016	-	2017	509				509				0	-509
2017	-	2018	1643				1643				0	-1643
2018	-	2019	2518				2518				0	-2518

Year			Completion Cost	Additional Cost	Running Expenses	Replacement costs	Total Costs	Fare Box Revenue	PD & ADVT	Additional revenue from Dev Charges & Registration	Total Revenue	Net Cash flow for IRR
2019	-	2020	2448				2448				0	-2448
2020	-	2021	2126		91		2217	188	19	640	847	-1370
2021	-	2022	1080		252		1332	563	-106	659	1116	-216
2022	-	2023	376		269		645	665	-68	679	1276	631
2023	-	2024	0	464	300		764	678	-33	699	1344	580
2024	-	2025	0	0	320		320	789	38	720	1547	1227
2025	-	2026	0	0	341		341	804	202	742	1748	1407
2026	-	2027	0	0	364		364	943	239	764	1946	1582
2027	-	2028	0	0	389		389	960	264	787	2011	1622
2028	-	2029	0	0	415		415	1130	304	811	2245	1830
2029	-	2030	0	0	444		444	1152	331	835	2318	1874
2030	-	2031	0	0	474		474	1350	380	860	2590	2116
2031	-	2032	0	0	507		507	1375	490	886	2751	2244
2032	-	2033	0	0	542		542	1595	530	912	3037	2495
2033	-	2034	0	252	637		889	1611	550	940	3101	2212
2034	-	2035	0	0	681		681	1879	596	968	3443	2762
2035	-	2036	0	0	728		728	1898	619	997	3514	2786
2036	-	2037	0	0	778		778	2202	670	1027	3899	3121
2037	-	2038	0	0	833		833	2224	694	1058	3976	3143
2038	-	2039	0	0	891		891	2582	753	1090	4425	3534
2039	-	2040	0	0	954		954	2608	781	1122	4511	3557
2040	-	2041	0	0	1021		1021	3032	849	1156	5037	4016
2041	-	2042	0	0	1094		1094	3062	880	1191	5133	4039
2042	-	2043	0	0	1172		1172	3548	958	1226	5732	4560
2043	-	2044	0	0	1256	1692	2948	3584	990	1263	5837	2889
2044	-	2045	0	0	1347	1545	2892	4160	1079	1301	6540	3648
2045	-	2046	0	0	1445	0	1445	4202	1117	1340	6659	5214
Total			11522	716	23727	3237	32198	48784	13126	24673	86583	13.60%

The various sensitivities with regard to increase/decrease in capital costs, O&M costs and revenues are placed in **Table 12.10** below :-

Table 12.10 - FIRR Sensitivity based on Table 12.9.1(b)

CAPITAL COSTS with Central Taxes			
10% increase in capital cost	20% increase in capital cost	10% decrease in capital cost	20% decrease in capital cost
12.65%	11.82%	14.68%	15.96%
REVENUE			
20% decrease in Traffic revenue	10% decrease in Traffic revenue	10% increase in Traffic revenue	20% increase in Traffic revenue
12.03%	12.84%	14.32%	15.02%
O&M COSTS			
10% increase in O&M cost		10% decrease in O&M cost	
13.34%		13.85%	

These sensitivities have been carried out independently for each factor.

12.5 FINANCING OPTIONS

12.5.1 Objectives of Funding

The objective of funding metro system is not necessarily enabling the availability of funds for construction but coupled with the objective of financial closure are other concerns, which are of no less importance: -

- Ensuring low project cost
- Ensuring debt funds at low rates of interest
- Creating self sustainable system in the long run by
 - Low infrastructure maintenance costs
 - Longer life span
 - Setting fares which minimise dependence on subsidies
- Recovering returns from both direct and indirect beneficiaries

- Rail based mass transit systems are characterised by heavy capital investments coupled with long gestation period leading to low financial rates of return although the economic benefits to the society are immense. Such systems generate externalities, which do not get captured in monetary terms and, therefore, do not flow back to the system. However, experience all over the world reveals that both construction and

operations of metro are highly subsidised. Government involvement in the funding of metro systems is a foregone conclusion. Singapore had a 100% capital contribution from the government, Hong Kong 78% for the first three lines and 66% for the later 2 lines. The Phase-I, Phase-II as well as Phase-III of Delhi MRTS project, Chennai, Bengaluru and Mumbai Line-3 metros projects are funded with mixture of equity by GOI & concerned state governments and step loan/soft loan (ODA)/Multilateral funding agencies.

12.5.2 Alternative Models Of Financing

The financing option shall depend upon selection of the dedicated agency created to implement the project. The prominent models are: -

- (i) Special Purpose Vehicle under the State Control (Delhi Metro Rail Corporation (DMRC) /Bangalore Metro Rail Corporation (BMRC) model)
- (ii) Public-Private Partnership (PPP) mode
 - Built Operate and Transfer (BOT) model
 - Other PPP Model

12.5.3 Financing Options:

Metro Rail Projects are highly capital intensive with long gestation period. Given the tariff constraints, they are not commercially attractive for investment. However, Delhi MRTS Phase-III project is estimated to give a high economic rate of return to the tune of 20%, which means investment on this project will be recovered by the city/society within 5 to 6 years time. Only a few metros in the world make operational profits and Delhi Metro is one of them. Thus, the Government involvement in the funding of metro systems is a foregone conclusion.

12.5.4 INTERNATIONAL EXPERIENCE:

Experience all over the world reveals that both construction and operations of a metro are highly subsidised and funded by the Government. Singapore had a 100% capital contribution from the government, Hong Kong 78% for the first three lines and 66% for the subsequent 2 lines. Others run on Governmental support and subsidies. Some of the metros which have access to tax levies are Sao Paulo, New York and Paris. If our capital city is to have Metro System on self sustainable basis, it is necessary to keep down the capital cost as much as possible by exempting taxes for the project and also required funding is made available from the Government sources. Financial patterns of some of the international metros are given below: -

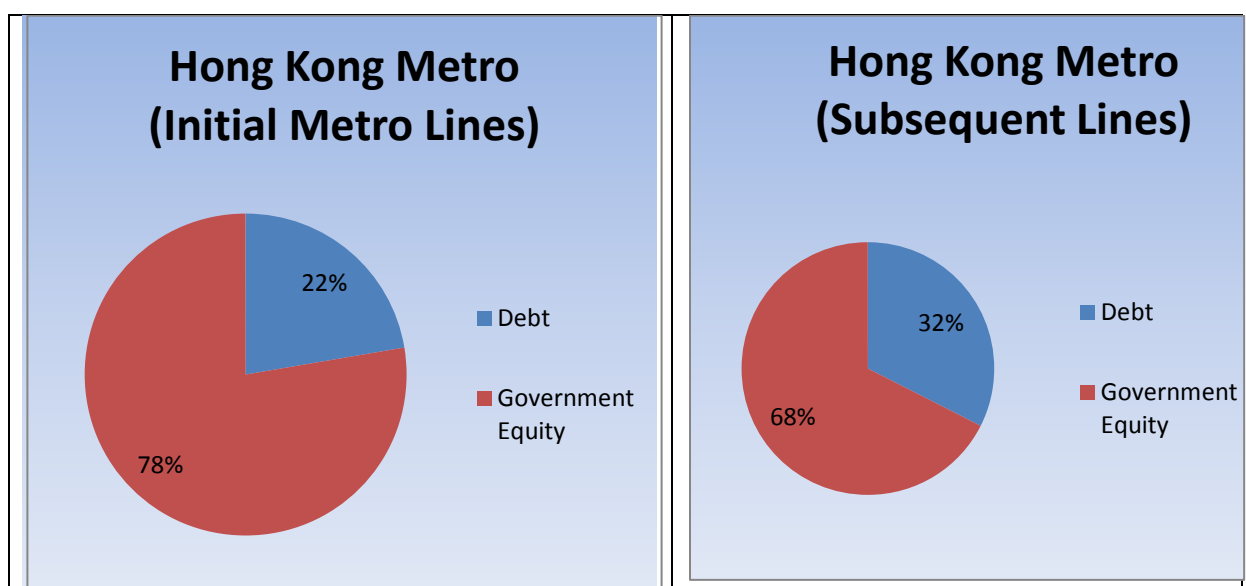
12.5.4.1 Hong Kong

In December 2007, the Kowloon Canton Rail Corporation (KCRC) was merged with the Hong Kong Metro; popularly known as MTR. After the merger, the metro system in Hong Kong has a network of 211.6 KMs. The Hong Kong Metro is one of the best examples of a metro system which gives quality service to the passengers and is making profits. The MTR also operates an airport express on dedicated high-speed rail link providing connections to the Hong Kong International Airport and the city. The MTR is widely recognized as a transporter of world class transport service that achieves high international standards in reliability, safety and efficiency. The MTR is engaged in a wide range of business activities in addition to railway operations. This includes development of residential and commercial projects, property leasing and revenue from advertising, telecom services and international consultancy services. The Hong Kong Metro carried 1205 million passengers in 2008 with a daily ridership of about 4 million.

During the year 2008, the Hong Kong Metro earned a net profit of 8284 million HK\$. In the year 2008, the fare revenue for the MTR lines amounted to HK\$ 11,467 million, whereas non-fare revenue was HK\$ 6,161 (from stations commercial, property rentals and management, etc).

The company has financed the construction & operation of MTR through equity funds from the government apart from debt financing and property development profits. Out of HK\$ 26 billion cost of initial MTR system, HK\$ 20.2 billion (nearly 78%) came from Hongkong Government while the remainder was obtained by MTRC through short & long term commercial loans, bond issues, various fund raising schemes and internal reserves. Similarly, for the last two lines, against the construction cost of HK\$ 35.1 billion, HK\$ 23.7 billion (68%) was funded by the Hongkong Government as an increase in capital to MTR while the remainder was obtained from loan sources external to MTRC. The government has taken initiative to meet the capital cost of Hong Kong metro but no support has been provided at the operations stage. However, support from the government has also come in the form of transfer of prime land along with the land required for the project. MTRC developed these lands and also reaped returns in the form of higher ridership due to this development. The fund generated from the development of these properties was used to finance construction costs. Moreover, properties developed along and on the alignment are used as a recurring source of income to supplement operating revenues. The funding pattern of initial metro line and Line-II is depicted in Figure 11.2 below

Figure 11.2 Funding Pattern of HK metro (Initial and subsequent lines)

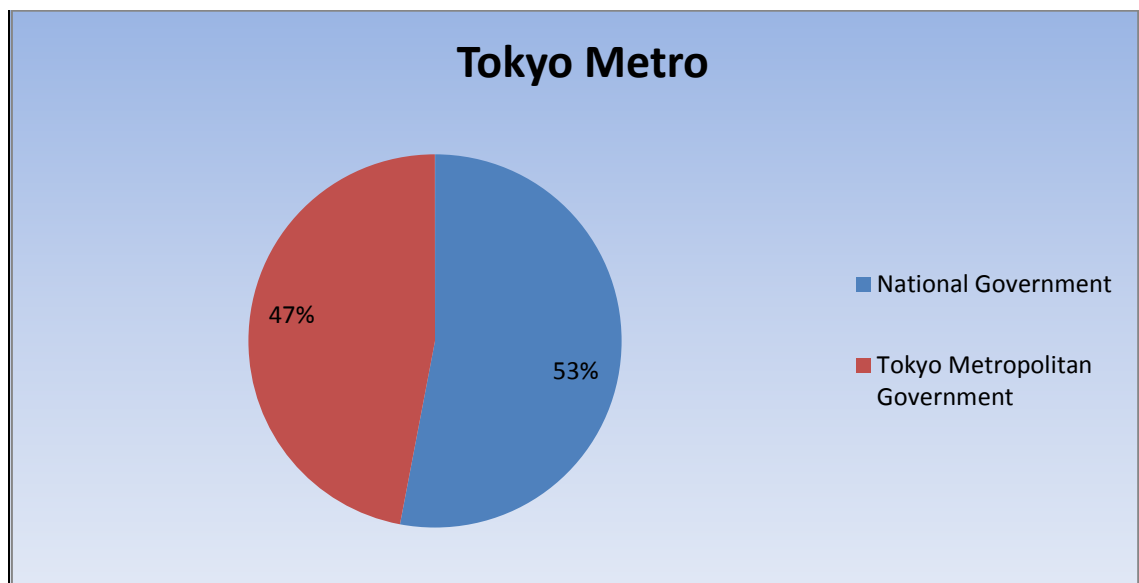


12.5.4.2 Metro Network at Tokyo

The metro network at Tokyo consists of 13 lines totalling 304.1 KMs which is managed by the Tokyo Metro, the Toei Subway and other private operators. The main operator is the Tokyo Metro which is the largest subway operator in Asia. It is jointly owned by the National Government (53%) and the Tokyo Metropolitan Government (47%) with a total capital deployment of 58.1 billion Yen. Tokyo Metro operates a network of 9 metro lines totalling 195.1 KMs. The other major metro operator in Tokyo is the Government of Tokyo, through the Tokyo Metropolitan Bureau of Transportation, which operates the Toei Subway- a network of 4 metro lines totalling 109 KMs. One unique feature of the metro in Tokyo is through-service (inter-running) with private railway companies. The subways were initially planned to replace the

streetcar network and the passengers travelling into the centre of Tokyo from the suburbs had to change trains at terminal stations. However, as the number of passengers increased, these stations became very congested. To solve this problem, through-services with JR (Japanese Railway) and private railway lines were started. At present, 10 lines have been connected to JR and private suburban lines at 16 points. The running of through-services has served multiple purposes viz. the inconvenience of changing trains by commuters has been eliminated, private railway operators gain access to central Tokyo and the new subway lines built at huge investment would get a fairly large demand from the very start from the users of the lines. The funding pattern of Tokyo Metro is depicted in Figure 11.3 below: -

Figure 11.3 Funding Pattern of Tokyo Metro



12.5.4.3 Singapore

The Singapore Mass Rapid Transit System represents a completely government owned model. The funds for financing the project were generated through traditional and innovative taxation measures. In departure to the funding approach adopted by the Hongkong system, the entire metro system was completely funded through budgetary support using innovative taxation mechanism. The Government was able to finance the entire initial construction phase by revenues generated through the taxation of the road transport sector and other general revenues. There is a clear-cut policy on the development and maintenance of metro systems. The government provides full infrastructure including rolling stock and another agency operates the system. The difference in replacement costs and historical cost of assets is met by the government. The nature of funding has led to a situation wherein the metro systems are not saddled with debt service obligations including repayment of loan. Some of the innovative measures implemented to limit the use of private cars i.e. decongestion and at the same time to garner resources for funding integrated transport infrastructure are given below: -

The Area License Scheme (ALS) later Electronic Road Pricing (ERP): - The Area License Scheme required all vehicles entering a designated restricted zone, consisting of the Central Business District (CBD), to display a license unless it was carrying at least 3 passengers. Charges were set on both the license as well as parking. The scheme was applicable during peak hours to begin

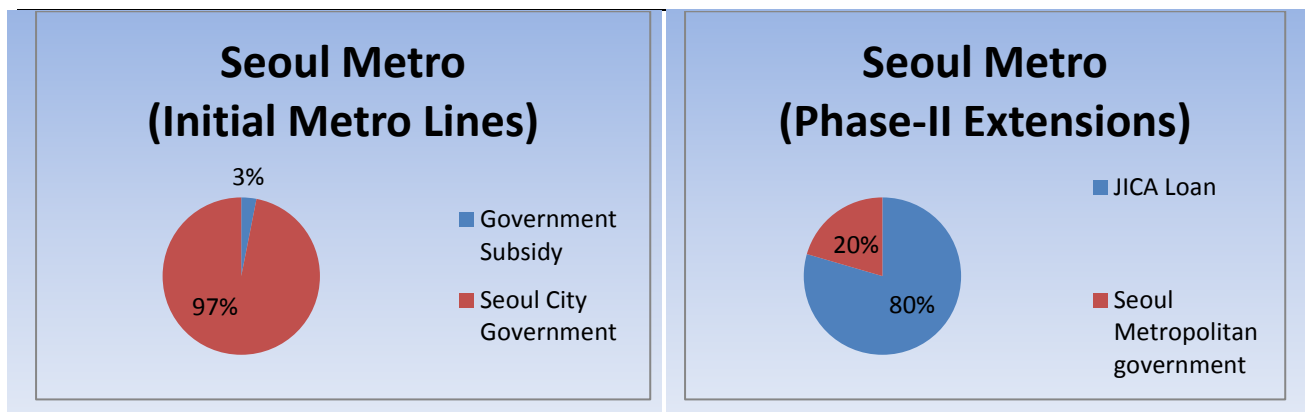
with, then later extended to the whole day. It was replaced by the (ERP) scheme in 1998, whereby the toll is automatically paid by a car entering licensed area.

The Vehicle Quota System (VQS): - The Vehicle Quota system sought to contain vehicle population growth within acceptable limits. A limited number of additional licenses are auctioned every quarter. Prospective vehicle owners are required to bid for these and procure a ten year license. Companies are charged twice the rate for private individuals. The schemes were successful in halving the vehicle population growth rates.

12.5.4.4 Seoul

The Seoul Metropolitan Government (SMG) is the agency which oversees the construction of the metro in Seoul. The operations are handled by two public sector corporations-Seoul Metropolitan Subway Corporation and Seoul Metropolitan Rapid Transit Corporation. At present, the metro consists of 8 lines covering a distance of 286.90 KMs carrying 4.50 million passengers on an average per day during the year 2009. The Seoul metro has been financed from various sources like central government, city government, OECF (now World Bank and AIIB) borrowings, subway bonds, taxes from various traffic demand measures. The subway and metro rail system in Seoul so far has been funded, built and operated under government ownership with Seoul metropolitan government footing most of the bill. The funding pattern of initial and subsequent metro lines is depicted in Figure 10.4 below: -

Figure 11.4 Funding Pattern of Seoul Metro



12.5.5 DMRC/BMRC/CMRL pattern of Financing

A Special Purpose Vehicle (SPV) is to be set up for the implementation of the project and for its subsequent Operation & Maintenance. Under this arrangement Government of India and Government of Maharashtra shall make equal equity contribution and run the SPV as a commercial enterprise as a joint venture of GOI & GOM. As per the prevalent practice, Central Government may be willing to contribute 15% to 20% of the project cost as their equity contribution. An equal amount can be contributed by Government of Maharashtra aggregating the total equity to 40%. With the equal ownership of the SPV, both the governments nominate their representatives as members of the Board of Directors, which in turn select functional directors. Such a SPV has a benefit of independent management under the aegis of Indian Companies Act, 2013. Delhi Metro Rail Corporation, Chennai & Bangalore metro corporations are shining example of such SPV. For the balance 60% funding requirement, options available are as follows: -

- (i) **Subordinate Debt:** - For Delhi Metro, land and rehabilitation and resettlement cost have been borne by GOI & GNCTD equally as interest free subordinate debt. Now, MOUD have changed the policy under which the cost of land for Bangalore Metro was borne by Government of Karnataka as interest free subordinate debt. Similarly, the cost of Land including rehabilitation and resettlement cost amounting to Rs. 932.00 Crore may be contributed as interest free subordinate debt by GOM/ULB. This mezzanine financing is of extreme help in quickening the pace of land acquisition, since the compensation amount is released to evacuate instantaneously. The loan is of longer duration and becomes repayable only after other long term loans raised for the project is repaid.
- (ii) **Debt:** - The balance cost is to be met through loans from various institutions namely World Bank and AIIB, domestic borrowing, loans from World Bank / AIIB and Suppliers Credit etc.

WORLD BANK AND AIIB Loan: - Overseas Development assistance from Japan International Cooperation Agency (WORLD BANK AND AIIB) may be availed of for the Pune metro rail projects with interest @ 1.40%PA (excluding onetime front end fee @0.20% on the sanctioned loan) by GOI and lend it to the SPV on back to back basis. The loan is repayable in 30 years including moratorium period of 10 years. The loan is being provided by WORLD BANK AND AIIB to GOI which in turn releases the same to SPV under a Pass Through Assistance (PTA) mechanism. Normally, WORLD BANK AND AIIB funds for underground civil works, Electrical, Signalling & Telecom and Rolling Stock only. Since the loan will be in Japanese Yen, fluctuation in exchange rate at the time of repayment shall be borne by the Central Government and Government of Maharashtra in proportion to which their share holding. Alternatively, WORLD BANK AND AIIB can release the loan to the SPV for which a sovereign guarantee will be required from Central Government. Foreign exchange variation in such eventuality will be borne either by the SPV or GOM. In either case loan shall be repaid by SPV from the income streams of metro operations.

Modified WORLD BANK AND AIIB Loan: The union cabinet chaired by the PM has given its approval for modification of existing guidelines of the policy on bilateral official development assistance for Development Corporation from with bilateral partners. As per the discussions with WORLD BANK AND AIIB officials, WORLD BANK AND AIIB will extend only modified step loan for the new projects in India at an interest rate of 0.30% per annum. The tenure of the loan is 40 years with 10 years moratorium period. WORLD BANK AND AIIB shall fund the project to the extent of 85% of the cost of the project excluding the cost of the land, cost of Rehabilitation and Resettlement and taxes and duties. In case WORLD BANK AND AIIB agree to fund the project, the full loan i.e., Rs. 5595 crore shall be fund by WORLD BANK AND AIIB. In that case there will be no need to borrow from Market Borrowing.

Loan from Asian Development Bank (WORLD BANK AND AIIB): - The Loan shall be available from World Bank/AIIB, but as per the experience it's processing and approval normally takes 8-12 months. The interest rate is linked with prevailing 6 monthly LIBOR. These bilateral funding institutions also charge some margin ranging from 200 basis points to 300 basis points. Loan from these institutions may delay the implementation of the project resulting

in avoidable increase in the completion cost due to time taken during finalization of loan agreement. Recently, Bangalore Metro availed ADB loan, however loan is yet to be disburse.

Loan from Bank and Financial Institutions: - Funds can be arranged from domestic Financial Institutions like India Infrastructure Finance Company Limited (IIFCL), India Development Financing Corporation (IDFC), Life Insurance Corporation of India (LIC), IDBI Bank, ICICI Bank Ltd etc. These institutions are increasingly engaged to fund infrastructure projects subject to their commercial viability against guarantee from GOI. There are many models available under which the funds can be arranged by these financial institutions with or without syndicating with other commercial banks. IIFCL e.g. fund 20% of the project cost and arrange balance through the syndication of commercial banks with a lead banker among the consortium of bankers. The loan can be given for a period of 20-30 years with interest rate ranging from 9.50% to 12% PA. IIFCL can also provide 100% funding against GOI guarantee. They arrange ECB to the extent of foreign currency requirement at very competitive rate. The funding arrangement may require the central government guarantee as well. Since the rate of interest of these financial institutions is much higher than the interest rates of soft loan provided by WORLD BANK AND AIIB considering the exchange rate variation will be to GOI & GOM account, GOI and GOM shall have to bear the interest difference and provide suitable subsidy to the SPV to make the project financially sustainable.

Suppliers Credit: - Suppliers Credit is an established method to secure funding of imports. It is backed by EXIM banks of exporting countries and is often a much better instrument than bilateral aid. While bilateral aid ties the borrowing entity, Suppliers Credit can be used intelligently and effectively to spur competition in competitive international tendering method. In case of Rolling Stock, where market is truly competitive (unlike S&T) an attractive rate of interest for suppliers credit is possible. However, the supplier will load the amount of interest in the cost of supply due to which the effective completion cost will be very high leading to increase in the initial completion cost.

The funding pattern assumed under government owned SPV model is placed in **Table 12.11** as under:-

Table 12.11 - Funding pattern under SPV model (with Taxes & Duties)

Particulars	With Taxes & Duties	
	Amount (Rs/Crore)	% Of contribution
Equity By GOI	1310.00	13.41%
Equity By GOM	1310.00	13.41%
SD for CT by GOM (50%)	644.00	6.59%
SD for CT by GOI (50%)	644.00	6.59%
Grant by Local Bodies	28.50	0.30%
PTA against WORLD BANK AND AIIB Loan @ 0.30% PA	5831.50	59.70%
Total	9768.00	100.00%
SD by GOM for Land including R&R cost and State taxes	302.20	
Subordinate Debts for Land including R&R cost and State Taxes From ULB	1210.80	
Total	11281.00	
Additional PTA for Interest during Construction (IDC)	139.00	WORLD BANK AND AIIB Loan @ 1.40%
Grand Total	11420.00	

12.5.6 Public Private Partnership Mode

Public Private Partnership (PPP) arrangements are steadily growing in use particularly in road, power, and telecom sectors which are more of commercial nature rather than in a social sector project. PPP models are arrayed across a spectrum ranging from BOT where the private sectors have total involvement to other tailor made models where both public and private sector assume separate responsibilities. A few alternatives which can be selected in this regard are: -

BOT Model: - In this model, the private firm will be responsible for financing, designing, building, operating and maintaining of the entire project. The contribution of Government of Maharashtra will be limited to cost of land only. Such a project become eligible for Viability Gap Funding (VGF) upto 20% from the Central Government provided the state government also contribute same amount towards the project. The metro being a social sector project may not attract much private parties. Besides quite expectedly the private operator may demand assured rate of return in the range of 16% to 18% (Equity IRR) or a comfort of guaranteed ridership etc.

The funding pattern assumed under this model to ensure 18% as EIRR is placed in **Table 12.12.1** tabulated as under: -

Table 12.12.1 - Funding pattern under BOT model

Particulars	Amount (Rs/Crore)	% of contribution
VGF by GOI	1954.00	20.00%
VGF by GOM	4046.00	41.42%
Equity by Concessionaire	1256.00	12.86%
Concessionaire's debt @12% PA	2512.00	25.72%
Total	9768.00	100.00%
Land Free by GOM/ULB	932.00	
Total	10700.00	
IDC	436.00	
State Taxes by GOM/ULB	581.00	
Total including IDC	11717.00	

12.6. RECOMMENDATIONS

The FIRR of subject metro with central taxes is positive i.e., 6.87% (when PD and other income is not considered) and with PD and additional income the FIRR is 13.60%. Therefore the corridors are recommended for implementation with additional income. FIRR has been calculated without taking in to account the revenue from sale of additional FAR.

The total fund contribution of GOI & GOM under various alternatives is tabulated in table 12.12.3.

Table 12.12.3 - Fund Contribution of GOI & GOM

Particulars	(Rs. In crore)	
	SPV Model	BOT
GOI	1954.00	1954.00
GOM & State's/ULB other contributions	3495.50	5559.00
Total	5449.50	7513.00

The state tax amounting to Rs.630 crore is either to be exempted or reimbursed by the State Government. Considering the difference, it is recommended to implement the project under SPV model as per the funding pattern given in Table 12.11.

The following cash flow statement with & without additional income , BOT model to ensure 18% EIRR when the project cost is with central taxes and PD earnings are shown respectively in Table 12.13, 12.14, 12.15, 12.16 and 12.17 as detailed below:

Table 12.1.3 Cash Flow showing FIRR without additional income and WORLD BANK AND AIIB loan @1.40%,

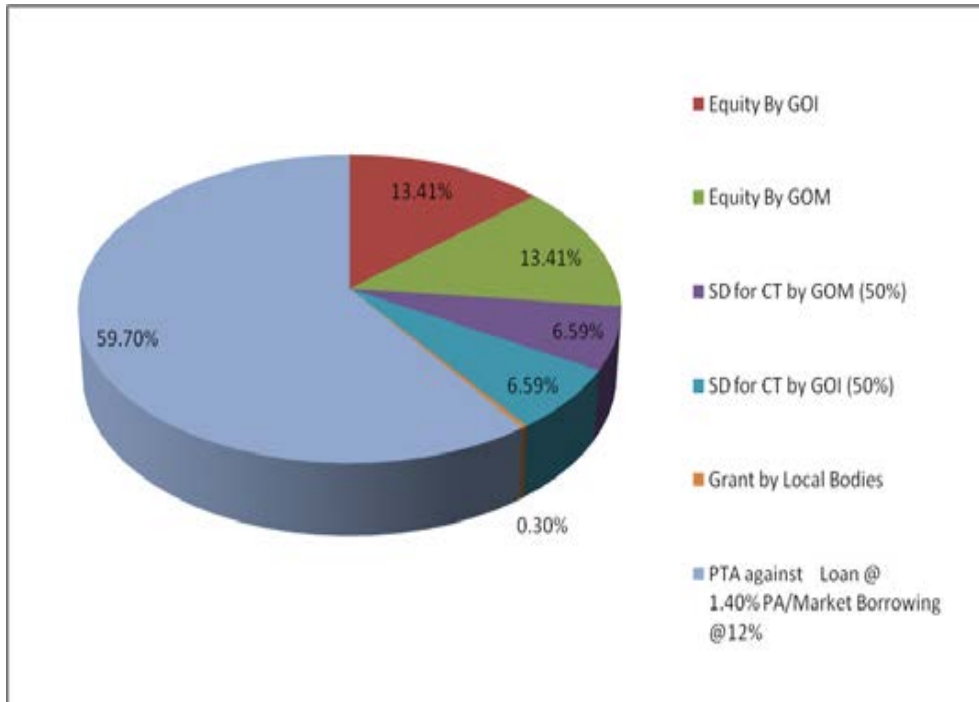
Table 12.14 Cash Flow showing FIRR without additional income and WORLD BANK AND AIIB loan @ 0.30%

Table 12.15 Cash Flow showing FIRR with additional income and WORLD BANK AND AIIB loan @ 1.40%

Table 12.16 Cash Flow showing FIRR with additional income and Market Borrowing @ 12%
Table 12.17 Cash Flow showing BOT model with 18% EIRR.

The funding pattern assumed under SPV model is depicted in the pie chart i.e., Figure 12.2 as under:
-

Figure 12.2 Funding Pattern - SPV Model



PUNE METRO PROJECT				I	II												Rate	Loan %	Upfront Fee				Table 11.14
CAPITAL COST-FIXED				9221	6072	3149											Market Borrowings	12.00%	#REF!	0.20%			
CAPITAL COST - CURRENT				10700	7071	3629											JICA Loan	1.40%	100.00%	0.00%			
DOMESTIC FUNDING - BASE CASE																							
Year	Completion Cost	Additional Capital	Running Expenses	Depreciation	Replacement Cost	Total Cost	Fare box Revenue	Revenue From advertisement, Kiosk etc.	Total Revenue	Net Cash Flow for IRR	Equity from GOI & GOM	Availability of cash	Cumulative cash	Cum. Loan	Loan	Repayment of Loan	IDC on JICA Loan	IDC on MB	Cumulative loan incl. IDC	Interest	Profit before Tax	Cash Balance	Cumulative Cash
1	2	3	4	5	6	7	8	9	10	11	12	13	14	15	16	17	18	19	20	21	22	23	24
2016 - 2017	509					509			0	-509	440	-70	-70	70	70	0	12	#REF!	#REF!				
2017 - 2018	1643					1643			0	-1643	1073	-570	-640	640	570	0	5	#REF!	#REF!				
2018 - 2019	2518					2518			0	-2518	1072	-1446	-2086	2086	1446	0	19	#REF!	#REF!				
2019 - 2020	2448					2448			0	-2448	762	-1686	-3772	3772	1686	0	41	#REF!	#REF!				
2020 - 2021	2126		91		212	2217	188	19	207	-2010	762	-1364	-5136	5136	1364	0	62	#REF!	#REF!	0	-96	116	116
2021 - 2022	1080		252		321	1332	563	56	619	-713	760	-320	-5456	5456	320	0	0	#REF!	#REF!	#REF!	#REF!	#REF!	#REF!
2022 - 2023	376		269		321	645	665	67	732	87	0	-376	-5832	5832	376	0	0	#REF!	#REF!	#REF!	#REF!	#REF!	#REF!
2023 - 2024	0	464	300		335	764	678	68	746	-18	0	0	0	0	0	#REF!	0	#REF!	#REF!	#REF!	#REF!	#REF!	#REF!
2024 - 2025	0	0	320		335	320	789	79	868	548	0	0	0	0	0	#REF!	0	#REF!	#REF!	#REF!	#REF!	#REF!	#REF!
2025 - 2026	0	0	341		335	341	804	80	884	543	0	0	0	0	0	#REF!	0	#REF!	#REF!	#REF!	#REF!	#REF!	#REF!
2026 - 2027	0	0	364		335	364	943	94	1037	673	0	0	0	0	0	#REF!	0	#REF!	#REF!	#REF!	#REF!	#REF!	#REF!
2027 - 2028	0	0	389		335	389	960	96	1056	667	0	0	0	0	0	#REF!	0	#REF!	#REF!	#REF!	#REF!	#REF!	#REF!
2028 - 2029	0	0	415		335	415	1130	113	1243	828	0	0	0	0	0	#REF!	0	#REF!	#REF!	#REF!	#REF!	#REF!	#REF!
2029 - 2030	0	0	444		335	444	1152	115	1267	823	0	0	0	0	0	#REF!	0	#REF!	#REF!	#REF!	#REF!	#REF!	#REF!
2030 - 2031	0	0	474		335	474	1350	135	1485	1011	0	0	0	0	0	#REF!	0	#REF!	#REF!	#REF!	#REF!	#REF!	#REF!
2031 - 2032	0	0	507		335	507	1375	138	1513	1006	0	0	0	0	0	#REF!	0	#REF!	#REF!	#REF!	#REF!	#REF!	#REF!
2032 - 2033	0	0	542		335	542	1595	160	1755	1213	0	0	0	0	0	#REF!	0	#REF!	#REF!	#REF!	#REF!	#REF!	#REF!
2033 - 2034	0	252	637		343	889	1611	161	1772	883	0	0	0	0	0	299	0	#REF!	#REF!	#REF!	#REF!	#REF!	#REF!
2034 - 2035	0	0	681		343	681	1879	188	2067	1386	0	0	0	0	0	299	0	#REF!	#REF!	#REF!	#REF!	#REF!	#REF!
2035 - 2036	0	0	728		343	728	1898	190	2088	1360	0	0	0	0	0	299	0	#REF!	#REF!	#REF!	#REF!	#REF!	#REF!
2036 - 2037	0	0	778		343	778	2202	220	2422	1644	0	0	0	0	0	299	0	#REF!	#REF!	#REF!	#REF!	#REF!	#REF!
2037 - 2038	0	0	833		343	833	2224	222	2446	1613	0	0	0	0	0	299	0	#REF!	#REF!	#REF!	#REF!	#REF!	#REF!
2038 - 2039	0	0	891		343	891	2582	258	2840	1949	0	0	0	0	0	299	0	#REF!	#REF!	#REF!	#REF!	#REF!	#REF!
2039 - 2040	0	0	954		343	954	2608	261	2869	1915	0	0	0	0	0	299	0	#REF!	#REF!	#REF!	#REF!	#REF!	#REF!
2040 - 2041	0	0	1021		343	1021	3032	303	3335	2314	0	0	0	0	0	299	0	#REF!	#REF!	#REF!	#REF!	#REF!	#REF!
2041 - 2042	0	0	1094		343	1094	3062	306	3368	2274	0	0	0	0	0	299	0	#REF!	#REF!	#REF!	#REF!	#REF!	#REF!
2042 - 2043	0	0	1172		343	1172	3548	355	3903	2731	0	0	0	0	0	299	0	#REF!	#REF!	#REF!	#REF!	#REF!	#REF!
2043 - 2044	0	0	1256		394	1692	2948	3584	358	3942	994	0	0	0	0	299	0	#REF!	#REF!	#REF!	#REF!	#REF!	#REF!
2044 - 2045	0	0	1347		440	1545	2892	4160	416	4576	1684	0	0	0	0	299	0	#REF!	#REF!	#REF!	#REF!	#REF!	#REF!
2045 - 2046	0	0	1445		440	0	1445	4202	420	4622	3177	0	0	0	0	#REF!	0	#REF!	#REF!	#REF!	#REF!	#REF!	#REF!
	10700	716	17545		8908	3237	32198	48784	4878	53662	6.87%	4869			5832	#REF!	139	#REF!	#REF!	#REF!	#REF!	#REF!	#REF!
											21464												

PUNE METRO PROJECT																			Rate	Loan %	Upfront Fee	Table 11.14	
CAPITAL COST-FIXED																			0.30%	100.00%	0.20%		
CAPITAL COST - CURRENT																			Period	30+10	40 years		
DOMESTIC FUNDING - BASE CASE																							
Year	Completion Cost	Additional Capital	Running Expenses	Depreciation	Replacement Cost	Total Cost	Fare box Revenue	Revenue From advertisement, Kiosk etc.	Total Revenue	Net Cash Flow for IRR	Equity from GOI & GOM	Availability of cash	Cumulative cash	Cum. Loan	Loan	Repayment of Loan	IDC on JICA	Cumulative loan incl. IDC	Interest	Profit before Tax	Cash Balance	Cumulative Cash	
1	2	3	4	5	6	7	8	9	10	11	12	13	14	15	16	17	19	20	21	22	23	24	
2016 - 2017	509					509			0	-509	440	-70	-70	70	70	0	0	70					
2017 - 2018	1643					1643			0	-1643	1073	-570	-640	640	570	0	1	641					
2018 - 2019	2518					2518			0	-2518	1072	-1446	-2086	2086	1446	0	4	2091					
2019 - 2020	2448					2448			0	-2448	762	-1686	-3772	3772	1686	0	9	3786					
2020 - 2021	2126		91		212	2217	188	19	207	-2010	762	-1364	-5136	5136	1364	0	13	5163	11	-107	105	105	
2021 - 2022	1080		252		321	1332	563	56	619	-713	760	-320	-5456	5456	320	0		5483	15	31	352	456	
2022 - 2023	376		269		321	645	665	67	732	87	0	-376	-5832	5832	376	0		5859	16	126	447	903	
2023 - 2024	0	464	300		335	764	678	68	746	-18		0	0	0	0	0		5859	18	93	-36	867	
2024 - 2025	0	0	320		335	320	789	79	868	548		0	0	0	0	0		5859	18	195	530	1398	
2025 - 2026	0	0	341		335	341	804	80	884	543		0	0	0	0	0		5859	18	190	525	1923	
2026 - 2027	0	0	364		335	364	943	94	1037	673		0	0	0	0	194		5664	18	320	461	2384	
2027 - 2028	0	0	389		335	389	960	96	1056	667		0	0	0	0	194		5470	17	315	456	2840	
2028 - 2029	0	0	415		335	415	1130	113	1243	828		0	0	0	0	194		5275	16	477	617	3457	
2029 - 2030	0	0	444		335	444	1152	115	1267	823		0	0	0	0	194		5081	16	472	613	4070	
2030 - 2031	0	0	474		335	474	1350	135	1485	1011		0	0	0	0	194		4887	15	661	801	4871	
2031 - 2032	0	0	507		335	507	1375	138	1513	1006		0	0	0	0	194		4692	15	656	797	5668	
2032 - 2033	0	0	542		335	542	1595	160	1755	1213		0	0	0	0	194		4498	14	864	1005	6673	
2033 - 2034	0	252	637		343	889	1611	161	1772	883		0	0	0	0	194		4303	13	779	675	7348	
2034 - 2035	0	0	681		343	681	1879	188	2067	1386		0	0	0	0	194		4109	13	1030	1179	8526	
2035 - 2036	0	0	728		343	728	1898	190	2088	1360		0	0	0	0	194		3915	12	1005	1153	9680	
2036 - 2037	0	0	778		343	778	2202	220	2422	1644		0	0	0	0	194		3720	12	1289	1438	11118	
2037 - 2038	0	0	833		343	833	2224	222	2446	1613		0	0	0	0	194		3526	11	1259	1407	12525	
2038 - 2039	0	0	891		343	891	2582	258	2840	1949		0	0	0	0	194		3332	11	1595	1744	14269	
2039 - 2040	0	0	954		343	954	2608	261	2869	1915		0	0	0	0	194		3137	10	1562	1711	15980	
2040 - 2041	0	0	1021		343	1021	3032	303	3335	2314		0	0	0	0	194		2943	9	1962	2110	18090	
2041 - 2042	0	0	1094		343	1094	3062	306	3368	2274		0	0	0	0	194		2748	9	1922	2071	20161	
2042 - 2043	0	0	1172		343	1172	3548	355	3903	2731		0	0	0	0	194		2554	8	2380	2528	22689	
2043 - 2044	0	0	1256		394	1692	2948	3584	358	3942	994		0	0	0	194		2360	8	2284	792	23481	
2044 - 2045	0	0	1347		440	1545	2892	4160	416	4576	1684		0	0	0	194		2165	7	2782	1483	24963	
2045 - 2046	0	0	1445		440	0	1445	4202	420	4622	3177		0	0	0	194		1971	6	2731	2976	27940	
		10700	716	17545	8908	3237	32198	48784	4878	53662	6.87%	4869			5832	3888	27		337	26872	27940		
										21464													

PUNE METRO PROJECT				I		II												Rate		Loan %		Upfront Fee		Table 11.14	
CAPITAL COST-FIXED				9221		6072		3149								Market Borrowings		12.00%		4.00%		0.20%			
CAPITAL COST - CURRENT				10700		7071		3629								JICA Loan		1.40%		96.00%		0.00%			
DOMESTIC FUNDING - BASE CASE																									
Year	Completion Cost	Additional Capital	Running Expenses	Depreciation	Replacement Cost	Total Cost	Fare box Revenue	Revenue From advertisement, Kiosk etc.	Income From Property Development	Total Revenue	Net Cash Flow for IRR	Equity from GOI & GOM	Availability of cash	Cumulative cash	Cum. Loan	Loan	Repayment of Loan	IDC on JICA Loan	IDC on MB	Cumulative loan incl. IDC	Interest	Profit before Tax	Cash Balance	Cumulative Cash	
1	2	3	4	5	6	7	8	9	10	11	12	13	14	15	16	17	18	19	20	21	22	23	24	25	
2016 - 2017	509					509				0	-509	440	-70	-70	70	70	0	12	0	82					
2017 - 2018	1643					1643				0	-1643	1073	-570	-640	640	570	0	5	2	659					
2018 - 2019	2518					2518				0	-2518	1072	-1446	-2086	2086	1446	0	18	7	2130					
2019 - 2020	2448					2448				0	-2448	762	-1686	-3772	3772	1686	0	39	14	3869					
2020 - 2021	2126		91		213	2217	188	19	0	207	-2010	762	-1364	-5136	5136	1364	0	60	21	5314	0	-97	116	116	
2021 - 2022	1080		252		322	1332	563	56	-162	457	-875	760	-320	-5456	5456	320	0	0	0	5634	638	-755	-433	-317	
2022 - 2023	376		269		322	645	665	67	-135	597	-48	0	-376	-5832	5832	376	0	0	6010	676	-670	-348	-665		
2023 - 2024	0	464	300		336	764	678	68	-101	645	-119		0	0	0	0	28	0	5981	721	-712	-868	-1533		
2024 - 2025	0	0	320		336	320	789	79	-41	827	507		0	0	0	0	28	0	5953	718	-547	-239	-1772		
2025 - 2026	0	0	341		336	341	804	80	122	1006	665		0	0	0	0	28	0	5925	714	-385	-77	-1849		
2026 - 2027	0	0	364		336	364	943	94	145	1182	818		0	0	0	0	315	0	5611	711	-229	-208	-2057		
2027 - 2028	0	0	389		336	389	960	96	168	1224	835		0	0	0	0	315	0	5296	673	-174	-153	-2209		
2028 - 2029	0	0	415		336	415	1130	113	191	1434	1019		0	0	0	0	315	0	4982	636	47	69	-2141		
2029 - 2030	0	0	444		336	444	1152	115	216	1483	1039		0	0	0	0	315	0	4667	598	105	127	-2014		
2030 - 2031	0	0	474		336	474	1350	135	245	1730	1256		0	0	0	0	315	0	4353	560	360	381	-1632		
2031 - 2032	0	0	507		336	507	1375	138	352	1865	1358		0	0	0	0	315	0	4038	522	500	521	-1111		
2032 - 2033	0	0	542		336	542	1595	160	370	2125	1583		0	0	0	0	315	0	3724	485	762	784	-327		
2033 - 2034	0	252	637		344	889	1611	161	389	2161	1272		0	0	0	0	286	0	3437	447	733	539	211		
2034 - 2035	0	0	681		344	681	1879	188	408	2475	1794		0	0	0	0	286	0	3151	412	1038	1095	1306		
2035 - 2036	0	0	728		344	728	1898	190	429	2517	1789		0	0	0	0	286	0	2865	378	1067	1124	2431		
2036 - 2037	0	0	778		344	778	2202	220	450	2872	2094		0	0	0	0	286	0	2578	344	1406	1464	3895		
2037 - 2038	0	0	833		344	833	2224	222	472	2918	2085		0	0	0	0	286	0	2292	309	1432	1489	5384		
2038 - 2039	0	0	891		344	891	2582	258	495	3335	2444		0	0	0	0	286	0	2005	275	1825	1883	7266		
2039 - 2040	0	0	954		344	954	2608	261	520	3389	2435		0	0	0	0	286	0	1719	241	1850	1908	9174		
2040 - 2041	0	0	1021		344	1021	3032	303	546	3881	2860		0	0	0	0	286	0	1432	206	2310	2367	11542		
2041 - 2042	0	0	1094		344	1094	3062	306	574	3942	2848		0	0	0	0	286	0	1146	172	2332	2390	13931		
2042 - 2043	0	0	1172		344	1172	3548	355	603	4506	3334		0	0	0	0	286	0	859	137	2853	2910	16841		
2043 - 2044	0	0	1256		395	1692	2948	358	632	4574	1626		0	0	0	0	286	0	573	103	2820	1236	18078		
2044 - 2045	0	0	1347		441	1545	2892	416	663	5239	2347		0	0	0	0	286	0	286	69	3382	1992	20070		
2045 - 2046	0	0	1445		441	0	1445	4202	697	5319	3874		0	0	0	0	286	0	0	34	3399	3553	23623		
	10700	716	17545		8934	32198	48784	4878	8248	61910	8.23%	4869				5832	6010	134	44	10780	24651	23623			
											29712														

PUNE METRO PROJECT				I	II													Rate	Loan %	Upfront Fee	Table 11.14				
CAPITAL COST-FIXED				9221	6072	3149												Market Borrowings	12.00%	4.00%	0.20%				
CAPITAL COST - CURRENT				10700	7071	3629												JICA Loan	1.40%	96.00%	0.00%				
DOMESTIC FUNDING - BASE CASE																									
Year	Completion Cost	Additional Capital	Running Expenses	Depreciation	Replacement Cost	Total Cost	Fare box Revenue	Revenue From advertisement, Kiosk etc.	Additional revenue from Dev Charges & Registration	Total Revenue	Net Cash Flow for IRR	Equity from GOI & GOM	Availability of cash	Cumulative cash	Cum. Loan	Loan	Repayment of Loan	IDC on JICA Loan	IDC on MB	Cumulative loan incl. IDC	Interest	Profit before Tax	Cash Balance	Cumulative Cash	
1	2	3	4	5	6	7	8	9	10	11	12	13	14	15	16	17	18	19	20	21	22	23	24	25	
2016 - 2017	509					509				0	-509	440	-70	-70	70	70	0	12	0	82					
2017 - 2018	1643					1643				0	-1643	1073	-570	-640	640	570	0	5	2	659					
2018 - 2019	2518					2518				0	-2518	1072	-1446	-2086	2086	1446	0	18	7	2130					
2019 - 2020	2448					2448				0	-2448	762	-1686	-3772	3772	1686	0	39	14	3869					
2020 - 2021	2126		91		213	2217	188	19	640	847	-1370	762	-1364	-5136	5136	1364	0	60	21	5314	0	543	756	756	
2021 - 2022	1080		252		322	1332	563	56	659	1278	-54	760	-320	-5456	5456	320	0	0		5634	638	67	389	1145	
2022 - 2023	376		269		322	645	665	67	679	1411	766	0	-376	-5832	5832	376	0	0		6010	676	144	466	1611	
2023 - 2024	0	464	300		336	764	678	68	699	1445	681		0	0	0	0	28	0		5981	721	88	-68	1543	
2024 - 2025	0	0	320		336	320	789	79	720	1588	1268		0	0	0	0	28	0		5953	718	215	523	2065	
2025 - 2026	0	0	341		336	341	804	80	742	1626	1285		0	0	0	0	28	0		5925	714	235	542	2608	
2026 - 2027	0	0	364		336	364	943	94	764	1801	1437		0	0	0	0	315	0		5611	711	390	412	3019	
2027 - 2028	0	0	389		336	389	960	96	787	1843	1454		0	0	0	0	315	0		5296	673	445	466	3486	
2028 - 2029	0	0	415		336	415	1130	113	811	2054	1639		0	0	0	0	315	0		4982	636	667	689	4174	
2029 - 2030	0	0	444		336	444	1152	115	835	2102	1658		0	0	0	0	315	0		4667	598	724	746	4920	
2030 - 2031	0	0	474		336	474	1350	135	860	2345	1871		0	0	0	0	315	0		4353	560	975	997	5917	
2031 - 2032	0	0	507		336	507	1375	138	886	2399	1892		0	0	0	0	315	0		4038	522	1034	1055	6972	
2032 - 2033	0	0	542		336	542	1595	160	912	2667	2125		0	0	0	0	315	0		3724	485	1305	1326	8298	
2033 - 2034	0	252	637		344	889	1611	161	940	2712	1823		0	0	0	0	286	0		3437	447	1384	1090	9388	
2034 - 2035	0	0	681		344	681	1879	188	968	3035	2354		0	0	0	0	286	0		3151	412	1598	1655	11043	
2035 - 2036	0	0	728		344	728	1898	190	997	3085	2357		0	0	0	0	286	0		2865	378	1635	1693	12735	
2036 - 2037	0	0	778		344	778	2202	220	1027	3449	2671		0	0	0	0	286	0		2578	344	1983	2041	14776	
2037 - 2038	0	0	833		344	833	2224	222	1058	3504	2671		0	0	0	0	286	0		2292	309	2017	2075	16851	
2038 - 2039	0	0	891		344	891	2582	258	1090	3930	3039		0	0	0	0	286	0		2005	275	2420	2477	19328	
2039 - 2040	0	0	954		344	954	2608	261	1122	3991	3037		0	0	0	0	286	0		1719	241	2453	2510	21838	
2040 - 2041	0	0	1021		344	1021	3032	303	1156	4491	3470		0	0	0	0	286	0		1432	206	2920	2977	24816	
2041 - 2042	0	0	1094		344	1094	3062	306	1191	4559	3465		0	0	0	0	286	0		1146	172	2949	3006	27822	
2042 - 2043	0	0	1172		344	1172	3548	355	1226	5129	3957		0	0	0	0	286	0		859	137	3476	3533	31355	
2043 - 2044	0	0	1256		395	1692	2948	358	1263	5205	2257		0	0	0	0	286	0		573	103	3451	1868	33223	
2044 - 2045	0	0	1347		441	1545	2892	416	1301	5877	2985		0	0	0	0	286	0		286	69	4020	2630	35853	
2045 - 2046	0	0	1445		441	0	1445	4202	420	1340	5962	4517		0	0	0	286	0		0	34	4042	4196	40049	
	10700	716	17545		8934	3237	32198	48784	4878	24674	78336	12.85%	4869			5832	6010	134	44	10780	41077	40049			
											46138														

PUNE METRO PROJECT				I		II												Rate		Loan %		Upfront Fee		Table 11.14	
CAPITAL COST-FIXED				9221		6072		3149										Market Borrowings		12.00%		4.00%		0.20%	
CAPITAL COST - CURRENT				10700		7071		3629										JICA Loan		1.40%		96.00%		0.00%	
DOMESTIC FUNDING - BASE CASE																									
Year	Completion Cost	Additional Capital	Running Expenses	Depreciation	Replacement Cost	Total Cost	Fare box Revenue	PD & ADVT.	Additional revenue from Dev Charges & Registration	Total Revenue	Net Cash Flow for IRR	Equity from GOI & GOM	Availability of cash	Cumulative cash	Cum. Loan	Loan	Repayment of Loan	IDC on JICA Loan	IDC on MB	Cumulative loan incl. IDC	Interest	Profit before Tax	Cash Balance	Cumulative Cash	
1	2	3	4	5	6	7	8	9	10	11	12	13	14	15	16	17	18	19	20	21	22	23	24	25	
2016 - 2017	509					509				0	-509	440	-70	-70	70	70	0	12	0	82					
2017 - 2018	1643					1643				0	-1643	1073	-570	-640	640	570	0	5	2	659					
2018 - 2019	2518					2518				0	-2518	1072	-1446	-2086	2086	1446	0	18	7	2130					
2019 - 2020	2448					2448				0	-2448	762	-1686	-3772	3772	1686	0	39	14	3869					
2020 - 2021	2126		91		216	2217	188	19	640	847	-1370	762	-1364	-5136	5136	1364	0	60	21	5314	0	540	756	756	
2021 - 2022	1080		252		325	1332	563	-106	659	1116	-216	760	-320	-5456	5456	320	0	0	0	5634	638	-98	227	983	
2022 - 2023	376		269		325	645	665	-68	679	1276	631	0	-376	-5832	5832	376	0	0	0	6010	676	6	331	1314	
2023 - 2024	0	464	300		339	764	678	-33	699	1344	580		0	0	0	0	28	0	0	5981	721	-16	-169	1145	
2024 - 2025	0	0	320		339	320	789	38	720	1547	1227		0	0	0	0	28	0	0	5953	718	171	482	1626	
2025 - 2026	0	0	341		339	341	804	202	742	1748	1407		0	0	0	0	28	0	0	5925	714	354	664	2291	
2026 - 2027	0	0	364		339	364	943	239	764	1946	1582		0	0	0	0	315	0	0	5611	711	532	557	2847	
2027 - 2028	0	0	389		339	389	960	264	787	2011	1622		0	0	0	0	315	0	0	5296	673	610	634	3482	
2028 - 2029	0	0	415		339	415	1130	304	811	2245	1830		0	0	0	0	315	0	0	4982	636	855	880	4361	
2029 - 2030	0	0	444		339	444	1152	331	835	2318	1874		0	0	0	0	315	0	0	4667	598	937	962	5323	
2030 - 2031	0	0	474		339	474	1350	380	860	2590	2116		0	0	0	0	315	0	0	4353	560	1217	1242	6565	
2031 - 2032	0	0	507		339	507	1375	490	886	2751	2244		0	0	0	0	315	0	0	4038	522	1383	1407	7972	
2032 - 2033	0	0	542		339	542	1595	530	912	3037	2495		0	0	0	0	315	0	0	3724	485	1672	1696	9668	
2033 - 2034	0	252	637		347	889	1611	550	940	3101	2212		0	0	0	0	286	0	0	3437	447	1670	1479	11147	
2034 - 2035	0	0	681		347	681	1879	596	968	3443	2762		0	0	0	0	286	0	0	3151	412	2003	2063	13210	
2035 - 2036	0	0	728		347	728	1898	619	997	3514	2786		0	0	0	0	286	0	0	2865	378	2061	2122	15331	
2036 - 2037	0	0	778		347	778	2202	670	1027	3899	3121		0	0	0	0	286	0	0	2578	344	2430	2491	17822	
2037 - 2038	0	0	833		347	833	2224	694	1058	3976	3143		0	0	0	0	286	0	0	2292	309	2486	2547	20369	
2038 - 2039	0	0	891		347	891	2582	753	1090	4425	3534		0	0	0	0	286	0	0	2005	275	2912	2972	23341	
2039 - 2040	0	0	954		347	954	2608	781	1122	4511	3557		0	0	0	0	286	0	0	1719	241	2970	3030	26371	
2040 - 2041	0	0	1021		347	1021	3032	849	1156	5037	4016		0	0	0	0	286	0	0	1432	206	3463	3523	29895	
2041 - 2042	0	0	1094		347	1094	3062	880	1191	5133	4039		0	0	0	0	286	0	0	1146	172	3520	3580	33475	
2042 - 2043	0	0	1172		347	1172	3548	958	1226	5732	4560		0	0	0	0	286	0	0	859	137	4076	4136	37611	
2043 - 2044	0	0	1256		398	1692	2948	3584	990	1263	5837	2889		0	0	0	286	0	0	573	103	4080	2500	40111	
2044 - 2045	0	0	1347		444	1545	2892	4160	1079	1301	6540	3648		0	0	0	286	0	0	286	69	4680	3293	43404	
2045 - 2046	0	0	1445		444	0	1445	4202	1117	1340	6659	5214		0	0	0	286	0	0	0	34	4736	4893	48297	
	10700	716	17545		9012	32198	48784	13126	24674	86584	13.60%	4869				5832	6010	134	44		10780	49247	48297		
											54386														

PUNE METRO PROJECT				I		II														Rate	Loan %	Upfront Fee	Table 11.14							
CAPITAL COST-FIXED		9221		6072		3149														12.00%	100.00%	0.20%								
CAPITAL COST - CURRENT		10700		7071		3629														1.40%	0.00%	0.00%								
DOMESTIC FUNDING - BASE CASE																														
Year	Completion Cost	Additional Capital	Running Expenses	Depreciation	Replacement Cost	Total Cost	Fare box Revenue	Revenue From advertisement, Kiosk etc.	Income From Property Development	Additional revenue from Dev Charges & Registration	Total Revenue	Net Cash Flow for IRR	Equity from GOI & GOM	Availability of cash	Cumulative cash	Cum. Loan	Loan	Repayment of Loan	IDC on JICA Loan	IDC on MB	Cumulative loan incl. IDC	Interest	Profit before Tax	Cash Balance	Cumulative Cash					
1	2	3	4	5	6	7	8	9	10	11	12	13	14	15	16	17	18	19	20	21	22	23	24	25	26					
2016 - 2017	509					509					0	-509	440	-70	-70	70	70	0	11	4	85									
2017 - 2018	1643					1643					0	-1643	1073	-570	-640	640	570	0	0	43	698									
2018 - 2019	2518					2518					0	-2518	1072	-1446	-2086	2086	1446	0	0	164	2308									
2019 - 2020	2448					2448					0	-2448	762	-1686	-3772	3772	1686	0	0	351	4345									
2020 - 2021	2126		91		212	2217	188	19	0	640	847	-1370	762	-1364	-5136	5136	1364	0	0	534	6243	521	23	235	235					
2021 - 2022	1080		252		321	1332	563	56	-162	659	1116	-216	760	-320	-5456	5456	320	0	0		6563	749	-206	115	350					
2022 - 2023	376		269		321	645	665	67	-135	679	1276	631	0	-376	-5832	5832	376	0	0		6939	788	-102	219	569					
2023 - 2024	0	464	300		335	764	678	68	-101	699	1344	580		0	0	0	0	133	0		6805	833	-123	-386	184					
2024 - 2025	0	0	320		335	320	789	79	-41	720	1547	1227		0	0	0	0	133	0		6672	817	76	277	461					
2025 - 2026	0	0	341		335	341	804	80	122	742	1748	1407		0	0	0	0	133	0		6539	801	271	473	934					
2026 - 2027	0	0	364		335	364	943	94	145	764	1946	1582		0	0	0	0	414	0		6125	785	463	384	1318					
2027 - 2028	0	0	389		335	389	960	96	168	787	2011	1622		0	0	0	0	414	0		5712	735	552	474	1792					
2028 - 2029	0	0	415		335	415	1130	113	191	811	2245	1830		0	0	0	0	414	0		5298	685	809	731	2523					
2029 - 2030	0	0	444		335	444	1152	115	216	835	2318	1874		0	0	0	0	414	0		4885	636	903	825	3347					
2030 - 2031	0	0	474		335	474	1350	135	245	860	2590	2116		0	0	0	0	414	0		4471	586	1195	1116	4464					
2031 - 2032	0	0	507		335	507	1375	138	352	886	2751	2244		0	0	0	0	414	0		4057	537	1372	1294	5758					
2032 - 2033	0	0	542		335	542	1595	160	370	912	3037	2495		0	0	0	0	414	0		3644	487	1674	1595	7353					
2033 - 2034	0	252	637		343	889	1611	161	389	940	3101	2212		0	0	0	0	280	0		3364	437	1684	1494	8847					
2034 - 2035	0	0	681		343	681	1879	188	408	968	3443	2762		0	0	0	0	280	0		3083	404	2015	2078	10925					
2035 - 2036	0	0	728		343	728	1898	190	429	997	3514	2786		0	0	0	0	280	0		2803	370	2073	2136	13061					
2036 - 2037	0	0	778		343	778	2202	220	450	1027	3899	3121		0	0	0	0	280	0		2523	336	2442	2504	15565					
2037 - 2038	0	0	833		343	833	2224	222	472	1058	3976	3143		0	0	0	0	280	0		2242	303	2497	2560	18125					
2038 - 2039	0	0	891		343	891	2582	258	495	1090	4425	3534		0	0	0	0	280	0		1962	269	2921	2984	21109					
2039 - 2040	0	0	954		343	954	2608	261	520	1122	4511	3557		0	0	0	0	280	0		1682	235	2979	3041	24151					
2040 - 2041	0	0	1021		343	1021	3032	303	546	1156	5037	4016		0	0	0	0	280	0		1402	202	3471	3534	27684					
2041 - 2042	0	0	1094		343	1094	3062	306	574	1191	5133	4039		0	0	0	0	280	0		1121	168	3527	3590	31274					
2042 - 2043	0	0	1172		343	1172	3548	355	603	1226	5732	4560		0	0	0	0	280	0		841	135	4083	4145	35420					
2043 - 2044	0	0	1256		394	1692	2948	3584	632	1263	5837	2889		0	0	0	0	280	0		561	101	4086	2508	37928					
2044 - 2045	0	0	1347		440	1545	2892	4160	416	663	1301	6540	3648		0	0	0	280	0		280	67	4686	3300	41228					
2045 - 2046	0	0	1445		440	0	1445	4202	420	697	1340	6659	5214		0	0	0	280	0		0	34	4740	4900	46128					
		10700	716	17545	8908	3237	32198	48784	4878	8248	24674	86584	4869				5832	6939	11	1096		12019	48112	46128						
												54386																		

PUNE METRO PROJECT																							Table 11.16	
CAPITAL COST-FIXED																			12.00%					
CAPITAL COST - CURRENT																			3768					
DOMESTIC FUNDING - BASE CASE																								
Year	Completion Cost	Additional Capital	Running Expenses	Depreciation	Replacement Cost	Total Cost	Fare box Revenue	PD & Advertisement	Total Revenue	Net Cash Flow for IRR	Concessioner Equity	Availability of cash	Cumulative cash	Cum. Loan	Loan	Repayment of Loan	IDC	Cumulative loan incl. IDC	Interest	Profit before Tax	Cash Balance	Cumulative Cash	Return on Equity (EIRR) Pre-Tax	
1	2	3	4	5	6	7	8	9	10	11	12	13	14	15	16	17	18	19	20	21	22	23	24	
2016 - 2017	48					48			0	-48	314	266	266	0	0	0	0	0			0	0	-314	
2017 - 2018	832					832			0	-832	314	-518	-252	252	252	0	15	267			0	0	-314	
2018 - 2019	908					908			0	-908	314	-594	-846	846	594	0	66	927			0	0	-314	
2019 - 2020	1048					1048			0	-1048	314	-734	-1580	1580	734	0	146	1807			0	0	-314	
2020 - 2021	326		91	126		417	188	19	207	-210	0	-326	-1906	1906	326	0	209	2342	0	-10	116	116	116	
2021 - 2022	230		252	126		482	563	-106	457	-25	0	-230	-2136	2136	230	0		2572	281	-202	-76	40	-76	
2022 - 2023	376		269	126		645	665	-68	597	-48		-376	-2512	2512	376	0		2948	309	-107	19	59	19	
2023 - 2024	0	464	300	140		764	678	-33	645	-119		0	0	0	0	295		2653	354	-149	-768	-708	-768	
2024 - 2025	0	0	320	140		320	789	38	827	507		0	0	0	0	295		2358	318	49	-106	-814	-106	
2025 - 2026	0	0	341	140		341	804	202	1006	665		0	0	0	0	295		2064	283	242	87	-727	87	
2026 - 2027	0	0	364	140		364	943	239	1182	818		0	0	0	0	295		1769	248	430	276	-452	276	
2027 - 2028	0	0	389	140		389	960	264	1224	835		0	0	0	0	295		1474	212	483	328	-124	328	
2028 - 2029	0	0	415	140		415	1130	304	1434	1019		0	0	0	0	295		1179	177	702	547	424	547	
2029 - 2030	0	0	444	140		444	1152	331	1483	1039		0	0	0	0	295		884	142	757	603	1026	603	
2030 - 2031	0	0	474	140		474	1350	380	1730	1256		0	0	0	0	295		590	106	1010	855	1881	855	
2031 - 2032	0	0	507	140		507	1375	490	1865	1358		0	0	0	0	295		295	71	1147	992	2874	992	
2032 - 2033	0	0	542	140		542	1595	530	2125	1583		0	0	0	0	295		0	35	1408	1253	4127	1253	
2033 - 2034	0	252	637	148		889	1611	550	2161	1272		0	0	0	0	0		0	0	1376	1272	5399	1272	
2034 - 2035	0	0	681	148		681	1879	596	2475	1794		0	0	0	0	0		0	0	1646	1794	7193	1794	
2035 - 2036	0	0	728	148		728	1898	619	2517	1789		0	0	0	0	0		0	0	1641	1789	8982	1789	
2036 - 2037	0	0	778	148		778	2202	670	2872	2094		0	0	0	0	0		0	0	1946	2094	11076	2094	
2037 - 2038	0	0	833	148		833	2224	694	2918	2085		0	0	0	0	0		0	0	1937	2085	13161	2085	
2038 - 2039	0	0	891	148		891	2582	753	3335	2444		0	0	0	0	0		0	0	2296	2444	15605	2444	
2039 - 2040	0	0	954	148		954	2608	781	3389	2435		0	0	0	0	0		0	0	2287	2435	18040	2435	
2040 - 2041	0	0	1021	148		1021	3032	849	3881	2860		0	0	0	0	0		0	0	2712	2860	20900	2860	
2041 - 2042	0	0	1094	148		1094	3062	880	3942	2848		0	0	0	0	0		0	0	2700	2848	23748	2848	
2042 - 2043	0	0	1172	148		1172	3548	958	4506	3334		0	0	0	0	0		0	0	3186	3334	27082	3334	
2043 - 2044	0	0	1256	199	1692	2948	3584	990	4574	1626		0	0	0	0	0		0	0	3119	1626	28708	1626	
2044 - 2045	0	0	1347	245	1545	2892	4160	1079	5239	2347		0	0	0	0	0		0	0	3647	2347	31055	2347	
2045 - 2046	0	0	1445	245	0	1445	4202	1117	5319	3874		0	0	0	0	0		0	0	3629	3874	34929	3874	
	3768	716	17545	3947	3237	25266	48784	13126	61910	16.69%	1256				2512	2948	436		2535	37883	34929		18.10%	
										36644														

Chapter - 13

Economic Appraisal



- 13.1 Introduction
- 13.2 Values Adopted for Some Important Variables
- 13.3 Economic Benefit Stream
- 13.4 Metro Construction Cost
- 13.5 Economic Performance Indicators
- 13.6 Sensitivity Analysis
- 13.7 Quantified Benefits
- 13.8 Transport Oriented Development (TOD) & EIRR



CHAPTER - 13

ECONOMIC APPRAISAL

13.1 INTRODUCTION

Economic appraisal of a project starts from quantification of measurable economic benefits in economic money values, which are basically the savings of resource cost due to introduction of the metro line. Economic savings are derived from the difference of the cost of the same benefit components under 'with' and 'without' metro line. Total net savings/or benefit is obtained by subtracting the economic cost of the project (incurred for construction (Capital) and maintenance (recurring) costs for the metro line) from the benefits out of the project in each year. The net benefit value which would be negative during initial years becomes positive as years pass. Internal rate of return and benefit cost ratio are derived from the stream

The sources from where economic savings occur are identified first. Although there are many kinds of primary, secondary and tertiary benefits, only the quantifiable components can be taken to measure the benefits. These components are quantified by linking with the number of passengers shifted and the passenger km saved by the trips which are shifted from road/rail based modes to metro. It may be observed that first four benefit components given in Table 10.1 are direct benefits due to shifting of trips to metro, but other benefit components are due to decongestion effect on the road. Benefit components were first estimated applying market values then were converted into respective economic values by using separate economic factors which are also given in table 13.1. Depending upon methodology of estimation, economic factors are assumed. Overall economic value of benefit components is 92.25% of the market value. Similarly economic value of the cost components are 82.50% of the market cost.

Table 13.1 -Benefit Components Due To Metro

S. No	Benefit Components	Economic Factors
1	Annual Time Cost Saved by Metro Passengers in Cr. Rs.	100%
2	Annual Fuel Cost Saved by Metro Passengers in Cr. Rs.	86%
3	Annual Vehicle Operating Cost Saved by Metro Passengers in Cr. Rs.	86%
4	Emission Saving Cost in Cr. Rs.	90%
5	Accident Cost in Cr. Rs.	100%
6	Annual Time Cost Saved by Road Passengers in Cr. Rs.	90%
7	Annual Fuel Cost Saved by Road Passengers in Cr. Rs.	86%
8	Annual Infra Structure Maintenance Cost	100%

13.2 VALUES ADOPTED FOR SOME IMPORTANT VARIABLES

Benefit components are converted (by applying appropriate unit cost) to money values (Rs.). Derivation procedures of some of the values used for economic analysis are shown in **Table 13.2**.

Table 13.2 -Values Adopted For Some Important Variables

S. No	Values	Important variables
1	Rs. 1.12/min (2020)	Time Cost derived from Households monthly income level.
2	Market Rate (2015)	Fuel Cost (value of Petrol, Diesel and CNG).
3	Table 13.3	Vehicle Operating Cost (Derived from Life Cycle Cost of different passenger vehicles per km)
4	Table 13.4	Emission (gm/km as per CPCB and UK Norms) Emission Saving Cost (adopted for Indian conditions in Rs/ton).
5	Table 13.5	Accident Rate (No of fatal and all accidents per one Cr.KM). Accident costs are derived from published papers at current rate.
6	46.61%	Passenger km – Vehicle km conversion factor and mode share percent values (derived from fresh traffic volume count and modal split seen in Home Interview study) .
7	Road User Cost Study Model	Fuel Consumption of vehicles at a given speed is derived
8	Rs. 1.0/vehicle km	Infra Structure Maintenance Cost is derived from published values on annual expenditure on roads and traffic and annual vehicle km

Table 13.3 - Vehicle Operating Cost in Rs.

Per Vehicle KM	Bus	4 Wh (Large)	4 Wh (Small)	2 Wh (MC)	2 Wh (SC)	3 Wh (Auto)	Mini Bus
Maintenance Cost	3.94	3.31	2.01	0.57	0.72	2.25	2.75
Capital Cost	2.40	2.67	1.20	0.18	0.16	0.72	1.72
Total VOC	6.98	6.58	3.54	0.82	0.96	3.27	4.92

Table 13.4 - Vehicle Emission 2011-2021(CPCB) and Cost in Rs.

VEHICLE	CO	HC	NOX	PM	CO	CO2
BUS	3.72	0.16	6.53	0.24	3.72	787.72
2W-2 STROKE	1.4	1.32	0.08	0.05	1.4	24.99
2W-4 STROKE	1.4	0.7	0.3	0.05	1.4	28.58
MINI BUS	2.48	0.83	8.26	0.58	2.48	358.98
4W-SMALL	1.39	0.15	0.12	0.02	1.39	139.51
4W-LARGE	0.58	0.05	0.45	0.05	0.58	156.55
TATA MAGIC	1.24	0.17	0.58	0.17	1.24	160
3W	2.45	0.75	0.12	0.08	2.45	77.89
Cost	RS. 100000 PER TON					500

Table 13.5 - Accident Rate^s and Cost in Rs

Accident Rate in the year 2016	Accident Rate perCr. Vehicle KM	Accident Cost in Rs
Average of all types.	1.58	593009
Fatal Accident.	0.20	1704425

Traffic parameter values used for economic analysis are given in **Table 13.6**.

Table 13.6 -Traffic Parameter Values

TRAFFIC INPUT	2020	2021	2026	2031
SECTION LENGTH km	16.589	31.254	31.254	31.254
PASSKM/KM=	61487	135596	135795	145886
PASKM=	1020000	4237927	4244131	4559518
TRIP LENGTH km=	5.00	6.96	6.94	6.21
PASSENGER	204000	609020	611304	734364

13.3 ECONOMIC BENEFIT STREAM

Benefits in terms of money value are estimated directly from the projected passenger km saved for the horizon years (2021, 2026 and 2031) and values for other years are interpolated on the basis of projected traffic. Market values are used for calculating costs and then appropriate economic factors (see table 13.1) are applied. For each year values of each benefit components are obtained and thus benefit stream is estimated. Benefit Components Stream for **Pune Metro Rail** is shown in **Table 13.7**.

Table 13.7 -Year wise Economic Values of Benefit Components (Stream)

Year	Year	Annual Time Cost Saved by Metro Passengers in Cr. Rs.	Annual Fuel Cost Saved by Metro Passengers in Cr. Rs.	Annual Vehicle Operating Cost Saved by Metro Passengers in Cr. Rs.	Emission Saving Cost in Cr. Rs.	Accident Cost in Cr. Rs.	Annual Time Cost Saved by Road Passengers in Cr. Rs.	Annual Fuel Cost Saved by Road Passengers in Cr. Rs.	Annual Infra Structure Maintenance Cost in Cr. Rs.	Total Benefits without Discount in Cr. Rs.
2021	2022	152.95	194.67	77.27	4.72	2.45	5.87	1.17	18.22	457.31
2022	2023	500.12	811.75	345.10	21.07	10.95	26.74	5.58	81.38	1802.68
2023	2024	558.14	821.08	373.71	22.81	11.85	29.55	6.35	88.12	1911.61
2024	2025	622.88	830.94	404.69	21.18	12.84	32.65	7.12	95.43	2027.72
2025	2026	695.13	841.35	438.23	19.12	13.90	36.08	7.90	103.34	2155.04
2026	2027	775.77	852.30	474.56	20.70	15.05	39.87	8.67	111.90	2298.82
2027	2028	865.76	863.80	513.89	22.42	16.30	44.05	9.45	121.18	2456.85
2028	2029	966.19	875.85	556.49	24.27	17.65	48.68	10.24	131.22	2630.60
2029	2030	1078.27	852.30	602.62	26.29	19.11	53.79	11.03	142.10	2785.50
2030	2031	1203.35	863.80	652.57	28.47	20.70	59.44	11.82	153.88	2994.02
2031	2032	1342.93	875.85	706.67	30.82	22.41	65.68	12.62	166.63	3223.63
2032	2033	1498.72	929.78	765.24	33.38	24.27	72.57	13.43	180.45	3517.84
2033	2034	1643.48	947.21	830.86	36.24	26.35	80.40	14.28	195.92	3774.74
2034	2035	1802.22	1011.31	945.05	41.22	28.61	95.69	15.87	222.84	4162.81
2035	2036	1976.29	1031.03	1026.08	44.76	31.07	106.01	16.79	241.95	4473.99
2036	2037	2167.18	1051.52	1114.06	48.60	33.73	117.45	17.73	262.70	4812.96
2037	2038	2406.56	1071.23	1211.42	51.68	36.55	130.57	19.26	285.66	5212.93
2038	2039	2672.37	1091.32	1317.30	54.96	39.61	145.15	20.92	310.62	5652.26
2039	2040	2967.55	1111.78	1432.43	58.45	42.93	161.36	22.73	337.77	6135.00
2040	2041	3295.33	1132.62	1557.63	62.16	46.52	179.38	24.69	367.29	6665.62
2041	2042	3659.31	1153.86	1693.76	66.11	50.42	199.42	26.82	399.39	7249.09
2042	2043	4063.50	1175.49	1841.79	70.30	54.64	221.69	29.14	434.30	7890.85
2043	2044	4512.33	1197.53	2002.76	74.77	59.21	246.45	31.66	472.26	8596.96
2044	2045	5010.74	1219.98	2177.80	79.51	64.17	273.98	34.39	513.53	9374.10
2045	2046	5564.19	1242.85	2368.14	84.56	69.54	304.58	37.36	558.41	10229.64
2046	2047	6178.78	1266.16	2575.11	89.93	75.36	338.60	40.58	607.22	11171.74

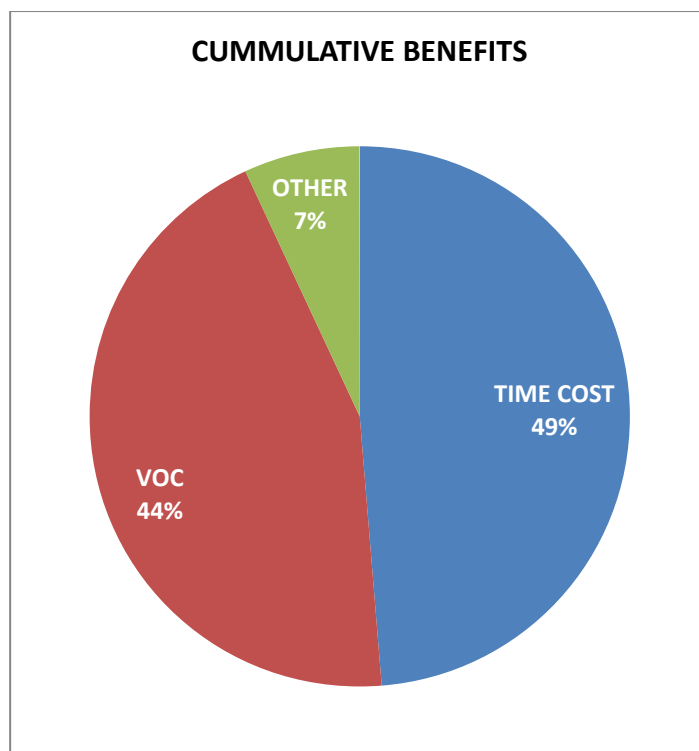


Figure 13.1 - Percent of Benefits

Accrued Benefit components for the lifecycle period (2021-2047) are shown in figure 10.1 which shows benefits are mainly coming from saving of travel time (49%), VOC (including fuel) (44%). Other combined benefits are 7%. In this area, personalised modes (car and two wheelers) are dominant which have made vehicle by passenger ratio very high (46.61%). Average modal split obtained from the Home Interview survey shows that 90.15% vehicle trips are by private modes as may be seen in table 13.8. Obviously presence of dependable mass transport system is not there.

Table 13.8 -Average Modal Split In Study Area

Vehicles	% PASS	% Vehicle
Car-small	5.27%	3.89%
Car-large	4.32%	2.86%
Bus	11.42%	0.78%
Mini bus	7.61%	0.98%
RTV	2.53%	1.35%
2 whs	58.75%	80.81%
Auto Ricksha	10.11%	9.35%

13.4 METRO CONSTRUCTION COST

Total cost of metro construction (CAPITAL COST) is derived after considering cost of all major component such as Relocation and Rehabilitation(RR), Civil construction for underground and elevated portions, Stations and Depots, Track laying, Signalling and telecommunication, Power traction line, Rolling stock, Man power etc. RUCURRING COST includes energy cost, maintenance cost, and operation cost. Economic analysis period is taken from 2016-17 to 2045-46 out of which 9 years are marked as payment period. It is assumed that revenue year will start in 2020-21. Additional capital intensive costs may occur in the years 2031-32, 2041-42-43. Completion cost is obtained from the fixed cost estimated (year 2015) for the material and the work to be done by applying annual escalation factor of 7.5%. Economic cost is obtained from the fixed cost by removing tax components. Tax details are given in the finance chapter. Thus cost streams are generated as shown in Table 13.9.

**Table 13.9 - Estimated Capital and Recurring Cost
(Including Central Tax)**

		Current Cost		Economic Cost	
Year	Year	Capital Cost	Recurring Cost	Capital Cost	Recurring Cost
Beginning	Ending	Cr. Rs.	Cr. Rs	Cr. Rs.	Cr. Rs
2016	2017	511	0	445	0
2017	2018	1688	0	1370	0
2018	2019	2647	0	2002	0
2019	2020	2653	0	1826	0
2020	2021	2359	100	1511	65
2021	2022	1227	282	731	169
2022	2023	437	305	242	169
2023	2024	464	345	239	177
2024	2025	0	373	0	178
2025	2026	0	403	0	178
2026	2027	0	436	0	178
2027	2028	0	471	0	178
2028	2029	0	509	0	178
2029	2030	0	550	0	178

2030	2031	0	594	0	178
2031	2032	0	642	0	178
2032	2033	0	694	0	179
2033	2034	252	835	60	199
2034	2035	0	903	0	199
2035	2036	0	975	0	199
2036	2037	0	1054	0	199
2037	2038	0	1138	0	199
2038	2039	0	1230	0	199
2039	2040	0	1329	0	199
2040	2041	0	1437	0	200
2041	2042	0	1552	0	200
2042	2043	0	1678	0	200
2043	2044	3270	1813	361	200
2044	2045	3056	1960	312	200
2045	2046	0	2119	0	200

13.5 ECONOMIC PERFORMANCE INDICATORS

After generating the cost and benefit stream table, values of economic indicators are derived and are presented in table 13.10. Project period is 2016-2047, EIRR at present rate is found to be **16.32%** and B/C ratio as 3.24 and with 12 % discount, EIRR is 3.85% and B/C ratio is 1.41. EIRR (fixed cost excluding all taxes-economic value) is found to be 21.53% and B/C ratio as 9.73 and with 12 % discount, EIRR is 8.51% and B/C ratio is 2.34.

Table 13.10 -Economic Indicator Values(with Central Tax)

PUNE	Current Cost Basis		Economic Cost Basis	
	Without discount	With discount (12%)	Without discount	With discount (12%)
Full Metro Network				
Cumulative cost	34761	10018	11557	6030
Cumulative benefit	112493	14139	112493	14139
Benefit Cost Ratio	3.24	1.41	9.73	2.34
NPV	77732	4120	100936	8109
EIRR	16.32%	3.85%	21.53%	8.51%

13.6 SENSITIVITY ANALYSIS

Sensitivity of EIRR and B/C ratios both with and without discount was carried out and the output is given in the **Table 13.11**. 2046-47 is taken for the year of comparison. It is seen that in worst case, when construction cost is increased by 20% and traffic is decreased by 20%, EIRR and B/C is goes beyond the limit of acceptance.

Table 13.11- Sensitivity of EIRR

SENSITIVITY		WITHOUT DISCOUNT			WITH DISCOUNT		
TRAFFIC	COST	EIRR	B/C	COST	EIRR	B/C	COST
0%	0%	16.32%	3.24	34761	3.85%	1.41	10018
-10%	0%	15.81%	3.09	34761	3.40%	1.35	10018
-20%	0%	15.28%	2.94	34761	2.93%	1.30	10018
0%	10%	15.10%	2.94	38237	2.77%	1.28	11020
0%	20%	14.00%	2.70	41713	1.79%	1.18	12022
-10%	10%	14.60%	2.81	38237	2.32%	1.23	11020
-20%	20%	12.98%	2.45	41713	0.87%	1.08	12022

13.7 QUANTIFIED BENEFITS.

Quantified values of the benefits (first five years) are shown in table 13.12 and 13.13 which forms the basis of economic analysis.

Table 13.12 Quantified Benefits in Horizon Years

Annual Values	2021	2022	2023	2024	2025
Time Saved by Metro Passengers in Cr. Hr.	6.92	7.19	7.46	7.75	8.04
Fuel Saved by Metro Passengers in thousand Tons.	122.25	123.79	125.40	127.10	128.88
Daily vehicles reduced (off the road)	61857	62311	62769	63229	63694
CO2 reduced in thousand tons	30.53	30.76	30.98	31.21	31.44
Other gases reduced in thousand tons	1.87	1.89	1.61	1.32	1.33
Reduced No of Fatal Accidents	15	15	15	15	16
Reduced No of Other Accidents	104	105	106	107	108
Annual Vehicle km Reduced in Thousand Km.	20.74	20.89	21.04	21.20	21.36

Table 13.13 Quantified Environmental Benefits in Horizon Years

Environmental Parameters	2021	2022	2023	2024	2025
CO (Thousand Tonnes)	1069	1077	890	700	705
HC (")	490	493	405	316	318
NOX(")	276	278	276	274	276
PM(")	36	36	34	32	32
SO2(")	2	2	2	2	2
CO2(")	30533	30757	30983	31210	31439
Total Emission Saved(")	32405	32643	32590	32533	32772
All Accident Saved	120	120	121	122	123
Fatal Accident Saved	15	15	15	15	16

Chapter - 14

Implementation Plan



- 14.1 Way Forward For Implementing Pune Metro Project
- 14.2 Institutional Arrangements
- 14.3 Contracts
- 14.4 Organisational Set-up of PMRC
- 14.5 Legal Framework
- 14.6 Concessions from Government
- 14.7 Posting of OSD
- 14.8 Need for Dedicated Fund for Metro Projects



CHAPTER - 14

IMPLEMENTATION PLAN

14.1 WAY FORWARD FOR IMPLEMENTING PUNE METRO PROJECT

On receipt of the Detailed Project Report, following action will be required for implementing the Corridor-1 & Corridor-2 of Pune Metro:

- Approval to the Detailed Project Report to be taken from Maharashtra State Government (Cabinet approval).
- The DPR to be forwarded to the Ministry of Urban Development, Planning Commission and Finance Ministry with the request for approving the Metro project and for financial participation through equity contribution in the SPV.
- Signing of an MOU between Maharashtra State Government and Government of India giving all details of the Joint Venture bringing out the financial involvement of each party, liability for the loans raised, the administrative control in the SPV, policy in regard to fare structure, operational subsidy, if any, etc.
- Set up a Special Purpose Vehicle (SPV) for implementing the project and for its subsequent Operation & Maintenance.
- The Government of India is considering enactment of a Central legislation to give legal cover for construction and maintenance of Metros in other cities. Under this Central enactment State Governments will have to frame the rules and procedures for implementation.
- The State Government should formulate the funding plan for executing this project and get the same approved by the Government of India. The loan portion of the funding will have to be tied up by State Government in consultation with the Government of India.
- The Government should freeze all developments along the corridors suggested. For any constructions within 50 m. of the proposed alignment a system of No Objection Certificate should be introduced so that infructuous expenditure at a later stage is avoided.

14.2 INSTITUTIONAL ARRANGEMENTS

To enable Pune Metro project to be implemented without any loss of time and cost over-run, effective institutional arrangements would need to be set up. Details of these arrangements are explained below:

14.2.1 Special Purpose Vehicle

Experience of implementing Delhi Metro project has shown that a Special Purpose Vehicle (SPV), vested with adequate powers, is an effective organizational arrangement to implement and subsequently operate and maintain a metro project. An SPV should, therefore, be set up for Pune Metro and registered under the Companies Act, 1956. This SPV should be a PSU of the State Government and may be named as 'Pune Mahanagar Metro Rail Corporation Ltd.' (PMMRC). Since the equity for the project will be contributed by the State and the Central Governments, both these Governments should have Directors on its Board. The number of Directors from each Government can be mutually agreed upon between the Central and the State Governments. The Managing Director of PMMRC should be the nominee of the State Government. In order to avoid delays usually associated with bureaucratic process of decision-making, the Board of Directors (BOD) of PMMRC should be vested with full powers needed to implement the project. The BOD, in turn, should delegate adequate powers to the Managing Director to take all decisions in day-to-day matters. The Managing Director should be a technocrat of proven record and impeccable integrity. A Railway background would be an added advantage. A metro background would be most desirable.

14.2.2 Implementation Through SPV

Once the SPV is formed, it has to take action for appointment of General Consultants for project management including preparation of tender documents. Till the General Consultants are in position, PMMRC should appoint an interim Consultant for all preliminary and enabling jobs such as land acquisition, detailed design of civil structures, utility diversions, etc.

A suggested project implementation schedule is given below. The proposed date of commissioning of the section with suggested dates of important milestones is given in **Table 14.1**.

Table 14.1 -Implementation Schedule through SPV

S. No.	Item of Work	Completion Time(days)
1.	Submission of Final DPR to State Govt.	D
2	Approval of DPR by State Government	D+30
3	Appoint interim Consultant for preliminary works	D+30
4	Approval of Project by Empowered Committee	D+60
5	Sanction of Project by EGOM.	D+90
6	Appoint General Consultant	D+270
7	Tendering, Execution of works and Procurement of equipments, coaches and installations	D+300 to D+1600
89	Testing and Commissioning	D+1600 to D+1700
9	Revenue Operation	D+1700

Both corridors can be divided into sections for the purpose of commercial opening in stages. In first stage, line No. 2 (completely elevated) and elevated portion of Corridor 1 up to Shivaji Nagar Station (Underground) will be opened. Both Depots should also be available for commercial operation.

14.3 CONTRACTS

14.3.1 Civil Works

Elevated viaduct will be part design and built basis while the elevated stations will be constructed on design and built basis. Underground section will be constructed based on the design and built basis. Corridor I will have two packages for the elevated viaduct and two packages for the elevated stations. The underground stretch of corridor – 1 will be implemented in two packages ie. One package will have the cut and cover portion and Shivaji Nagar, Swargate stations.

Architectural finishes, fire fighting arrangements and general electrification, will form part of civil contracts.

14.3.2 System Contracts

- Design, construct and installation for Traction and Power Supply.
- Design, construct and installation of Signal and Telecommunication works.
- Design, construct and installation of lifts.
- Design, construct and installation of escalators.

- Design, construct and commissioning of Automatic Fare Collection System.
- Design and supply of rolling stock.
- Installation of track in Depot and on main line.
- Design and installation of Signages.

14.3.3 Depot Contracts

The contracts are required for Civil and E&M works at Agriculture University and Kothrud Depot.

Supply of Depot Equipment, the number of contracts may be decided as and when the work is in progress.

14.4 ORGANISATIONAL SET-UP OF PMMRC

The PMMRC Organisation, as stated earlier, should be very lean but effective. It will consist of a non-executive Chairman, a Managing Director with full Executive Powers (in Schedule 'A') and three Functional Directors (in Schedule 'B') including Director (Finance). All the three Functional Directors will be full members of the Management Board. The Directors will be assisted by Heads of Departments in each of the major disciplines and they in turn will have Deputy Heads of Departments. The organisation should be basically officer-oriented with only Personal Assistants and Technical Assistants attached to senior officers by eliminating unproductive layers of staff such as Peons, Clerks, etc. We strongly recommend that the total organizational strength is limited to 45 to 50 eliminating too many tiers to enable faster decision-making. An organizational chart for PMMRC is enclosed.

It is necessary for the PMMRC officers to get exposed to the Metro technology and Metro culture through study tours of some of the selected foreign Metros and Delhi/Calcutta Metros.

Implementing a metro project in a congested metropolis is indeed a challenge. In sheer size, magnitude and technical complexity there are no parallels to metro projects. Further, these projects are to be carried out in difficult urban environment without dislocating city life, while at the same time preserving the environment. The project involves integration of a number of complex technical systems – some of these technologies used in these systems are totally new to the country – each one of which is a major project by itself. Interfacing various system contracts is a difficult and highly skilled exercise. Side by side, timely and adequate funds have to be assured for implementation and lands, without encumbrances, have to be taken possession of in time. Clearances from the local authorities have to be taken permission to cut trees, diversion of utilities, management of road traffic, etc., all of which will call for an efficient and competent project implementing agency.

Metro projects cannot be executed the way Government agencies execute projects in this country. Timely completion is very important to safeguard the financial viability. Competent and skilled technical personal to man such an organisation are difficult to mobilize. In fact such experienced persons are not readily available in the country. Being a rail based project, for most of the systems such as rolling stock, signaling, telecommunication, traction power supply, etc., persons with railway background would be necessary.

Since PMMRC will not have the required expertise and experienced manpower to check and monitor the General Consultants it may be necessary to engage Prime Consultants from the very start of GC's assignment who will do this job on behalf of PMMRC. Delhi Metro Rail Corporation can be considered for being appointed as Prime Consultant to PMMRC.

14.4.1 High Power Committee

During the implementation of the project several problems with regard to acquisition of land, diversion of utilities, shifting of structures falling on the project alignment, rehabilitation of project affected persons, etc. are likely to arise. For expeditious resolution of these problems, an institutional mechanism needs to be set up at the State Government level. Towards this end, it is recommended that a High Power Committee under the chairmanship of Chief Secretary, Maharashtra should be set up. Other members of this Committee should be Secretaries of the concerned Departments of the State Government and Heads of civic bodies who will be connected in one way or the other with the implementation of the project. Commissioners of PMC and PCMC should also be the member of this committee. This Committee should meet once a month and sort out all problems brought before it by PMC and PCMC. For Delhi Metro also such a High Power Committee was set up and it proved very useful in smooth implementation of the Delhi Metro rail project.

14.4.2 Empowered Committee

At the Central Government level an Empowered Committee, under the chairmanship of Cabinet Secretary, is presently functioning for Delhi Metro project. Other members of this Committee are Secretaries of Planning Commission, Ministry of Home Affairs, Ministry of Urban Development, Ministry of Surface Transport, Ministry of Environment and Forests, Department of Expenditure, Chief Secretary of Delhi Government and a representative from the PMO. The Empowered Committee meets regularly and takes decisions on matters connected with inter-departmental coordination and overall planning, financing and implementation of the Delhi Metro project. It is suggested that the role of this Empowered Committee should be enlarged to include Mumbai Metro project also and the Chief Secretary, Maharashtra should be inducted as a member of this Committee.

14.4.3 Approval of GOI

Project may be got sanctioned by Government of India (GOI) after requisite clearances by the PRE PIB and PIB.

14.5 Legal Cover For Pune Metro

Government of India has passed Legislation as “The Metro Railways (Amendment) Act 2009” for implementation of metro rail in any metropolitan area and NCR. Copy of the Act is attached as Annexure. The implementation of metro in Pune may be taken up under the cover of above Act

14.6 CONCESSIONS FROM GOVERNMENT

Metro rail projects need very heavy investment. Loans have invariably to be taken to fund a part of the capital cost of the projects. These projects yield low financial internal rate of return. With reasonable fare level, servicing of these loans often pose problems. To make the project financially viable, therefore, the fares need to be substantially increased to socially un-acceptable levels. This results in the ridership coming down significantly, as it is sensitive to increases in the fare level. Thus the very objective of constructing the metro rail system to provide an affordable mode of mass travel for public is defeated. It, therefore, becomes necessary to keep the initial capital cost of a metro project as low as possible so that the fare level of the metro system can be kept at reasonable level.

As in the case of Delhi Metro, the State Government should exempt/reimburse the Maharashtra Value Added Tax (VAT) to Pune Metro. It should also exempt the following: -

- Tax on electricity required for operation and maintenance of the metro system.
- Municipal Taxes.

As per the present policy 80% of the Central Taxes will be paid by GOI as subordinate Debt and balance 20% will be paid by the concerned State Government. Maharashtra State Government may pursue the Central government to extend the same benefit to Pune Metro.

14.7 POSTING OF OSD

Since sanction of Pune Metro may take some time, It is recommended that Maharashtra State Government should urgently post an Officer on Special Duty (OSD) with adequate powers to process and persue sanction for this project and to take preliminary steps required for its implementation.

14.8 NEED FOR DEDICATED FUND FOR METRO PROJECTS

We also strongly recommend that the State Government start building up funds for the project through dedicated levies as has been done by other State Governments notably Karnataka.

To enable the State Governments to provide their share of equity in the Special Purpose Vehicles set up for such projects, it would be necessary to constitute a Special Metro Fund at the State Government level. The State Governments should resort to imposition of dedicated levies for raising resources for these Funds. Areas where such dedicated levies are possible is given below:

- A 50% cess on the tax levies for registration of road vehicles.
- A Surcharge on fuel (petrol, diesel).

The above two levies would also assist to discourage the use of personalized vehicles and encourage the use of public transport, which would not only reduce the pollution level in the city but also reduce traffic congestion on the road.


- Metro Tax @ 2% on pay rolls of all establishments having more than 100 employees. Such cess is in existence in a number of Western countries for raising resources for metro rail. The employer's benefit a good deal by good Metro System.
- Surcharge @ 10% on luxury tax on the earning of all Star Hotels. At present level, the luxury tax is 10%. The surcharge will raise the level to only 11%. Chinese cities have adopted this scheme.

Annexure - Metro Rail (Amendment Act) 2009

78

रजिस्ट्री सं. डी. एल.-33004/99

REGD. NO. D. L.-33004/99


सत्यमेव जयते

भारत का राजपत्र The Gazette of India

असाधारण
EXTRAORDINARY

भाग II—खण्ड 3—उप-खण्ड (ii)
PART II—Section 3—Sub-section (ii)

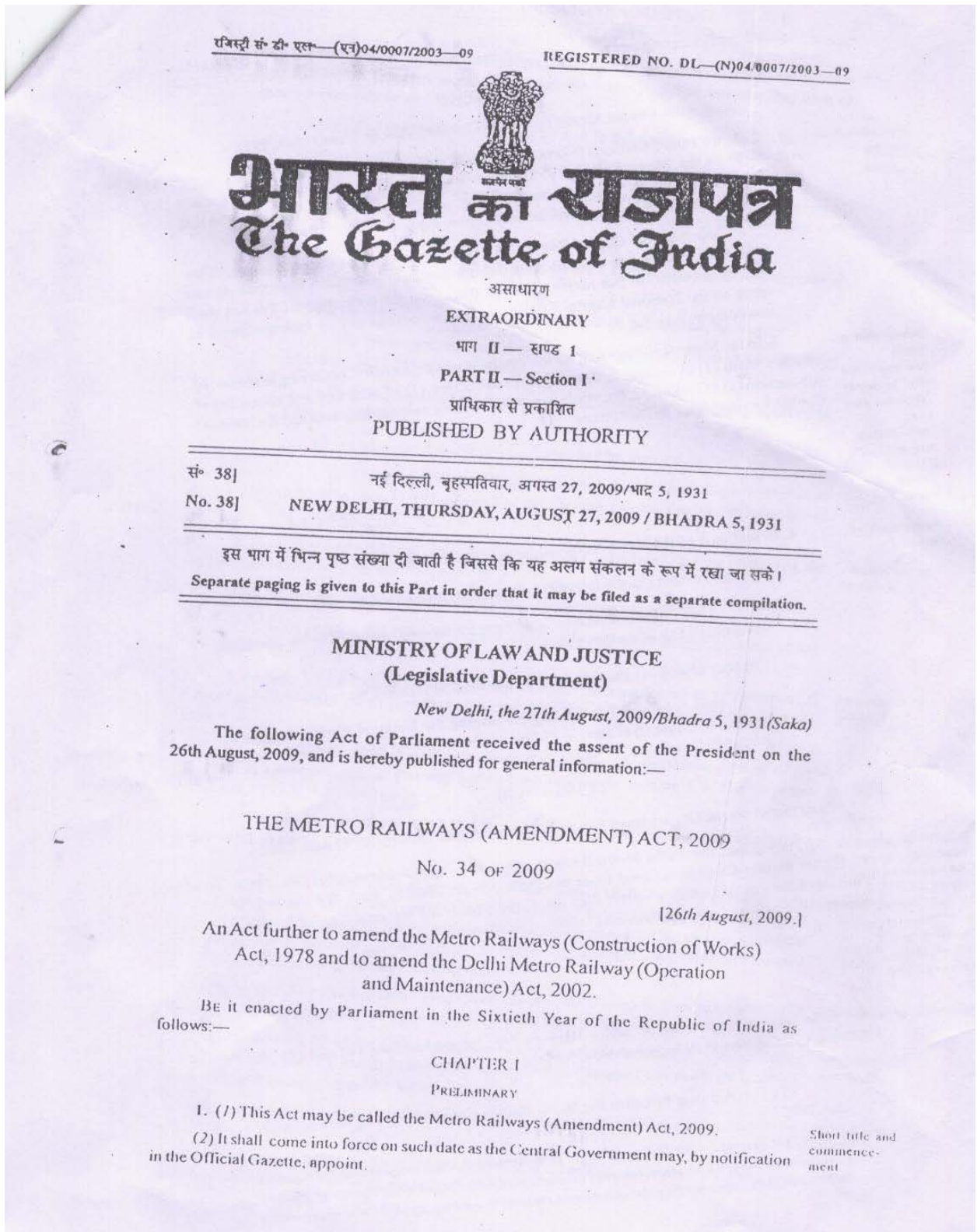
प्राधिकार से प्रकाशित
PUBLISHED BY AUTHORITY

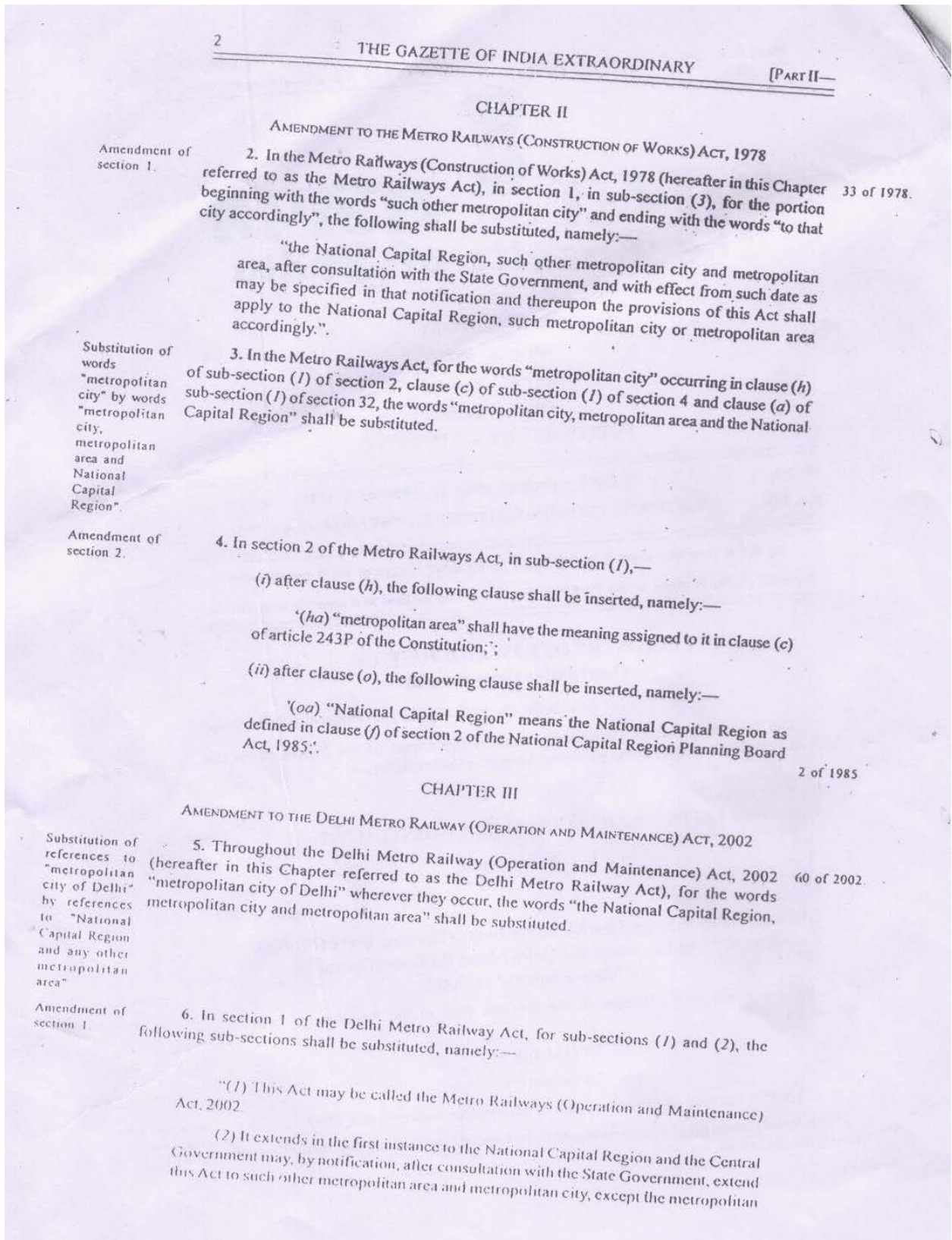
नई दिल्ली, सोमवार, सितम्बर 7, 2009/भाद 16, 1931
NEW DELHI, MONDAY, SEPTEMBER 7, 2009/BHADRA 16, 1931

<p>शहरी विकास मंत्रालय (मैट्रो रेल प्रकोष्ठ) अधिसूचना नई दिल्ली, 7 सितम्बर, 2009</p> <p>का.आ. 2279(अ).—केन्द्रीय सरकार, मैट्रो रेल (संशोधन) अधिनियम, 2009 (2009 का 34) की धारा 1 की उप-धारा (2) द्वारा प्रदत्त शक्तियों का प्रयोग करते हुए, 7 सितम्बर, 2009 को उस तारीख के रूप में नियत करती है, जिसको उक्त अधिनियम के उपबंध प्रवृत्त होंगे।</p> <p>[फा.सं. कं-14011/40/2003-एमआरटीएस/मैट्रो] बिमल कुजूर, अवर सचिव</p>	<p>MINISTRY OF URBAN DEVELOPMENT (Metro Rail Cell) NOTIFICATION New Delhi, the 7th September, 2009</p> <p>S.O. 2279(E).—In exercise of the powers conferred by sub-section (2) of Section 1 of the Metro Railways (Amendment) Act, 2009 (34 of 2009) the Central Government hereby appoints the Seventh September, 2009 as the date on which the provisions of the said Act. shall come into force.</p> <p>[F. No K-14011/40/2003-MRTS/Metro] BIMAL KUJUR, Under Secy.</p>
--	--

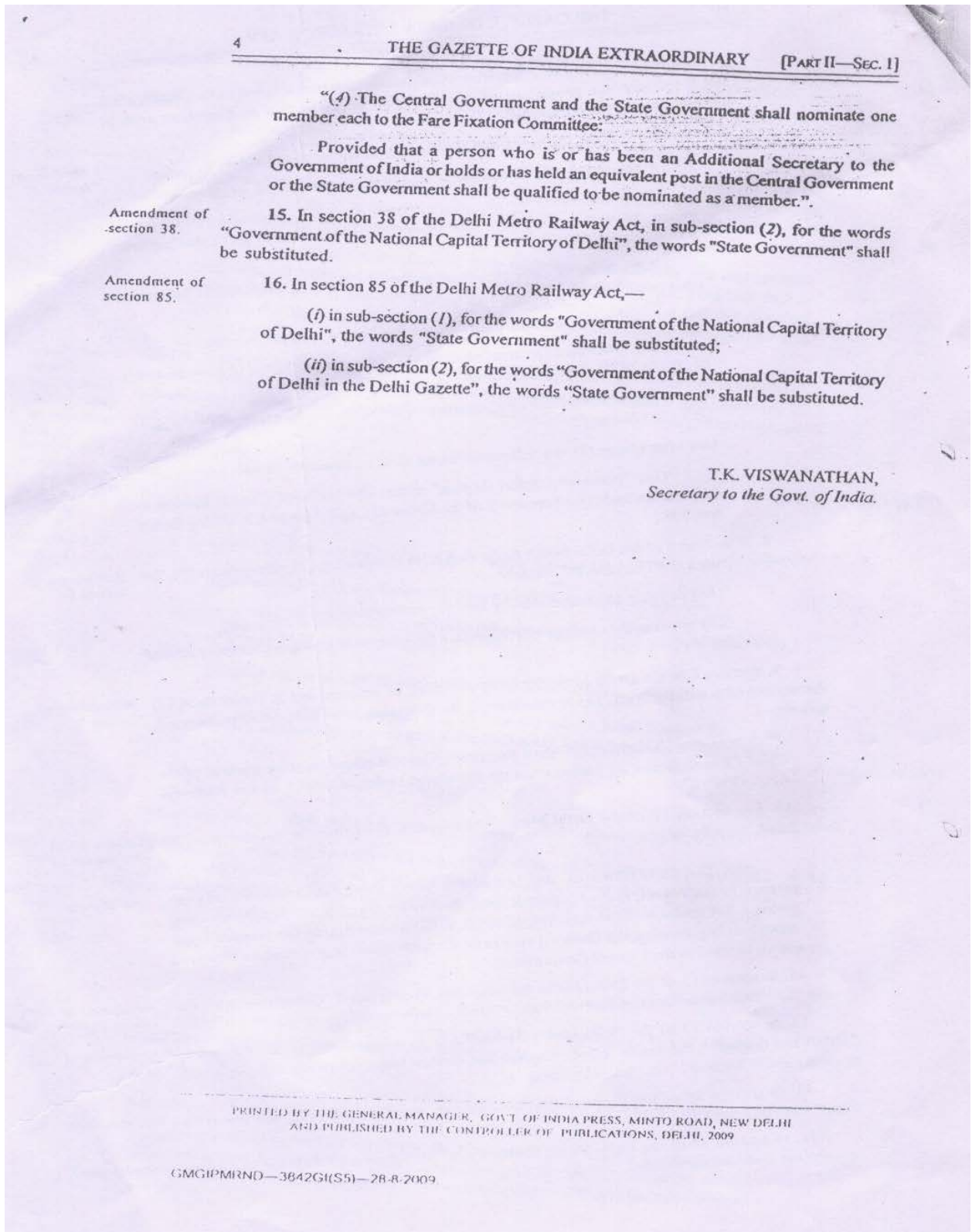
3262 GI 2009

Printed by the Manager, Govt. of India Press, Ring Road, Mayapuri, New Delhi-110064
and Published by the Controller of Publications, Delhi-110054





SEC. 1]	THE GAZETTE OF INDIA EXTRAORDINARY	3
	city of Calcutta, and with effect from such date as may be specified in that notification, and thereupon the provisions of this Act shall apply to that metropolitan area or metropolitan city accordingly.”	
	7. In section 2 of the Delhi Metro Railway Act, in sub-section (1),—	Amendment of section 2.
	(i) for clause (a), the following clauses shall be substituted, namely:—	
	‘(a) “Central Government”, in relation to technical planning and safety of metro railways, means the Ministry of the Government of India dealing with Railways;	
	(aa) “Claims Commissioner” means a Claims Commissioner appointed under section 48;”;	
	(ii) for clause (h), the following clauses shall be substituted, namely:—	
	‘(h) “metropolitan area” shall have the meaning assigned to it in clause (c) of article 243P of the Constitution;	
	(ha) “metropolitan city” means the metropolitan city of Bombay, Calcutta, Delhi or Madras;”;	
	(iii) after clause (k), the following clause shall be inserted, namely:—	
	‘(ka) “National Capital Region” means the National Capital Region as defined in clause (f) of section 2 of the National Capital Region Planning Board Act, 1985;”.	
2 of 1985.	8. In section 6 of the Delhi Metro Railway Act, in sub-section (2), after clause (b), the following clauses shall be inserted, namely:—	Amendment of section 6.
	“(ba) develop any metro railway land for commercial use;	
	(bb) provide for carriage of passengers by integrated transport services or any other mode of transport;”.	
	9. Section 7 of the Delhi Metro Railway Act shall be renumbered as sub-section (1) thereof and after sub-section (1) as so renumbered, the following sub-section shall be inserted, namely:—	Amendment of section 7.
	“(2) The Commissioner shall function under the administrative control of the Chief Commissioner of Railway Safety appointed under section 5 of the Railways Act, 1989.”.	
24 of 1989.	10. For section 12 of the Delhi Metro Railway Act, the following section shall be substituted, namely:—	Substitution of new section for section 12.
	“12. The Chief Commissioner of Railway Safety shall, for each financial year, prepare in such form, and within such time, as may be prescribed, an annual report giving a full account of the activities of the Commissioners during the financial year immediately preceding the financial year in which such report is prepared and forward copies thereof to the Central Government.”.	Annual report.
	11. In section 13 of the Delhi Metro Railway Act, for the word “Commissioner”, the words “Chief Commissioner of Railway Safety” shall be substituted.	Amendment of section 13.
	12. In section 23 of the Delhi Metro Railway Act, in sub-section (1), for the words “Hindi and English”, the words “Hindi, English and official language of the State in which such station is located” shall be substituted.	Amendment of section 23.
	13. In section 26 of the Delhi Metro Railway Act, in sub-section (1), the words “a small” shall be omitted.	Amendment of section 26.
	14. In section 34 of the Delhi Metro Railway Act, for sub-section (4), the following sub-section shall be substituted, namely:—	Amendment of section 34.



Chapter - 15

DISASTER MANAGEMENT MEASURES



- 15.1 Introduction
- 15.2 Need For Disaster Management Measures
- 15.3 Objectives:
- 15.4 List Of Serious Incidents Requiring Use Of Provisions Of The Disaster Management Measures
- 15.5 Provisions Under Disaster Management Act, 2005
- 15.6 Provisions At Metro Stations/Other Installations
- 15.7 Preparedness For Disaster Management



DISASTER MANAGEMENT MEASURES

15.1 INTRODUCTION

“Disaster is a crisis that results in massive damage to life and property, uproots the physical and psychological fabric of the affected communities and outstrips the capacity of the local community to cope with the situation.” Disasters are those situations which cause acute distress to passengers, employees and outsiders and may even be caused by external factors. As per the disaster management act, 2005 *“disaster” means a catastrophe, mishap, calamity or grave occurrence in any area, arising from natural or manmade causes, or by accident or negligence which results in substantial loss of life or human suffering or damage to, and destruction of, property, or damage to, or degradation of, environment, and is of such a nature or magnitude as to be beyond the coping capacity of the community of the affected area*”. As per world health organisation (who):

“Any occurrence that causes damage, economic disruption, loss of human life and deterioration of health and services on a scale sufficient to warrant an extra ordinary response from outside the affected community or area.”

A disaster is a tragic event, be it natural or manmade, which brings sudden and immense agony to humanity and disrupts normal life. It causes large scale human suffering due to loss of life, loss of livelihood, damages to property and persons and also brings untold hardships. It may also cause destruction to infrastructure, buildings, communication channels essential services, etc.

15.2 NEED FOR DISASTER MANAGEMENT MEASURES

The effect of any disaster spread over in operational area of Pune Metro is likely to be substantial as Pune Metro will deal with thousands of passengers daily in underground tunnels, viaducts and stations. Disaster brings about sudden and immense misery to humanity and disrupts normal human life in its established social and economic patterns. It has the potential to cause large scale human suffering due to loss of life, loss of livelihood, damage to property, injury and hardship. It may also cause destruction or damage to infrastructure, buildings and communication channels of Metro. Therefore there is an urgent need to provide for an efficient disaster management plan.

15.3 OBJECTIVES:

The main objectives of this Disaster Management Measures are as follows:

- Save life and alleviate suffering.
- Provide help to stranded passengers and arrange their prompt evacuation.
- Instill a sense of security amongst all concerned by providing accurate information.
- Protect Metro Rail property.
- Expedite restoration of train operation.
- Lay down the actions required to be taken by staff in the event of a disaster in Pune w Metro in order to ensure handling of crisis situation in coordinated manner.
- To ensure that all officials who are responsible to deal with the situation are thoroughly conversant with their duties and responsibilities in advance. It is important that these officials and workers are adequately trained in anticipation to avoid any kind of confusion and chaos at the time of the actual situation and to enable them to discharge their responsibilities with alertness and promptness.

15.4 LIST OF SERIOUS INCIDENTS REQUIRING USE OF PROVISIONS OF THE DISASTER MANAGEMENT MEASURES

Metro specific disasters can be classified into two broad categories e.g.: Man-made and Natural.

a. Man Made Disaster

1. Terrorist attack
2. Bomb threat/ Bomb blast
3. Hostage
4. Release of Chemical or biological gas in trains, stations or tunnels
5. Fire in metro buildings, underground/ elevated infrastructures, power stations, train depots etc.
6. Train accident and train collision/derailment of a passenger carrying train
7. Sabotage
8. Stampede

b. Natural Disaster

1. Earthquakes
2. Floods

15.5 PROVISIONS UNDER DISASTER MANAGEMENT ACT, 2005**A. The National Disaster Management Authority (NDMA)**

Establishment of National Disaster Management Authority:-

- (1) With effect from such date as the Central Government may, by notification in the Official Gazette appoint in this behalf, there shall be established for the purposes of this Act (*The Disaster Management Act, 2005*), an authority to be known as the National Disaster Management Authority.
- (2) The National Authority shall consist of the Chairperson and such number of other members, not exceeding nine, as may be prescribed by the Central Government and, unless the rules otherwise provide, the National Authority shall consist of the following:-
 - (a) The Prime Minister of India, who shall be the Chairperson of the National Authority, ex officio;
 - (b) Other members, not exceeding nine, to be nominated by the Chairperson of the National Authority.
- (3) The Chairperson of the National Authority may designate one of the members nominated under clause (b) of sub-section (2) to be the Vice- Chairperson of the National Authority.
- (4) The term of office and conditions of service of members of the National Authority shall be such as may be prescribed.

B. State Disaster Management Authority:

Establishment of State Disaster Management Authority:-

- (1) Every State Government shall, as soon as may be after the issue of the notification under sub-section (1) of section 3, by notification in the Official Gazette, establish a State Disaster Management Authority for the State with such name as may be specified in the notification of the State Government.
- (2) A State Authority shall consist of the Chairperson and such number of other members, not exceeding nine, as may be prescribed by the State Government and,

unless the rules otherwise provide, the State Authority shall consist of the following members, namely:-

- (a) The Chief Minister of the State, who shall be Chairperson, ex officio;
 - (b) Other members, not exceeding eight, to be nominated by the Chairperson of the State Authority;
 - (c) The Chairperson of the State Executive Committee, ex officio.
- (3) The Chairperson of the State Authority may designate one of the members nominated under clause (b) of sub-section (2) to be the Vice- Chairperson of the State Authority.
- (4) The Chairperson of the State Executive Committee shall be the Chief Executive Officer of the State Authority, the Chief Minister shall be the Chairperson of the Authority established under this section.
- (5) The term of office and conditions of service of members of the State Authority shall be such as may be prescribed.

C. Command & Control at the National, State & District Level

The mechanism to deal with natural as well as manmade crisis already exists and that it has a four tier structure as stated below:-

- (1) National Crisis Management Committee (NCMC) under the chairmanship of Cabinet Secretary
- (2) Crisis Management Group (CMG) under the chairmanship of Union Home Secretary.
- (3) State Level Committee under the chairmanship of Chief Secretary.
- (4) District Level Committee under the Chairmanship of District Magistrate.

All agencies of the Government at the National, State and district levels will function in accordance with the guidelines and directions given by these committees.

D. Plans by Different Authorities at District Level and their Implementation

Every office of the Government of India and of the State Government at the district level and the local authorities shall, subject to the supervision of the District Authority:-

- (a) Prepare a disaster management plan setting out the following, namely:-

- (i) Provisions for prevention and mitigation measures as provided for in the District Plan and as is assigned to the department or agency concerned;
 - (ii) Provisions for taking measures relating to capacity-building and preparedness as laid down in the District Plan;
 - (iii) The response plans and procedures, in the event of, any threatening disaster situation or disaster;
- (b) Coordinate the preparation and the implementation of its plan with those of the other organizations at the district level including local authority, communities and other stakeholders;
- (c) Regularly review and update the plan; and
- (d) Submit a copy of its disaster management plan, and of any amendment thereto, to the District Authority.

15.6 PROVISIONS AT METRO STATIONS/OTHER INSTALLATIONS

To prevent emergency situations and to handle effectively in case 'one arises' there needs to be following provisions for an effective system which can timely detect the threats and help suppress the same.

- i) Fire detection and suppression system
- ii) Smoke management
- iii) Environmental control system (ECS)
- iv) Tunnel ventilation system
- v) Track-way exhaust system (TES)
- vi) Station power supply system
- vii) DG sets & UPS
- viii) Lighting system
- ix) Station area lights
- x) Tunnel lighting
- xi) Tunnel lighting control
- xii) Seepage system
- xiii) Water supply and drainage system
- xiv) Sewage system
- xv) Any other system deemed necessary

The above list is suggestive not exhaustive actual provisioning has to be done based on site conditions and other external and internal factors.

15.7 PREPAREDNESS FOR DISASTER MANAGEMENT

Being a technological complex system worked by new set of staff, with a learning curve to improve and stabilize with time, intensive mock drills for the staff concerned is very essential to train them to become fully conversant with the action required to be taken while handling emergencies.

They also need to be trained in appropriate communication skills while addressing passengers during incident management to assure them about their well being seeking their cooperation.

Since learning can only be perfected by 'doing' the following Mock Drills are considered essential:

- a. Fire Drill
- b. Rescue of a disabled train
- c. Detrainment of passengers between stations
- d. Passenger evacuation from station
- e. Drill for use of rescue & relief train.
- f. Hot line telephone communication with state disaster management

Chapter - 16

DISABLED FRIENDLY FEATURES



- 16.1 Introduction
- 16.2 Content
- 16.3 Rail Transport
- 16.4 Information Signs And Announcements
- 16.5 Metro Railway Stations
- 16.6 Information Systems
- 16.7 General And Accessible Toilets
- 16.8 Drawing Water Events
- 16.9 Visual Contrasts
- 16.10 Emergency Egrees/Evacuation
- 16.11 Alerting Systems
- 16.12 Written Evacuation Procedure
- 16.13 Emergency Evacuation Route
- 16.14 Way Guidance System
- 16.15 Fire Resistant Doors
- 16.16 Street Design
- 16.17 Traffic Signals
- 16.18 Subway And Foot Over Bridge
- 16.19 Alighting And Boarding Areas
- 16.20 Approach
- 16.21 Car Park



Chapter – 16

DISABLED FRIENDLY FEATURES

16.1 INTRODUCTION

The objective of making this chapter is to create a user-friendly mass transport system in India which can ensure accessibility to persons with disabilities, people travelling with small children or are carrying luggage, as well as people with temporary mobility problems (e.g. a leg in plaster) and the elderly persons.

The design standards for universal access to Public Transport Infrastructure including related facilities and services, information, etc. would benefit people using public transport.

The access standards given here are extracted from Indian Roads Congress Code, IRC 103: 2012, Guidelines for Pedestrian Facilities; Model Building Bye-Laws, 2011 and National Building Code, 2005. Central Public Works Department's (CPWD) "Space Standards for Barrier Free Built Environment for Disabled and Elderly Persons", 1998 and 2013 edition (under revision by MoUD), and international best practices / standards. Further, it has also been attempted to provide guidelines/ standards for alighting and boarding area, approach to station, car parking area, drop-off and pick-up areas, taxi/auto rickshaw stand, bus stand/stop, footpath (sidewalk), kerb ramp, road intersection, median/pedestrian refuge, traffic signals, subway and foot over bridge etc. to achieve a seamless development around metro stations.

16.2 CONTENT

1. Rail Transport

2. Metro Rail Station

- Way finding
- Signage
- Automated Kiosks
- Public Dealing Counters
- Audio-visual Displays
- Public Telephones
- Rest Areas/Seating

- Tactile Paving - Guiding & Warning
- Doors
- Steps & Stairs
- Handrails
- Ramps
- Lifts/Elevators
- Platform/Stair Lift
- General and Accessible toilets
- Drinking Water Units
- Visual Contrasts
- Emergency Egress/Evacuation

3. Street Design

- Footpath (Sidewalk)
- Kerb Ramp
- Road Intersection
- Median/Pedestrian Refuge
- Traffic Signals
- Subway and Foot Over Bridge

4. Alighting and Boarding Area

- Approach
- Car Park
- Drop-off and Pick-up Areas
- Taxi/Auto Rickshaw Stand
- Bus Stand/Stop

16.3 RAIL TRANSPORT

1. General

- ▶ Whether over-ground or underground, rail travels is a highly effective mode of transport.
- ▶ Every train should contain fully accessible carriages.
- ▶ Staff should be trained in methods of assistance and be at hand on request.
- ▶ Stations for all rail travel should be fully accessible with extra wide turnstiles where possible alongside wheelchair accessible doorways

- ▶ Staff should be on hand to assist persons with disabilities and elderly to enter or exit through convenient gates.
- ▶ All new railway stations should be designed to be fully accessible.
- ▶ For persons with hearing impairments, an electronic sign board (digital display) should be displayed on each platform at conspicuous location for all announcements made by the railways.
- ▶ For persons with visual impairments audio system announcing the station names and door location should be available.

2. Accessible Railway Cars

The railway cars should have the following features:

- ▶ Railway car doors should be at least 900 mm wide;
- ▶ The gap between the car doors and the platform should preferably be less than 12 mm;
- ▶ Identification signage should be provided on the doors of wheelchair accessible coach
- ▶ If the car floor at its door and the platform cannot be at the same level, then at least one car doors should have apparatus such as a hydraulic lift or pull-out ramp installed in the doorway for wheelchair users.

3. Wheel Chair Space

- ▶ Space for a wheel chair should be available at the side of the door:-
- ▶ The space should be indicated inside and outside the car by using the international symbol of access; and
- ▶ Wheel stoppers and ring-strap or other appropriate safety grip should be provided for wheelchair users.

4. Seats

- ▶ An appropriate number of designated seats for passengers with disabilities and elderly people should be provided near the doors.

5. Aisles

- ▶ Aisles should be at least 900 mm wide.

16.4 INFORMATION SIGNS AND ANNOUNCEMENTS

A map of train routes should be installed at a conspicuous place at the station preferably near the ticketing window. A map in Braille/raised numbers shall be maintained at the enquiry/ticketing window. In each car, there should be an announcement and provision of a visual display of the names of stations en route.

16.5 METRO RAILWAY STATIONS

1. LEVEL APPROACH

- Approach route should not have level differences. If the station is not on the same level as the walkway or pathway, it should have a ramp.
- Walkway surfaces should be non-slip.
- Approach walkway should have tactile pavements for persons with visual impairments.

2. STATION ENTRANCES AND EXITS

- These should have a minimum width of 1800mm and is level or ramped.

3. RESERVATION AND INFORMATION COUNTERS

- Should have clear floor space of at least 900 mm x 1200 mm in front of the counters;
- There should be at least one low counter at a height of 750 mm to 800 mm from the floor with clear knee space of 750 mm high by 900 mm wide by 480 mm deep.
- At least one of the counters should have an induction loop unit to aid people with hearing impairments; and
- The counters should have pictographic maps indicating all the services offered at the counter and preferably one of the counter staff should be sign language literate.

4. TOILET FACILITIES

- There should be at least one unisex accessible toilet
- Ticket Gates

At least one of the ticket gates should:

- Be minimum 900 mm wide to allow a wheelchair user through; and
- Have a continuous line of guiding paver for people with visual impairments.

5. PLATFORMS

The Platforms should:

- Have a row of warning paver installed 600mm before the track edge (photo 6);
- Have non-slip and level flooring;
- Have seating areas for people with ambulatory disabilities;
- Be well illuminated lux level 35 to 40;
- There should preferably be no difference in level between the train entry door and the platform and the gap between car floor at entry door and platform edge shall preferably be not more than 12 mm.
- All platforms should inter-connect by means of an accessible routes or lifts; and provide accessible level entrance to the train coach.

6. WAY FINDING

- Way finding references should be available at decision points.
- Colour can be used to identify routes and provide assistance in locating doors, walls and hazards. Proper colour contrast between different elements greatly improves visibility for all users and is critical for persons with low vision. For example, colour contrasting of door frames can assist in locating doors, and likewise floors should be contrasted with walls. In addition, furniture should contrast with walls and floors so as not to create an obstacle.
- Structural elements such as columns should be colour contrasted or brightly marked so as to be visible to those who may have a visual disability.
- Generally, patterns on flooring should be avoided or else should be minimal and small to avoid visual confusion.
- In addition to identifying hazards or warnings, tactile floor surfaces can also be used to inform that there is a change in area (e.g. leaving a corridor and entering a boarding area).
- Tactile systems should be consistent throughout the building. For example, terminals should not have carpeting in some boarding areas and tile in others as this may create confusion for those who rely on tactile surfaces to guide them to their destination.
- Good lighting assists those with a visual disability to see better and allows people who have a hearing impairment to lip read easier. However, care should be taken to properly direct lighting and to use matte finishes on floors, walls and signage, so as not to create glare which may create difficulties for all travelers.
- Blinds can be used to adjust lighting levels in areas where the natural lighting changes significantly throughout the day.

7. SIGNAGE

Signs must be clear, concise, and consistent. All travelers need clear information about the purpose and layout of terminals to maintain a sense of direction and independent use of all facilities. Using internationally and nationally established symbols and pictograms with clear lettering and Braille ensures universal accessibility cutting across regional/cultural and language barriers. A cohesive information and signage system can provide visual (e.g. signs, notice boards), audible (e.g. public address and security systems, induction loops, telephones, and infrared devices), and/ or tactile information (e.g. signs with embossed lettering or Braille).

8. SIGN DESIGN SPECIFICATIONS

- The sign should be in a prominent position.
- The face of the sign should be well-illuminated by natural or artificial light.
- Letters should be simple such as Arial, Helvetica medium, and san serif or similar and numbers should be Arabic.

- The colour of the text should be in a colour that contrasts with the sign board.
- The sign board should also contrast with the wall on which it is mounted.
- The surface of the sign should not be reflective.
- Some signs such as those adjacent to or on a toilet door may be embossed so that they can be read by touch.
- Illuminated signs should not use red text on a dark background.
- Signs should be supplemented by Braille where possible.



F

fig. 19.1 - Way finding signage



Fig. 19.2 - International Symbol of Accessibility

9. AUTOMATED KIOSKS

- Automated kiosks should be accessible for wheelchair users.
- Should be clearly marked with international symbol of accessibility.
- Should have Braille buttons and audio announcement system for persons with vision impairments.
- Operations should be easy to understand and operate for persons with learning disabilities, intellectual disabilities, and elderly persons.

10. PUBLIC DEALING COUNTERS

-
- Ticketing, Information, Check-in, Help desk, Restaurants, Shops, etc. should have public dealing counters.
- Information or help desks should be close to the terminal entrance, and highly visible upon entering the terminal. In addition, they should be clearly identified and accessible to both those who use wheelchairs and those who stand.
- It should provide information in accessible formats, viz. Braille leaflets for persons with vision impairments.

- Ideally, these desks should have a map of the facility that desk attendants can view with passengers, when providing directions.
- Staff manning the counters should know sign language wherever possible.
- Information desk acoustics should be carefully planned and controlled as a high level of background noise is confusing and disorienting to persons with hearing impairment.
- Lighting should be positioned to illuminate the receptionist/person manning the counter and the desk top without creating glare.
- Lighting should not create shadows over the receptionist staff, obscuring facial detail and making lip reading difficult.
- There should be a hearing enhancement system such as a loop induction unit, the availability of which is clearly indicated with a symbol.
- One of the counters should not be more than 800mm from the floor, with a minimum clear knee space of 650mm high and 280mm- 300mm deep .

11. AUDIO-VISUAL DISPLAYS

- Terminal maps should be placed so that they are readily visible to persons who are standing and persons who use wheelchairs. They should also be accessible to persons with a visual disability (i.e. tactile maps). Other alternatives include electronic navigation systems or audio maps.
- Enable captioning at all times on all televisions and other audiovisual displays that are capable of displaying captions and that are located in any portion of the terminal.
- The captioning must be in high contrast for all information concerning travel safety, ticketing, check-in, delays or cancellations, schedule changes, boarding information, connections, checking baggage, individuals being paged by bus railway or airlines, vehicle changes that affect the travel of persons with disabilities, and emergencies (e.g., fire, bomb threat).

12. REST AREAS/SEATING

- Seating area / benches should be provided along the circulation path at regular intervals so that passengers do not need to walk more than 50 to 60 metres before being able to sit and rest.
- Where seating is provided, designated seating for passengers with disabilities is to be provided at boarding gates and departure areas within viewing distance of communication boards and/or personnel and identified by the symbol of access.
- Public transit operators should provide seating in passenger service areas where there may be long waiting lines or times, including at ticket sales counters, check-in counters, secured screening and during inter-country travel in customs areas and baggage retrieval areas.
- Designated seating should be provided for at boarding gates and departure areas within viewing distance of communication boards, and within hearing range of audio

announcements as well. Such seating areas should be identified by the symbol of accessibility and shelter should be provided where this seating is outdoors.

- In outdoor settings, seating should be provided along with the planned hawker spaces.
- At waiting lounges for persons with disabilities chairs should have armrests and backrest.

13. TACTILE PAVING- GUIDING & WARNING¹

(a) Tactile Guiding Paver (Line-Type)

It is recommended to install a row of tactile guidance paver along the entire length of the proposed accessible route for visual impaired persons. Care must be taken to ensure that there are no obstacles, such as wall, pillar, uneven surfaces, Soffit (underside /open area under the stairs, along the route traversed by the guidance paver. Also, there should be clear headroom of at least 2.1 meters height above the tactile guidance paver, free of protruding objects such as overhanging advertisement panel and signage, along the entire length of the walk.

(b) Tactile Warning Paver (Dot-Type)

Indicate an approaching potential hazard or a change in direction of the walkway, and serve as a warning of the approaching danger to persons with visual impairments, preparing them to tread cautiously and expect obstacles along the travel path, traffic intersections, doorways, stairs, etc. They are used to screen off obstacles, drop-offs or other hazards, to discourage movement in an incorrect direction, and to warn of a corner or junction. Two rows of tactile warning paver should be installed across the entire width of the designated accessible passenger pathway at appropriate places such as before intersections, terminal entrances, obstacles such as signage, and each time the walkway changes direction.

14. PLACES TO INSTALL WARNING PAVER

- In front of an area where traffic is present.
- In front of an entrance/exit to and from a staircase or multi-level crossing facility.
- Entrances/exits at public transport terminals or boarding areas.

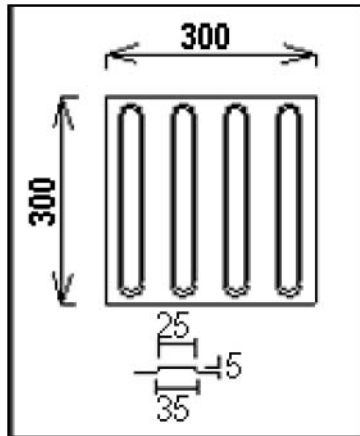


Fig. 19.3 - Guiding paver

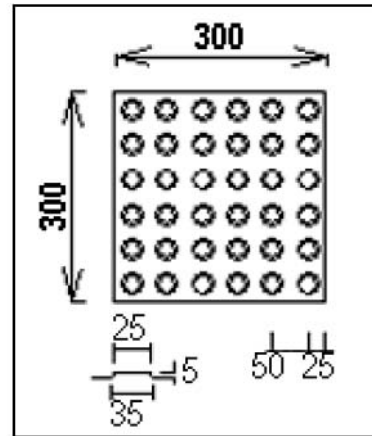


Fig. 19.4 - Warning paver



15. DOORS

Whatever the type of entrance door, it must be wide enough to accommodate passenger traffic comfortably.

- The recommended minimum clear opening width of an internal door is 900mm minimum.
- Where doors comprise two leaves (i.e. double doors), each leaf should be 900mm min. wide, so that persons carrying large items and people using wheelchairs do not have to open both leaves.
- Manual doors should incorporate kick plates 300-400mm high to withstand impact of wheelchair footrest (this is especially important where doors are glazed).
 - Also be fitted with vision panels at least between 900mm and 1500mm from floor level.
 - Be color contrasted with the surrounding wall and should not be heavier than 22N to open.
 - Lever handles and push type mechanisms are recommended . When a sliding door is fully open, handles should be usable from both sides.
- Where revolving doors or turnstiles are used, an alternative wheelchair-accessible entrance must also be provided.
- A distance of 400mm should be provided beyond the leading edge of door to enable a wheelchair user to maneuver and to reach the handle.
- To ensure maximum clarity for persons with visual impairments, the entrance should be easily distinguishable from its surroundings by the effective use of landscaping, signage, colour (preferably yellow/orange), tonal contrast and tactile surfacing.
- Door hardware should be positioned between 900-1000mm above floor.
- Operable devices such as handles, pulls, latches and locks should:
 - Be operable by one hand
 - Not require fine finger control, tight grasping, pinching or twisting to operate
- Glazed doors and fixed glazed areas should be made visible by use of a clear, colour and tone contrasted warning or decorative feature that is effective from both inside and outside and under any lighting conditions, e.g. a logo, of minimum dimensions 150mm by 150mm (though not necessarily square), set at eye level.

16. STEPS & STAIRS

- Steps should be uniform with the tread not less than 300mm and the risers 150mm.
- The risers should not be open.
- The steps should have an unobstructed width of 1200mm minimum.
- All steps should be fitted with a permanent colour and tone contrasting at the step edge, extending the full width of the step, reaching a minimum depth of 50mm on both tread

and riser.

- Have continuous handrails on both sides including the wall (if any) at two levels
- Warning paver to be placed 300mm at the beginning and at the end of all stairs.
- Nosing to be avoided.
- The staircase should be adequately and uniformly illuminated during day and night (when in use). The level of illumination should preferably fall between 100-150 lux.
- The rise of a flight between landings must be no more than 1200mm.
- There should be no more than 12 risers in one flight run.
- The stair covering and nosing should be slip-resistant, non-reflective, firmly-fixed and easy to maintain.
- Soffit (underside /open area under the stairs) of the stairs should be enclosed or protected.

17. HANDRAILS

- Handrails should be circular in section with a diameter of 38-45mm and formed from materials which provide good grip such as timber, nylon or powder coating, matt finish metal finishes.
- The handrail should contrast in colour (preferably yellow/orange) with surrounding surfaces.
- At least 50mm clear of the surface to which they are attached and should be supported on brackets which do not obstruct continuous hand contact with the handrail.
- The handrail should be positioned at two levels- 760mm and 900mm above the pitch-line of a flight of stairs.
- Handrail at foot of the flight of stairs should extend 300mm beyond the stairs in the line of travel and returning to the wall or floor or rounded off, with a positive end that does not project into the route of travel.

18. RAMPS

- Ramps gradient should ideally be 1 in 20 and no greater than 1 in 12.
- Width of the ramp should not be less than 1200mm and preferred width is 1800mm.
- The steeper the gradient, the shorter the length of ramp between landings.
- On long ramps, a horizontal resting space should be provided every 6 meters.
- Surface materials should be slip-resistant, non-reflective, firmly-fixed and easily maintained
- The edge of the ramp should have an edge protection with a minimum height of 100mm.
- Landings every 750mm of vertical rise.
- A tapping or lower rail should be positioned so that its bottom edge is no higher than 200mm above ground level.
- Handrails on the ramps should be on both sides at two levels: upper at 900mm and

lower at 760mm; both end to be rounded and grouted; extend 300 mm beyond top and bottom of ramp .

- A row of tactile warning paver should be placed 300mm beginning and end of each run.
- Landings should be provided at regular intervals as indicated in the table (Table 1).

Table 19.1 - Specifications for Ramps

Level difference	Minimum gradient of Ramp	Ramp Width	Handrail on both sides	Comments
≥ 150 mm ≤ 300 mm	1:12	1200 mm	√	
≥ 300 mm ≤ 750 mm	1:12	1500 mm	√	Landings every 5 meters of ramp run.
≥ 750 mm ≤ 3000mm	1:15	1800 mm	√	Landings every 9 meters of ramp run.
≥ 3000 mm	1:20	1800 mm	√	Landings every 9 meters of ramp run.

19. LIFTS/ELEVATORS

A carefully designed lift makes a huge contribution to the accessibility of a multi-storied terminal building for persons with disabilities.

- Lift locations should be clearly signposted from the main pedestrian route and recognizable through design and location.
- The colour and tone of the lift doors should contrast with the surrounding wall finish to assist in their location. Lift doors with metallic finishes such as steel grey and silver should be avoided as they are difficult to identify by persons with low vision.
- The lift lobby shall be of an inside measurement of 1800mm X 2000mm or more. A clear landing area in front of the lift doors of minimum dimensions 1500mm x 1500mm should be provided.
- By making the landing area distinguishable by floor surface and contrast, it will aid location and recognition of core areas. This could comprise a change in floor finish from thin carpet to vinyl/PVC, or cement/mosaic floor to carpet.
- Changes in floor finish must be flushed. There should be no level difference between lift door and the floor surface at each level; the gap if unavoidable should not be more than 12mm.
- The floor level/location should be indicated on the wall adjacent to or just above the call buttons, and opposite the lift doors where possible.

20. LIFT DIMENSIONS

- Provisions of at least one lift shall be made for people using wheelchairs with the following car dimensions:

- Clear internal depth -1500 mm minimum
- Clear internal width - 1500 mm minimum
- Entrance door width - 900 mm minimum

21. LIFT CONTROLS

- The lift call button should be wall-mounted adjacent to the lift and should contrast with wall finish, either by using a contrasting panel, or a contrasting border around the button panel.
- The call buttons should be located within the range 800-1000mm above floor finish.
- Buttons should not be touch sensitive, but should require a light positive pressure and should ideally be large enough to be operable by the palm of the hand if required.
- The control buttons inside the lift should be positioned on the side wall rather than front wall to allow access from the back and front of the lift car, by mobility aid users like wheelchair users.
- The control buttons should contrast with their surroundings and illuminate when pressed and should incorporate highly visible tactile embossed (NOT engraved) characters and in Braille.
- Time of closing of an automatic door should be more than 5 seconds and the closing speed should not exceed 25 meters per second. There should be a provision of censor enabled closing.
- In larger lifts, controls should be positioned on both side walls, at least 400mm from front wall and between 800-1000mm above floor level.

22. CAR DESIGN

- Internal walls should have a non-reflective, matt finish in a colour and tone contrasting with the floor, which should also have a matt, non-slip finish.
- Use of reflective materials such as metal (stainless steel for example) can be problematic in creating sufficient contrast with control buttons, emergency telephone cabinet, etc. for persons with low vision and the use of such materials should be avoided wherever possible.
- A mirror (750mm above floor level) on the rear wall can be useful to persons using wheelchairs and other mobility aids should they need to reverse safely out of the lift car or view the floor numbers.
- Internal lighting should provide a level of illumination of minimum 100 lux (approximately 50-75 lux at floor level), uniformly distributed, avoiding the use of spotlights or down lighters.
- A grab bar should be provided along both sides and the back wall, 900mm above floor level.
- Handrails should be of tubular or oval cross section, in order to be easily gripped and capable of providing support.
- Handrails should be positioned so that there is a clear space behind the handrail to allow it to be grasped i.e. knuckle space should be 50mm.

16.6 INFORMATION SYSTEMS

- Lifts should have both visual and audible floor level indicators
- Audible systems are also usually capable of incorporating additional messages, such as door closing, or, in the case of an emergency, reassurance (with manual over-ride allowing communication with lift occupants).
- Announcement system should be of 50 decibel.
- The display could be digital or segmented LED, or an appropriate alternative. A yellow or light green on black display is preferred to a red on black display as it is easier to read.

16.7 GENERAL AND ACCESSIBLE TOILETS

1. SIGNAGES

- All signage of general toilets should be in bold and contrasting colors.
- For persons with low vision and vision impairments: male pictogram in triangle and female pictogram in circle, marked on plates along with Braille & raised alphabets, to be mounted on wall next to door near the latch side, at a height between 1400mm-1600mm.
- Warning strip/ thin rubber door mat to be provided 300mm before and after the toilet entrance.
- Tactile paver to be provided for urinals, WC and washbasins for persons with vision impairments.

2. ACCESSIBLE TOILETS

- Should have the international symbol of accessibility displayed outside for wheelchair access.
- The toilet door should be an outward opening door or two way opening or a sliding type and should provide a clear opening width of at least 900mm.
- It should have a horizontal pull-bar, at least 600mm long, on the inside of the door, located so that it is 130mm from the hinged side of the door and at a height of 1000mm.

3. WC COMPARTMENT DIMENSIONS

- The dimensions of a unisex toilet are critical in ensuring access. The compartment should be at least 2200mm and 2000mm. This will allow use by both manual and motorized wheelchair users.
- Layout of the fixtures in the toilet should be such that a clearing maneuvering space of 1500mm x 1500mm in front of the WC and washbasin.

4. WATER CLOSET (WC) FITTINGS

- Top of the WC seat should be 450-480mm above finished floor level, preferably be of

wall hung or corbel type as it provides additional space at the toe level.

- An unobstructed space 900mm wide should be provided to one side of the WC for transfer, together with a clear space 1200mm deep in front of the WC.
- WC should be centred 500mm away from the side wall, with the front edge of the pan 750mm away from the back wall. Have a back support. The WC with a back support should not incorporate a lid, since this can hinder transfer.
- L-shape grab bar at the adjacent wall and on the transfer side (open side) swing up grab bar shall be provided.
- The cistern should have a lever flush mechanism, located on the transfer side and not on the wall side and not more than 1000mm from the floor.

5. GRAB BARS

- Grab bars should be manufactured from a material which contrasts with the wall finish (or use dark tiles behind light colored rails), be warm to touch and provide good grip.
- It is essential that all grab rails are adequately fixed, since considerable pressure will be placed on the rail during maneuvering. Grab bars should sustain weight of 200kgs minimum.
- A hinged type moveable grab bar should be installed adjacent to the WC on the transfer side. This rail can incorporate a toilet tissue holder. A distance of 320mm from the centre line of the WC between heights of 200-250mm from the top of the WC seat. It should extend 100-150mm beyond the front of the WC.
- A fixed wall-mounted L- shape grab bar (600mm long horizontal and 700mm long vertical) on the wall side should be provided. It should be placed at a height of 200-250mm above the WC seat level.

6. WASHBASINS

- Hand washbasins should be fitted on cantilevered brackets fixed to the wall.
- The basin should be fixed no higher than 750mm above the finished floor level.
- Be of dimensions 520mm and 410mm, mounted such that the top edge is between 800-900mm from the floor; have a knee space of at least 760mm wide by 200mm deep by 650-680mm high.
- The position of the basin should not restrict access to the WC i.e. it should be located 900mm away from the WC.
- A lever operated mixer tap fitted on the side of the basin closest to the WC is useful as it allows hot and cold water to be used from a seated position on the WC.
- The hand drying facilities should be located close to the hand washbasin between 1000-1200mm.
- Lever type handles for taps are recommended.
- Mirror's bottom edge to be 1000mm from the floor and may be inclined at an angle.

7. FIXTURES AND FITTINGS

- Contrast between fittings and fixtures and wall or floor finishes will assist in their location. For example, using contrasting fittings, or dark tiles behind white hand washbasins and urinals, contrasting soap dispensers and toilet roll holders. Contrast between critical surfaces, e.g. floors, walls and ceilings helps to define the dimensions of the room.
- Towel rails, rings and handrails should be securely fixed to the walls and positioned at 800-1000mm from the floor.
- The mirror should be tilted at an angle of 30° for better visibility by wheelchair users.
- It should have lower edge at 1000mm above floor finish and top edge around 1800mm above floor finish.
- Hooks should be available at both lower-1200mm and standard heights- 1400mm, projecting not more than 40mm from the wall.
- Where possible, be equipped with a shelf of dimensions 400mm x 200mm fixed at a height of between 900mm and 1000mm from the floor.
- Light fittings should illuminate the user's face without being visible in the mirror. For this reason, most units which have an integral light are unsatisfactory.
- Large, easy to operate switches are recommended, contrasting with background to assist location, at a maximum height of 1000mm above floor finish.
- All toilet facilities should incorporate visual fire alarms.
- Alarms must be located so that assistance can be summoned both when on the toilet pan i.e. at 900mm height and lying on the floor i.e. at 300mm, from floor surface. Alarms should be located close to the side wall nearest the toilet pan, 750mm away from rear wall and at 900mm and 200mm above floor finish

8. SIGNAGE OF ACCESSIBLE TOILETS

- All unisex accessible toilets to have access symbol in contrast colours. A distinct audio sound (beeper/clapper) may be installed above the entrance door for identification of the toilets.



Fig. 19.5 - Signage for accessible washroom

9. ACCESSIBLE URINAL

- At least one of the urinals should have grab bars to support ambulant persons with disabilities (for example, people using mobility aids like crutches).
- A stall-type urinal is recommended.
- Urinals shall be stall-type or wall-hung, with an elongated rim at a maximum of 430mm above the finish floor. This is usable by children, short stature persons and wheelchair users.
- Urinal shields (that do not extend beyond the front edge of the urinal rim) should be provided with 735mm clearance between them.
- Grab bars to be installed on each side, and in the front, of the urinal.
- The front bar is to provide chest support; the sidebars are for the user to hold on to while standing.

16.8 DRINKING WATER UNITS

- Drinking water fountains or water coolers shall have up front spouts and control .
- Drinking water fountains or water coolers shall be hand-operated or hand and foot-operated.
- Conventional floor mounted water coolers may be convenient to individuals in wheelchairs if a small fountain is mounted on the side of the cooler 800mm above the floor.
- Fully recessed drinking water fountains are not recommended.
- Leg and knee space to be provided with basin to avoid spilling of water . This allows both front and parallel access to taps for persons using mobility aids like wheel chair, crutches etc.

16.9 VISUAL CONTRASTS

- Visual contrasts means adequate contrast created by difference of at least 30 LRV (Light Reflectance Value) of the two surfaces/ objects and it helps everyone especially persons with vision impairments.
- Visual contrast should be provided between:
 - Critical Surfaces (walls, ceiling and floor),
 - Signage and background sign frame/ wall,
 - Step edges and risers/ treads on steps,
 - Handrails and background walls,
 - Doors and surrounding walls,
 - Switches/ sockets and background wall,
 - Toilet fixtures and critical surfaces in toilet.
- Barriers and hazards should be highlighted by incorporating colours and luminance contrast.

16.10 EMERGENCY EGRESS/EVACUATION

- Placement (accessibility) and visibility of such devices is very important. The following is to be considered for the installation of such alarm devices; fire alarm boxes, emergency call buttons and lit panels should be installed between heights of 800mm and 1000mm from the furnished floor surface. These should be adequately contrasted from the background wall and should be labelled with raised letters and should also be in Braille.
-
- A pre-recorded message, alerting an emergency to the control room or reception should be installed in the telephone and this should be accessible by a ‘hotkey’ on the phone keypad. This ‘hotkey’ should be distinct from the rest of the keypad.

16.11 ALERTING SYSTEMS

- In emergency situations, it is critical that people are quickly alerted to the situation at hand, for persons with disability the following needs to be considered.
-
- Consider having audible alarms with ‘voice instructions’ that can help guide them to the nearest emergency exit. As an alternative to the pre-recorded messages, these alarms may be connected to the central control room for on-the-spot broadcasts.
-
- Non-auditory alarms (visual or sensory) to alert persons with hearing impairments should be installed at visible locations in all areas that the passengers may use (including toilet areas, etc).
-

Non-auditory alarms include:

- Flashing beacons
- Vibrating pillows and vibrating beds.
- Pagers or mobile phones that give out a vibrating alarm along with a flashing light (these may be issued to persons with vision or hearing impairments at the time of check-in or boarding the vehicle.)

16.12 WRITTEN EVACUATION PROCEDURE

A written evacuation procedure that details the egress plan for people with disability should be installed behind the entrance door in the accessible rest rooms. The evacuation procedure should be detailed in large print letters that contrast strongly against the background. Where possible, it should also incorporate raised letters and Braille. The evacuation route should be displayed on a high contrast tactile map for benefit of persons with vision impairments.

16.13 EMERGENCY EVACUATION ROUTE

- Designate routes that are at least 1200mm wide, to ensure that a person using a wheelchair and a non disabled person are able to pass each other along the route. The route should be free of any steps or sudden changes in level and should be kept free from obstacles such as furniture, coolers, AC units and flower pots.
- Use Exit signage along the route. Orientation and direction signs should be installed frequently along the evacuation route and these should preferably be internally illuminated. The exit door signage should also be internally illuminated.
- A ‘way guidance lighting system’ consisting of low mounted LED strips to outline the exit route (with frequent illuminated direction indicators along the route) should be installed along the entire length of the evacuation route. Way guidance systems allow persons with vision impairments to walk significantly faster than traditional overhead emergency lighting. Moreover, emergency exit lights in green color and directional signals mounted near the floor have been found to be useful for all people in cases where a lot of smoke is present.

16.14 WAY GUIDANCE SYSTEM

- Luminance on the floor should be 1lux minimum provided on along the centre line of the route and on stairs.
- Install clear illuminated sign above exit and also directional signage along the route.
- The directional exit signs with arrows indicating the way to the escape route should be provided at a height of 500mm from the floor level on the wall and should be internally illuminated by electric light connected to corridor circuits.

16.15 FIRE RESISTANT DOORS

- Fire resistant doors and doors used along the emergency evacuation route are generally heavy and the force required to open these is much higher than 25 Newtons, making it difficult for people with disability to negotiate these doors independently. There are, however, magnetic and other types of door holders available that can be connected to fire alarms so that they will hold the doors open normally but will release the doors when the fire alarm is activated.

16.16 STREET DESIGN

(a) Footpath (Sidewalk)

Footpaths should be regarded as a transportation system which is connected and continuous, just like roadways and railways. They should not be sporadically placed where ever convenient, but instead should be provided consistently between all major attractions, trip generators, and other locations where people walk.

Footpath should:

- Be along the entire length of the road;
- Have height of a standard public step riser i.e. 150 mm maximum;
- Be at least 1800 mm wide;
- Have non-slip surface;
- Have tactile guiding paver for persons with visual impairments;
- Preferably have well defined edges of paths and routes by use of different colours and textures;
- Have no obstacles or projections along the pathway. If this is unavoidable, there should be clear headroom of at least 2200 mm from the floor level;
- The minimum 1.8m (width) x 2.2m (Height) Walking Zone should be clear of all obstructions – both horizontally and vertically.

Footpath should have:

- Have kerb ramps where ever a person is expected to walk into or off the pathway; and
- Have tactile warning paver installed next to all entry and exit points from the footpath.

(b) Kerb Ramp

- Kerb should be dropped, to be flush with walk way, at a gradient no greater than 1:10 on both sides of necessary and convenient crossing points. Width should not be less than 1200mm. If width (X) is less than 1200mm, then slope of the flared side shall not exceed 1:12.
- Floor tactile paving- Guiding & Warning paver shall be provided to guide persons with vision impairment so that a person with vision impairment does not accidentally walk onto the road.
- Finishes shall have non-slip surface with a texture traversable by a wheel chair.

(c) Road Intersections

- Pedestrian crossings should be equipped with traffic control signal.
- Traffic islands to reduce the length of the crossing are recommended for the safety of all road users.
- Warning pavers should be provided to indicate the position of pedestrian crossings for the benefit of people with visual impairments.
- Table tops (raised road level to the sidewalk height) are helpful in reducing the speed of traffic approaching the intersection

(d) Median/Pedestrian Refuge

Raised islands in crossings should:

- Cut through and level with the street; or
- Have kerb ramps on both the sides and have a level area of not less than 1500 mm long in the middle; and
- A coloured tactile marking strip at least 600 mm wide should mark the beginning and end of a median/ pedestrian refuge to guide pedestrian with visual impairments to its location.

16.17 TRAFFIC SIGNALS

- Pedestrian traffic lights should be provided with clearly audible signals for the benefit of pedestrians with visual impairments;
- Acoustic devices should be installed on a pole at the point of origin of crossing and not at the point of destination;
- The installation of two adjacent acoustic devices such as beepers is not recommended in order to avoid disorientation;
- The time interval allowed for crossing should be programmed according to the slowest crossing persons; and
- Acoustical signals encourage safer crossing behaviour among children as well.

16.18 SUBWAY AND FOOT OVER BRIDGE

Subways and foot over bridges should be accessible for people with disabilities. This may be achieved by:

- Provision of signage at strategic location;
- Provision of slope ramps or lifts at both the ends to enable wheelchair accessibility ;
- Ensuring that the walkway is at least 1500 mm wide;
- Provision of tactile guiding and warning paver along the length of the walkway;
- Keeping the walkway; free from any obstructions and projections; and
- Providing for seats for people with ambulatory disabilities at regular intervals along the walkway and at landings.

16.19 ALIGHTING AND BOARDING AREAS

- ▶ All areas and services provided in the Mass Rapid Transit System (Metro/subway), bus terminuses, etc. that are open to the public should be accessible.

16.20 APPROACH

- Passenger walkways, including crossings to the bus stops, taxi stands, terminal / station building, etc. should be accessible to persons with disabilities.

- Uneven surfaces should be repaired and anything that encroaches on corridors or paths of travel should be removed to avoid creating new barriers. Any obstructions or areas requiring maintenance should be white cane detectable².
- Access path from plot entry and surface parking to terminal entrance shall have even surface without any steps.
- Slope, if any, shall not have gradient greater than 5%. The walkway should not have a gradient exceeding 1:20. It also refers to cross slope.
- Texture change in walk ways adjacent to seating by means of tactile warning paver should be provided for persons with vision impairment.
- Avoid gratings in walks.

16.21 CAR PARK

(A) SIGNAGE

- International symbol of accessibility (wheelchair sign) should be displayed at approaches and entrances to car parks to indicate the provision of accessible parking lot for persons with disabilities within the vicinity.
- Directional signs shall be displayed at points where there is a change of direction to direct persons with disabilities to the accessible parking lot.
- Where the location of the accessible parking lot is not obvious or is distant from the approach viewpoints, the directional signs shall be placed along the route leading to the accessible parking lot.
- Accessible parking lot should be identifiable by the International Symbol of Accessibility. The signs should not be obscured by a vehicle parked in the designated lot.
- Vertical signs shall be provided, to make it easily visible, the sign should be at a minimum height of 2100 mm .

(B) SYMBOL

International Symbol of Accessibility should be clearly marked on the accessible parking lot for drivers/riders with disabilities only.

- A square with dimensions of at least 1000 mm but not exceeding 1500 mm in length;
- Be located at the centre of the lot; and
- The colour of the symbol should be white on a blue background.

(C) CAR PARK ENTRANCE

The car park entrance should have a height clearance of at least 2400 mm.

LOCATION

- Accessible parking lots that serve a building should be located nearest to an accessible entrance and / or lift lobby within 30 meters. In case the access is through lift, the parking shall be located within 30 meters.
- The accessible route of 1200 mm width is required for wheelchair users to pass behind vehicle that may be backing out.

(D) ACCESSIBLE CAR PARKING LOT

The accessible car parking lot should:

- Have minimum dimensions 5000 mm × 3600 mm;
- Have a firm, level surface without aeration slabs;
- Wherever possible, be sheltered;
- Where there are two accessible parking bays adjoining each other, then the 1200 mm side transfer bay may be shared by the two parking bays. The transfer zones, both on the side and the rear should have yellow and white cross-hatch road markings;
- Two accessible parking lots shall be provided for every 25 no of car spaces.
-

(E) DROP OFF AND PICK UP AREAS

- Designated drop-off and pick-up spaces, to be clearly marked with international symbol of accessibility.
- Kerbs wherever provided, should have kerb ramps.

Chapter - 17

SECURITY MEASURES FOR A METRO SYSTEM



- 17.0 Introduction
- 17.1 Necessity Of Security
- 17.2 Three Pillars Of Security
- 17.3 Phases Of Security
- 17.4 Responsibilities And Partnerships
- 17.5 Proposed Provisions For Security System



CHAPTER -17

SECURITY MEASURES FOR A METRO SYSTEM

17.0 INTRODUCTION

Metro is emerging as the most favoured mode of urban transportation system. The inherent characteristics of metro system make it an ideal target for terrorists and miscreants. Metro systems are typically open and dynamic systems which carry thousands of commuters. Moreover the high cost of infrastructure, its economic importance, being the life line of city, high news value, fear & panic and human casualties poses greater threat to its security. Security is a relatively new challenge in the context of public transport. It addresses problems caused intentionally. Security differs from safety which addresses problems caused accidentally. Security problems or threats are caused by people whose actions aim to undermine or disturb the public transport system and/or to harm passengers or staff. These threats range from daily operational security problems such as disorder, vandalism and assault to the terrorist threat.

17.1 NECESSITY OF SECURITY

It is well known that public transportation is increasingly important for urban areas to prosper in the face of challenges such as reducing congestion and pollution. Therefore, security plays an important role in helping public transport system to become the mode of choice. Therefore, excellence in security is a prerequisite for Metro system for increasing its market share. Metro railway administration must ensure that security model must keep pace with rapid expansion of the metro and changing security scenario.

17.2 THREE PILLARS OF SECURITY

Security means protection of physical, human and intellectual assets either from criminal interference, destruction by terrorists or criminals or damage/loss incidental to technological failures or natural hazardous events. There are three important pillars of security as mentioned under:

- (i) The human factor;
- (ii) Procedures; and
- (iii) Technology

Engagement of staff with the passengers create a sense of re-assurance which cannot be fully achieved by technology. For human factor to be more effective staff has to be qualified, trained, well equipped and motivated. They should be trained, drilled and tested. The security risk assessment is the first step for understanding the needs and prioritizing resources. The organization of security should be clear and consistent. Security incidents, especially major ones, often happen without warning. Emergency and contingency plans must be developed communicated and drilled in advance.

There are number of technologies which can be used to enhance security e.g. surveillance systems. The objectives of the security systems are multifarious i.e., making planning or execution of an attack too difficult, detect the planned incidence before it occurs, deny access after a plan of attack has been detected and to mitigate i.e. lessen the impact/severity of the attack by appropriate logistic.

17.3 PHASES OF SECURITY

There are three phases of security as under:

Prevention

These are the measures which can prevent a security incidence from taking place. These can be identified by conducting a risk assessment and gathering intelligence. Prevention begins with the daily operational security -problems. Uncared for/ dirty/ damaged property is a breeding ground for more serious crime.

Preparedness

Plans must be prepared to respond to incidents and mitigate the impact. Staff needs to be trained accordingly and exercises carried out. The results of the risk assessment gives a basis for such plans.

Recovery

Transport system need to lay down procedures/instructions for the quick recovery of normal service after an incident. Recovery is important for the financial health of the operation, but it also sends a clear message to public, it reassures passengers and gives them confidence to continue using the system. Communication is key to the quick restoration after such incidents. Restoration should ^also include an evaluation process for the lessons learnt.

17.4 RESPONSIBILITIES AND PARTNERSHIPS

Security is a sovereign function and hence is the responsibility of the state. Security in public requires clear governance. Responsibility should be clearly defined. In the present scenario in Pune and its surroundings, it is the responsibility of the State Government to ensure secured travelling to the public which will include Pune Metro when commissioned.

17.5 PROPOSED PROVISIONS FOR SECURITY SYSTEM:

1. CCTV coverage of all metro stations. With a provision of monitoring in the Station Security Room as well as at a Centralized Security Control Room with video wall, computer with access to internet TV with data connection, printer and telephone connection (Land Line and EPBX) for proper functioning, cluster viewing for stations. Cost of this is included in Telecom estimate.
2. Minimum one Baggage Scanners on all entry points (1 per AFC array). Additional requirement of baggage scanners at heavily crowded stations i.e at interchange may also be required. Cost of one baggage scanner is Rs. 15.0 Lacs approximately, on 2013 prices.
3. Multi-zone Door Frame Metal Detector (DFMD) minimum three per entry (2 per AFC array). The number can increase in view of the footfall at over crowded stations. Cost of one Multi-zone DFMD is Rs 2.15 Lacs approximately.
4. Hand held Metal Detector (HHMD) as per requirement of security agency, minimum two per entry, which varies from station to station with at least 1.5 per DFMD installed at the station. Cost of one HHMD is Rs 6000/- approximately at 2012 prices.
5. Bomb Detection Equipments with modified vehicle as per requirement of security agency. One BDS team per 25 - 30 station will be required at par with present criteria of DMRC. Cost 1.25 crores including vehicle.
6. Bomb Blanket at least one per station and Depots. Cost is Rs. 50,000/- per bomb blanket.
7. Wireless Sets (Static and Hand Held) as per requirement of security agency.
8. Dragon light at least one per station and vital installation.
9. Mobile phones, land lines and EPBX phone connections for senior security officers and control room etc.
10. Dog Squads (Sniffer Dog), at least one dog for 4 metro stations which is at par with current arrangement of Lucknow Metro. Cost of one trained sniffer dog is Rs 1.25 Lacs

approximately. Dog Kennels alongwith provision for dog handlers and MI room will also be provided by metro train depot administration including land at suitable places line wise.

11. Bullet proof Morcha one per security check point (i.e. AFC array) and entry gate of metro train depot administration metro station.
12. Bullet proof jackets and helmets for QRTs and riot control equipments including space at nominated stations. One QRT Team looks after 5-6 metro stations as per present arrangement. One QRT consist of 5 personnel and perform duty in three shifts.
13. Furniture to security agency for each security room, and checking point at every entry point at stations. Scale is one office table with three chairs for security room and office of GO and one steel top table with two chairs for checking point.
14. Ladies frisking booth - 1 per security check point (AFC Arrey)
Wooden Ramp - 1 per DFMD for security check points.
15. Wall mounted/ pedestal fan at security check point, ladies frisking booth and bullet proof morcha, as per requirement.
16. Physical barriers for anti scaling at Ramp area, low height of via duct by providing iron grill of appropriate height & design/concertina wire.
17. Adequate number of ropes. Queue managers, cordoning tapes, dragon search lights for contingency.
18. Iron grill at station entrance staircases, proper segregation of paid and unpaid by providing appropriate design grills etc.
19. Proper design of emergency staircase and Fireman entry to prevent unauthorized entry.

Chapter - 18

MULTI MODAL TRAFFIC INTEGRATION AT METRO STATIONS AND LAND USE



- 18.1 Introduction
- 18.2 Metro Stations And Their Connectivity To City Buses
- 18.3 Access To Metro Stations By Auto Rickshaws
- 18.4 Bicycle Hiring Scheme
- 18.5 Pedestrianization
- 18.6 Land Use In Consonance With Metro Alignment
- 18.7 Ticketing
- 18.8 Conclusion



CHAPTER - 18

MULTI MODAL TRAFFIC INTEGRATION AT METRO STATIONS AND LAND USE

18.1 INTRODUCTION

The proposed Pune Metro Project-Phase I comprises of two corridors viz. Corridor 1- Pimpri-Chinchwad Municipal Corporation (PCMC) to Swargate and Corridor 2 – Vanaz to Ramwadi. Corridor 1 is generally oriented along North-South and Corridor 2 along West – East. The two corridors have an interchange point. The length of Corridor 1 is 16.589 km and that of Corridor 2 is 14.665 km, thus totaling to a length of 31.254 km. Metro System does not end at the entry or exit doors of the stations but rather encompasses the entire commuter capture area. While the Metro will go to provide a high capacity corridor to carry the passengers, its integration with other transport modes as well as its accessibility to pedestrians is essential to facilitate seamless transfer of commuters which will in turn lead to enhanced ridership on the Metro System. The concept is to provide at last last mile or half mile connectivity to the commuters residing/working in the Metro Influence Zone. MoUD laid down policy guidelines to include this important aspect of last mile connectivity in the DPRs for the Metro Systems vide their letter no. MoUD (Urban Transport Wing) Advisory Circular no. K-14011/1/2007-UT-IV dated 30.08.2013. This connectivity is expected to be achieved through proper access to the Metro Stations by City Buses, Shuttle services, Intermediate Public Transport (Auto Rickshaws), bicycles and pedestrianization.

Pune Metro-Phase I alignments generally traverse areas of city which are already well developed. Public Transport in Pune city is presently served by a network of bus routes operated by PMPML (Pune Mahanagar Parivahan Mahamandal Ltd.), which is a company owned by Govt. of Maharashtra, Pune Municipal Corporation and Pimpri-Chinchwad Municipal Corporation. PMPML operates a fleet of over 1000 buses along more than 350 Bus Routes. Addition of 500 more buses is under process under JNNURM. Out of the 350 routes approximately 85 routes provide connectivity to Metro Stations at one or more points. Two wheelers account for more than 35% of the modal share and it is a challenge for the Metro to attract two wheeler riders to the Metro. Auto Rickshaw is a principal mode of IPT and approximately 8 % trips are accounted for by this mode. Thus facilities for boarding and alighting from Autos at the Metro Stations will need special attention while conceptualizing the station layouts. Pedestrian access to various locations has largely improved through improved footpath widths and their surfaces as a sequel to implementation of various projects such as JNNURM. In Pune and surrounding areas suburban trains are very few in number and their share is hardly 1%. However seamless

integration of Metro wherever it touches the main line railway system does need appropriate attention.

However, any such changes to facilitate access of various modes to the Metro stations needs to be viewed carefully, keeping in view various constraints in the already developed city areas such as available road width, availability of parking and lay out and availability of circulating areas at the Metro Stations, Business centre or markets & existing traffic densities.

18.2 METRO STATIONS AND THEIR CONNECTIVITY TO CITY BUSES

18.2.1 General

Pune City and its surrounding areas has a dense network of city buses which connect a number of proposed Metro Stations to the major residential and commercial areas. In order to appreciate the available bus connectivity to Metro Stations from surrounding areas, an exercise has been carried out to chart the bus routes leading to some of the important interchange points with Metro. This data has been processed and presented in the form of Radial Charts which are presented at Fig. 18.3 to Fig. 18.19. This has produced valuable information which leads to defining any need for augmentation of bus services at certain Metro Stations to ensure better connectivity to surrounding areas. It also provides a handle to plan site specific facilities at each Metro Station. The details are enumerated in following paragraphs.

18.2.2 Corridor 1 Metro Station connectivity to Buses

Sr. No.	Metro Station	Connectivities of important stations with City Bus System and other features
1	Swargate	<p>Swargate is a terminal point of Corridor 1 (PCMC-Swargate). Swargate Metro will feature a passenger boarding of 17358 in 2018, which is the highest amongst all the stations.</p> <p>A number of City Bus Routes pass through Swargate. In addition Swargate has a major State Transport Bus Terminus. The underground Metro Station is proposed to be located below the Satara Road in between the State Transport Bus Terminus and Bus Stop area of city buses. It is proposed to plan the Metro station in such a way that a seamless integration with both these bus services is accomplished with pedestrian underpasses connecting the three facilities.</p> <p>The planning of Swargate Inter Modal Transit Centre (IMTC) is also currently underway which envisages provision of a state of the art bus stand cum commercial complex in two wings (on two sides of Satara Road) one at the State Transport Bus Stand location and the second at the City Bus Stand location, which are planned to be</p>

		<p>interconnected by a sky walks apart from pedestrian underpasses. This complex is being conceptualized keeping in view the requirement of seamlessly integrating the Metro System with the two bus complexes. A parking lot to accommodate approximately 8000 two wheelers and 2500 cars is also conceived. Fig. 18.1 and Fig. 18.2 brings out the artist's view of the proposed complex. This project is under initial conceptual stage.</p> <p>Fig.18.3 brings out the radial chart of City Bus Connectivity at Swargate. From the chart it could be noticed that Swargate is well connected with surrounding residential/ commercial areas with large number of Bus Routes (N) with a very low effective Frequency (F in minutes). The access to Autos and pedestrians is also planned to be further enhanced through underpasses and development of IMTC.</p>
2	Mandai	<p>Mandai is the main Market Center along Corridor 1. The bus connectivity from the north between Shaniwar Wada and Mandai (along Shivaji Rd) is very high with effective frequency of 1.1 Min (Fig 18.4). From the city area along the West due to introduction of One Way Road working (on Bajirao Rd) the station falls at about 500 m away from the bus corridor along which the effective frequency of buses is 1.1 Min. Mandai and its surroundings are predominantly Pedestrian dominated areas and the last ½ mile connectivity will be essentially by walking. While detailing this station this aspect will be kept in view. Presently two large parking complexes (Aryan & Minerva) are in place at Mandai and further reservations for Parking have been demarcated in the new Development Plan of the city.</p>
3	PMC	<p>PMC is located at the end of Shivaji Bridge along Corridor 1. Most of the buses coming from the city going towards Shivajinagar pass through this route. From the city area (Bajirao Rd) the effective frequency is 1 Min. From Rasta Peth/Phadke Haud the effective frequency is 5 Min. (Fig. 18.5)</p>
4	Shivajinagar	<p>Shivajinagar Metro along Corridor 1 is proposed to be located below the existing State Transport Terminus adjacent to Shivajinagar Rly Station. It features interchange with City Buses (which ply in large nos through ShivajinagarStn), State Transport Buses and Central Railway. Central Railway is currently planning a Model Station Complex at Shivajinagar Station and it is proposed to dovetail the access to the underground Metro Station into to this railway complex as well as to the State Transport Bus Terminus and Bus Stands leading to their seamless integration. The major residential and commercial areas which will need connectivity to this station are along University Road upto Pune University and Yashada. The</p>

		effective bus frequency along this route is 1.8 Min (Fig.18.6). Shivajinagar Metro is well accessed by Footpaths along the various roads which lead to this location.
5	Khadki	Khadki Metro on Corridor 1 is along Mumbai Pune Road adjoining Khadkai Railway Station. Seamless integration with Pune-Lonavla suburban railway system is accomplished at Khadki. Mumbai-Pune Road between Shivajinagar and Khadki has a number of bus routes with effective frequency of 3.5 Min which will go to provide adequate connectivity to residential/commercial areas along this stretch. Bus connectivity with effective frequency of 5 Min is available from BEG and Deccan College area across the Mula River towards southeast (Fig.18.7). To the West of KhadkiStn is a defence area which is sparsely populated.
6	Dapodi	Dapodi Metro along Corridor 1 is along Mumbai-Pune Road. To the East of this station is sparsely populated CME campus and defence area. Residential/commercial area along small strip of land between the Mumbai-Pune Road and Railway tracks gets access to Dapodi Metro by walk. The residential area towards west across the railway tracks have a bus connectivity with effective frequency of 4.3 Min. (Fig. 18.8)
7	Bhosari/ Nashik Phata	Bhosari Metro is located along Mumbai Pune Road adjoining Kasarwadi Railway Stn. Seamless integration with Pune-Lonavla suburban railway system is accomplished at Bhosri. Bus connectivity is available from BhosriGaon, MIDC etc. towards northest at an effective frequency of 7.4 Min. (Fig. 18.9). Residential/commercial area along small strip of land between the Mumbai-Pune Road and Railway tracks gets access to Bhosari Metro by walk.
8	PCMC	PCMC Metro is the north end terminal of Corridor 1. The residential/commercial area to the north of this stn. Upto Nigdi along Mumbai-Pune Road is connected by Buses at an effective frequency of 2.1 Min. ChinchwadGaon and surrounding residential/ commercial areas get connected by buses at effective frequency of 4.3 Min. (Fig. 18.10).



Fig. 18.1: Swargate IMTC Plan



Fig. 18.2: Swargate IMTC Perspective

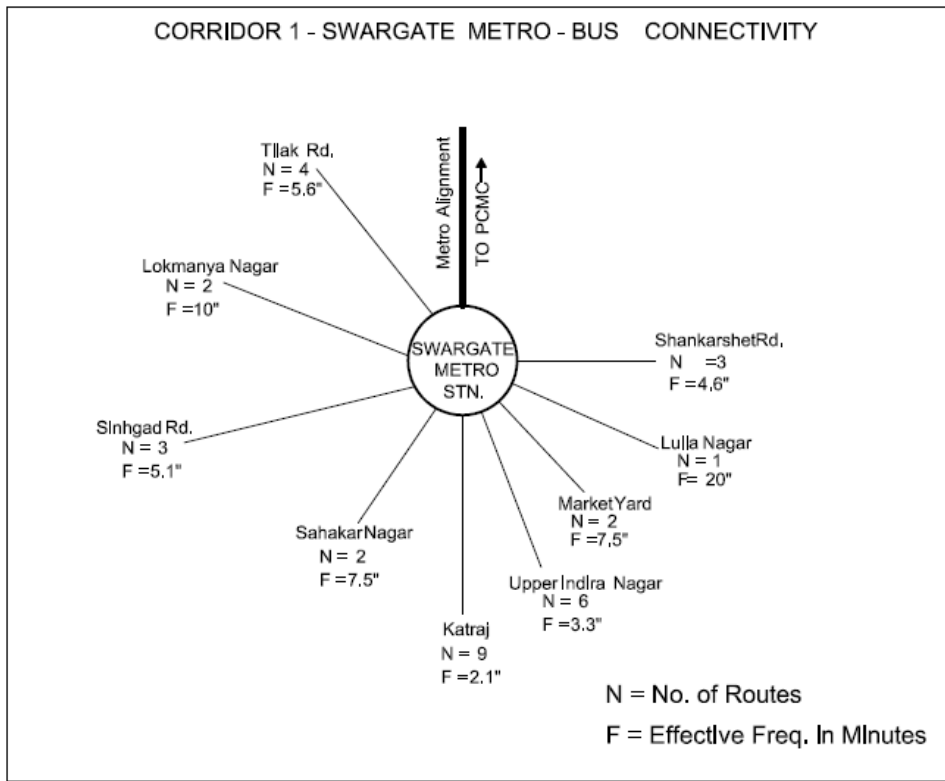


Fig. 18.3: Swargate Bus Connectivity

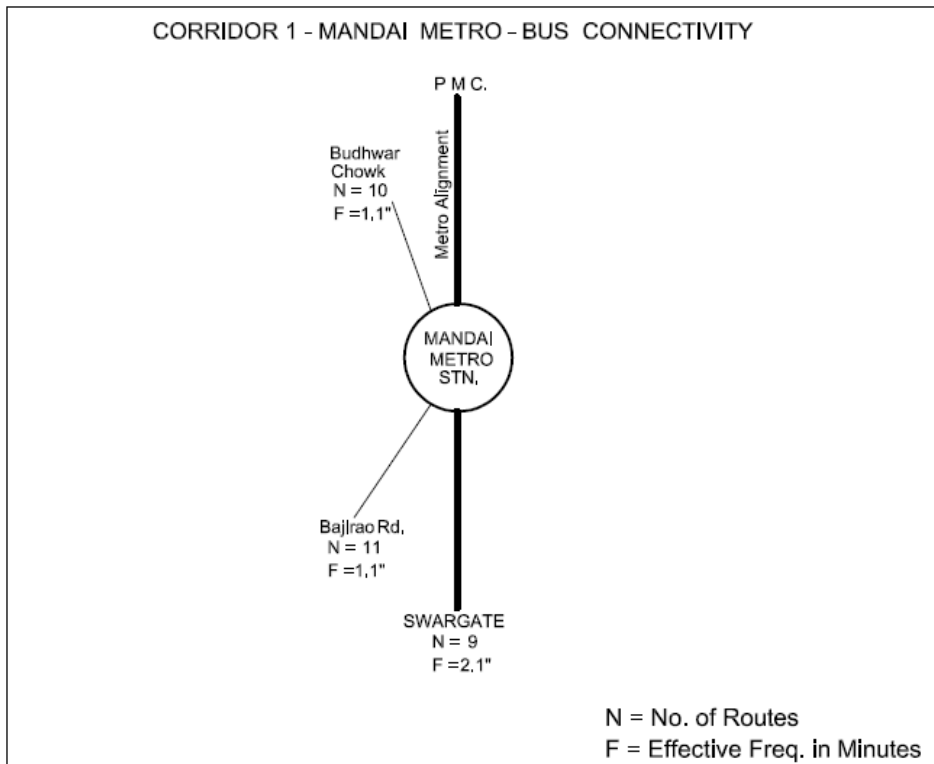


Fig. 18.4: Mandai Bus Connectivity

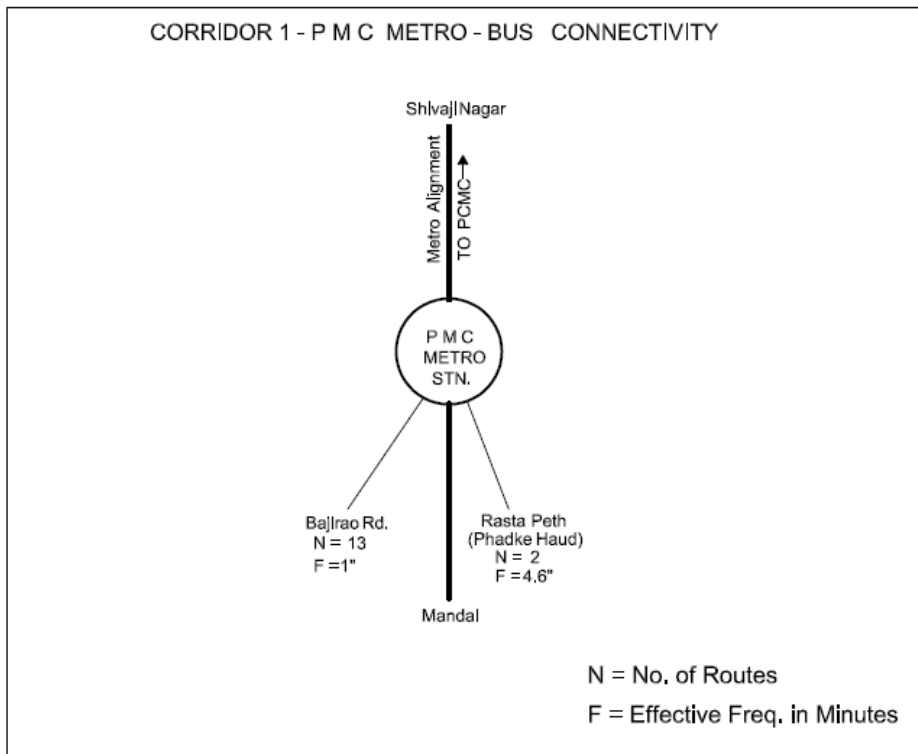


Fig.18.5: PMC Mandai Bus Connectivity

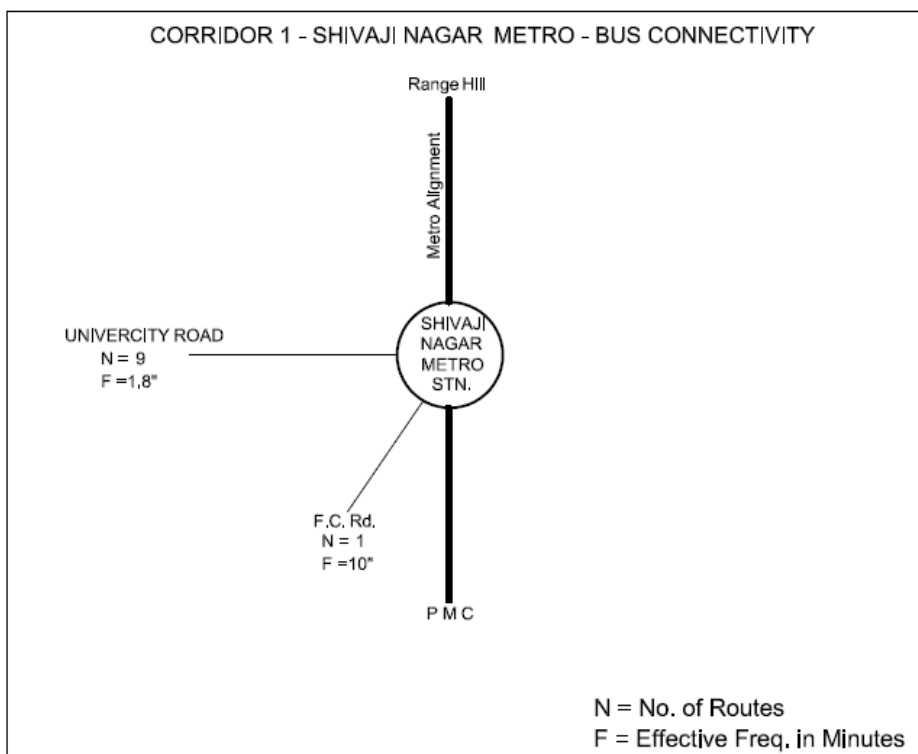


Fig. 18.6: Shivajinagar Bus Connectivity

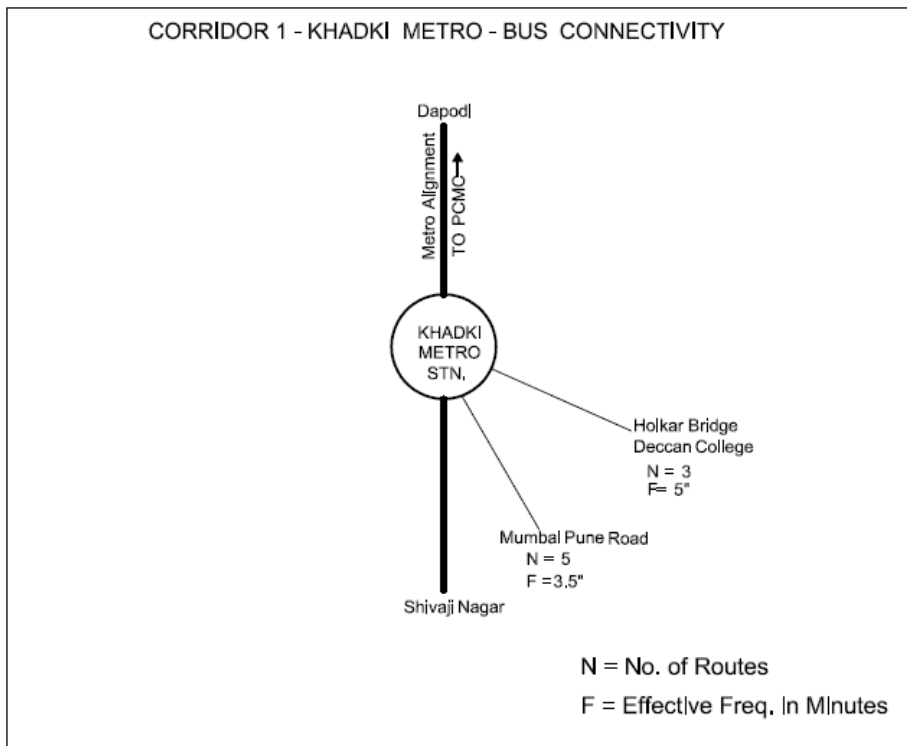


Fig.18.7: Khadki Bus Connectivity

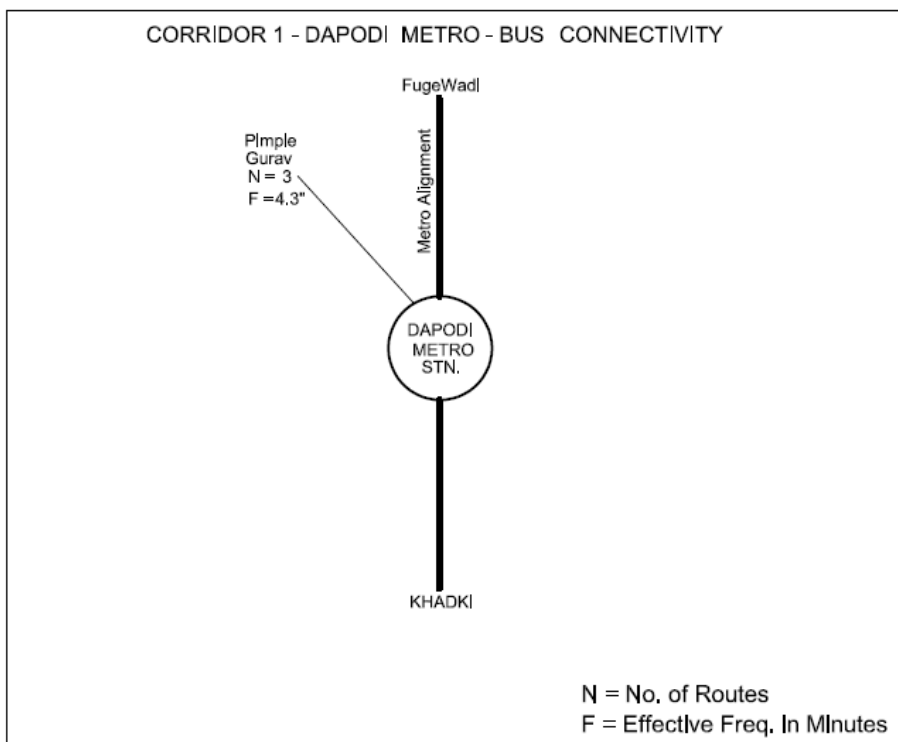


Fig.18.8: Dapodi Bus Connectivity

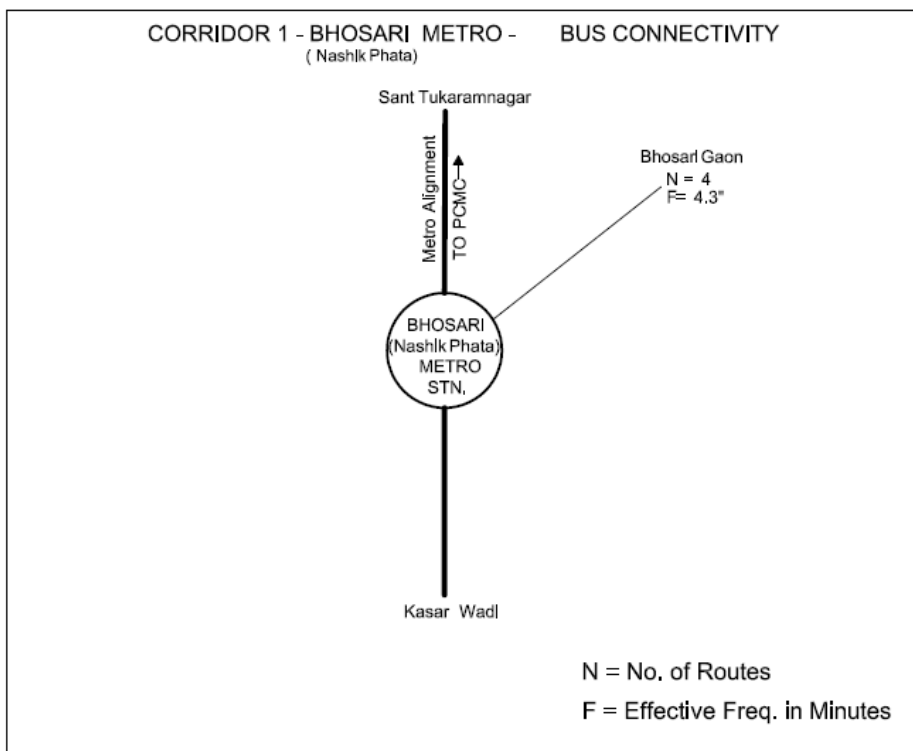


Fig.18.9: Bhosari (Nashik Phata) Bus Connectivity

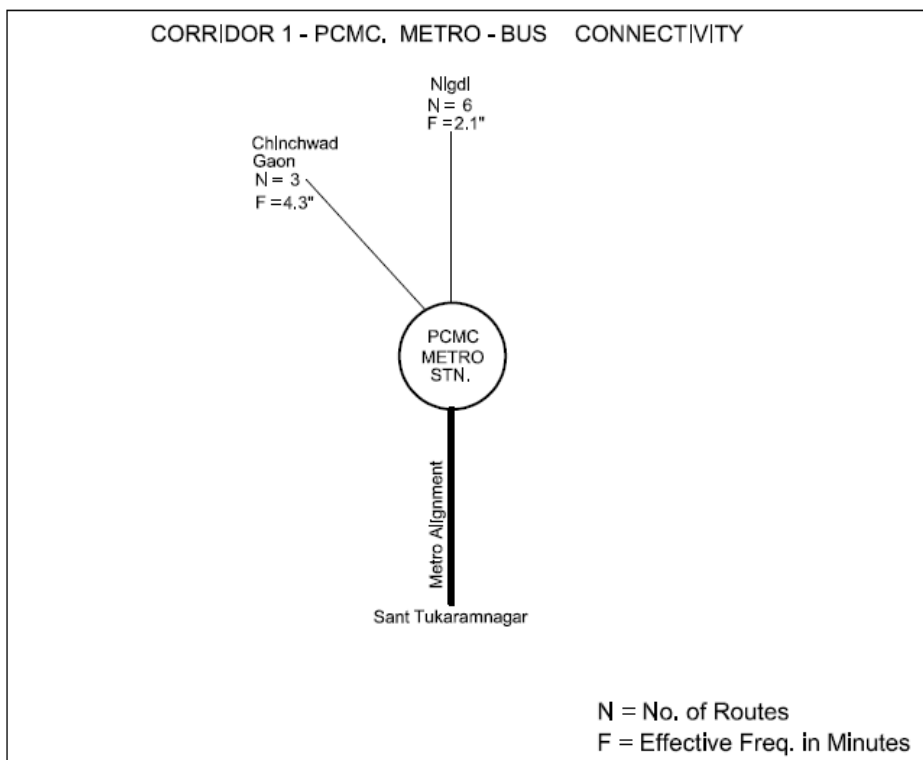


Fig. 18.10: PCMC Bus Connectivity

Important interchange Metro Stations along Corridor 1 are thus seen to be well connected by PMPML Bus services running at comfortable frequencies. Along Mumbai-Pune Road the effective frequency of Buses is around 2 Min. Thus on the portion of this corridor between PCMC and Khadki (covering stations at Sant Tukaram Nagar, Bhosri, Kasarwadi, Dapodi, Bopodi) residential/commercial areas falling in the Metro Influence Zone will get connection to the nearest Metro station with these bus services.

New upcoming residential areas along Moshi- Pimpri Corridor towards the East of Mumbai Pune Road will need certain augmentation in terms of new bus services. PMPML being a part of PMC & PCMC this issue could be coordinated and new bus services introduced to satisfy the needs of Metro Connectivity of these newly developing areas on commissioning of Metro Corridor 1. This issue is best left to be addressed at that time as many of these areas are still in a nascent stage of development.

18.2.3 Corridor 2 Metro Station connectivity to Buses

Sr. No.	Metro Station	Connectivities of important stations with City Bus System and other features
1	Vanaz	Vanaz is a terminal point of Corridor 2 (Vanaz-Ramwadi). To the north of Vanaz is a hilly area with a small strip of residential area along the Paud Rd. The major residential area is towards south (Kothrud). Kothrud is generally connected by city buses running towards east through the township to Nal Stop and not Vanaz. Presently there is only one service at a frequency of 20 Min which connects Kothrud township to Vanaz Metro. Towards east of Vanaz is township of Bavdhan beyond a hillock. This is connected by one bus service at a frequency of 20 Min. (Fig. 18.11)
2	Nal Stop	Nal Stop Metro will be a major interchange point between buses and Metro along Corridor 1. Area towards west of Nal Stop along Karve Road is a major residential area. The effective frequency of buses leading to Nal Stop from this area comprising Warje and Kothrud township is 1.6 Min. (Fig. 18.12) Autos is another mode by which commuters will access this station. These aspects shall be kept in view while conceptualizing Nal Stop Metro Station. For two wheelers emanating from this area a reservation has already been made for Parking Lot at Ideal Colony Metro along this alignment.
3	Garware College	Garware College Metro along Corridor 2 is well connected by buses form city area along Tilak Road. The effective frequency of buses from Tilak Road is 6.6 Min. (Fig. 18.13) The city area comprising Tilak Road & Laxmi Road is also well connected to Deccan Gymkhana Metro on Corridor 2.

4	Deccan Gymkhana	Deccan Gymkhana Metro along Corridor 2 is well connected by buses to the City (Tilak Road, Shastri Road) and to Fergusson College Road. The effective frequency of buses from Tilak Rd, Shastri Rd and Fergusson Rd are 5.7, 4 and 4.8 Minutes respectively (Fig. 18.14).
5	ASI	ASI Metro is well connected by buses to the city area (Bajirao Rd, Shivaji Rd). The effective frequency of buses leading to & from these roads is 1 Min (Fig. 18.15).
6	Pune RS	Pune Metro is located adjacent to Pune Railway Station and main State Transport Bus Terminus and PMPML bus stands. A seamless integration of all these modes is proposed to be ensured while evolving detailed conceptual plan of this important Metro Interchange Station. The effective frequency of buses from City area (Rasta Peth, JN Rd) is 1.7 Min and from West End/East Street is 2.1”(Fig. 18.16).
7	Bund Garden	Bund Garden Metro along Corridor 2 gets connectivity by buses from Deccan College area by buses running at effective frequency of 4.3 Min (Fig.18.17). However, it has practically NIL connectivity by buses with North Main Rd, Koregaon Park. PMPML will be required to introduce a new bus route from Bund Garden Metro to Kalyani Nagar Metro via North Main Rd- Koregaon Park. This will facilitate connectivity of Kalyani Nagar a major residential and commercial area to Kalyani Nagar Metro along Corridor 2 and connectivity of Koregaon park to Bund Garden Metro along Corridor 2.
7	Yerwada	Yerwada Metro along Corridor 2 is well connected by buses to & from Jail Road which has a number of residential and commercial complexes. The effective frequency along this bus route is 2.5 Min. Connectivity by buses is also available to Deccan College area with effective bus frequency of 6 Min (Fig. 18.18). However Deccan College area also gets connectivity by other set of buses to Corridor 2 at Bund Garden.
8	Ramwadi	Ramwadi is a terminal station along Corridor 2. The area beyond Ramwadi along Nagar Road such as Vadgaon Sheri, Kharadi etc. are well connected to Ramwadi by buses with effective frequency of 2.6 Min (Fig. 18.19). However, the Commercial/Residential complexes in VimanNagra lack adequate bus connectivity to Ramwadi Metro and will need augmentation.

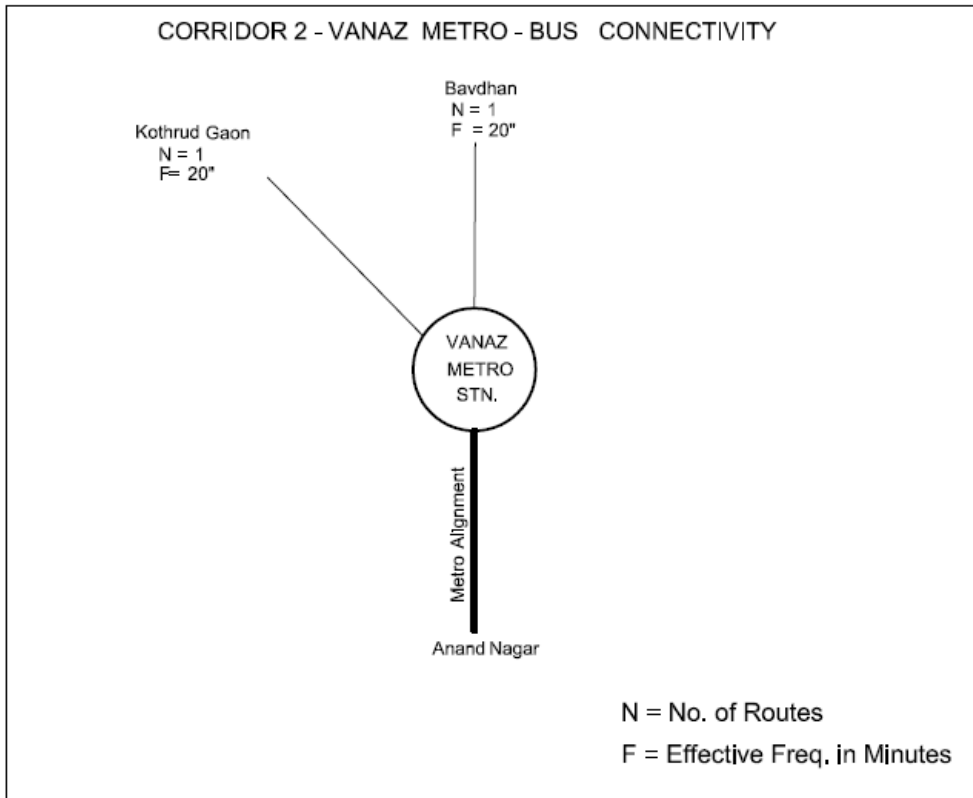


Fig. 18.11: Vanazi Bus Connectivity

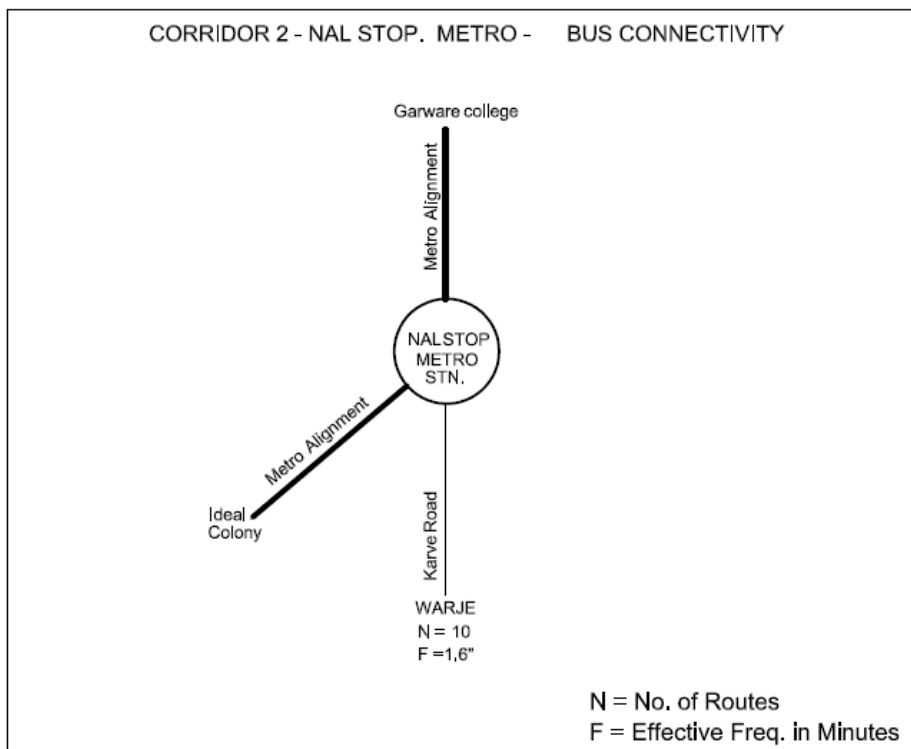


Fig.18.12: Nal Stop Bus Connectivity

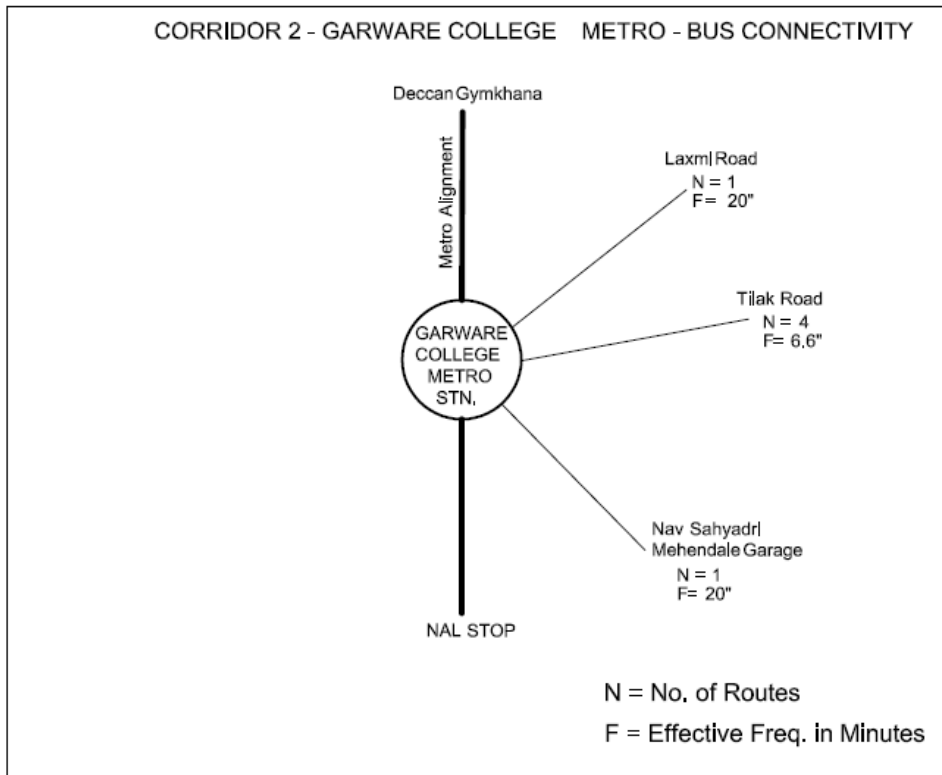


Fig.18.13: GarwareCollege Bus Connectivity

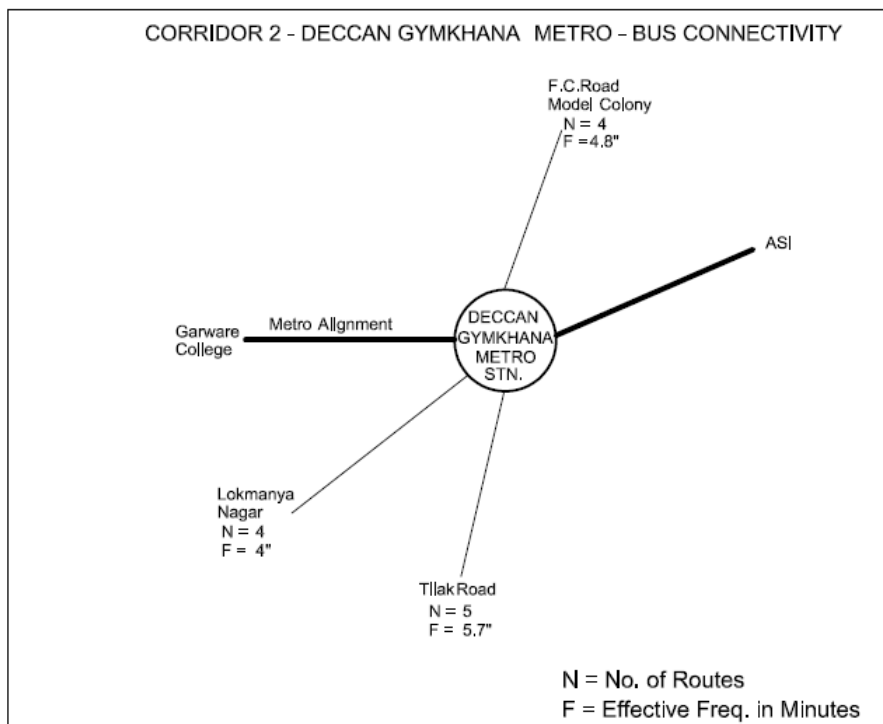


Fig. 18.14: Deccan Gymkhana Bus Connectivity

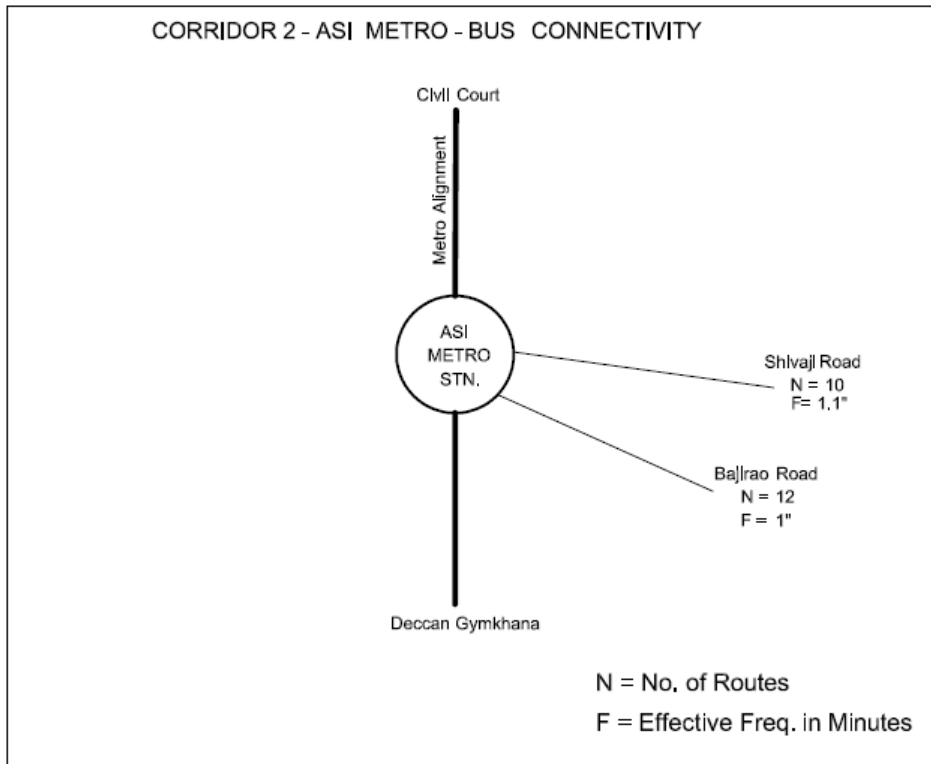


Fig.18.15: ASI Bus Connectivity

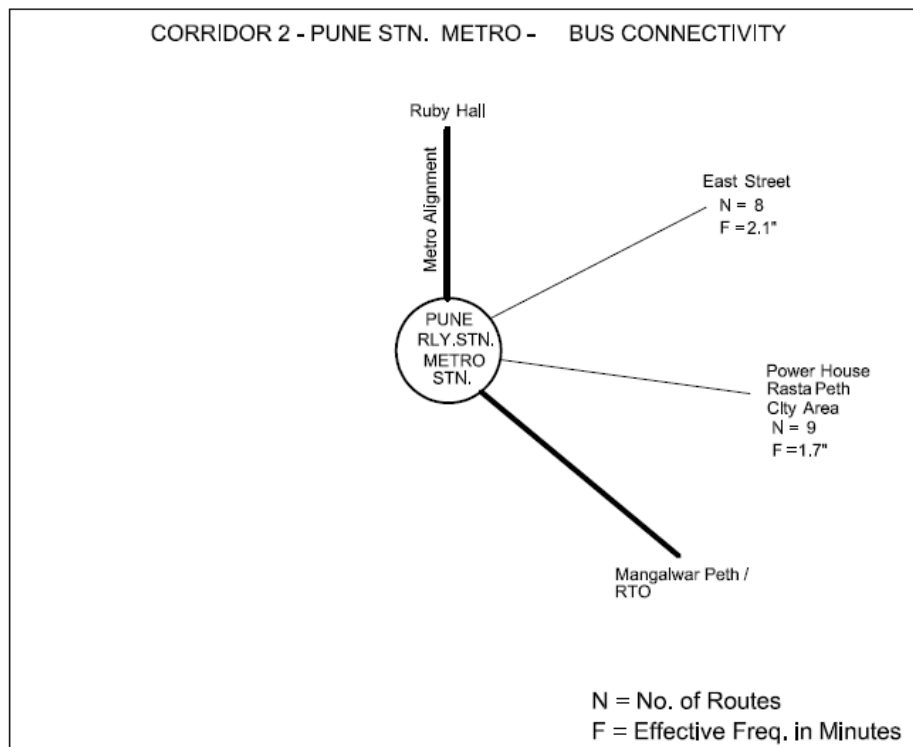


Fig. 18.16: Pune Stn Bus Connectivity

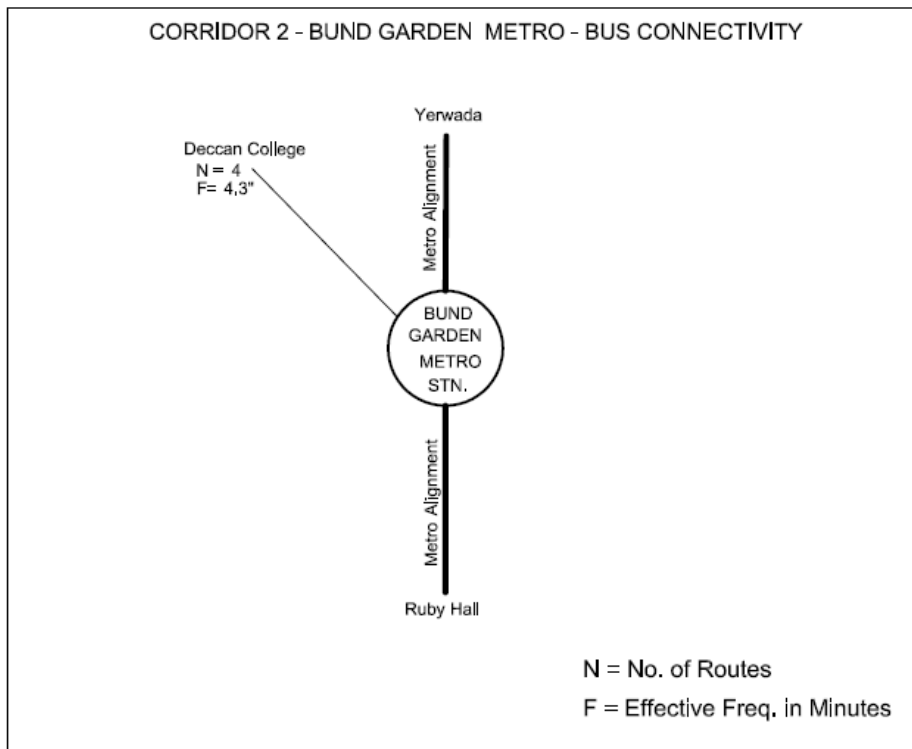


Fig. 18.17: Bund Garden Bus Connectivity

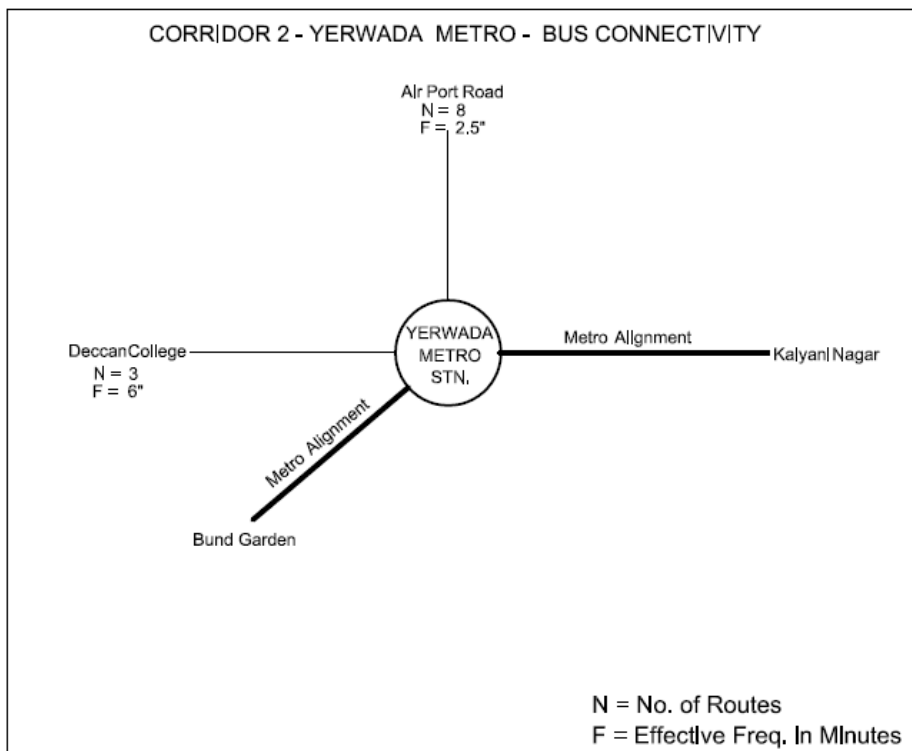


Fig.18.18: Yerwada Bus Connectivity

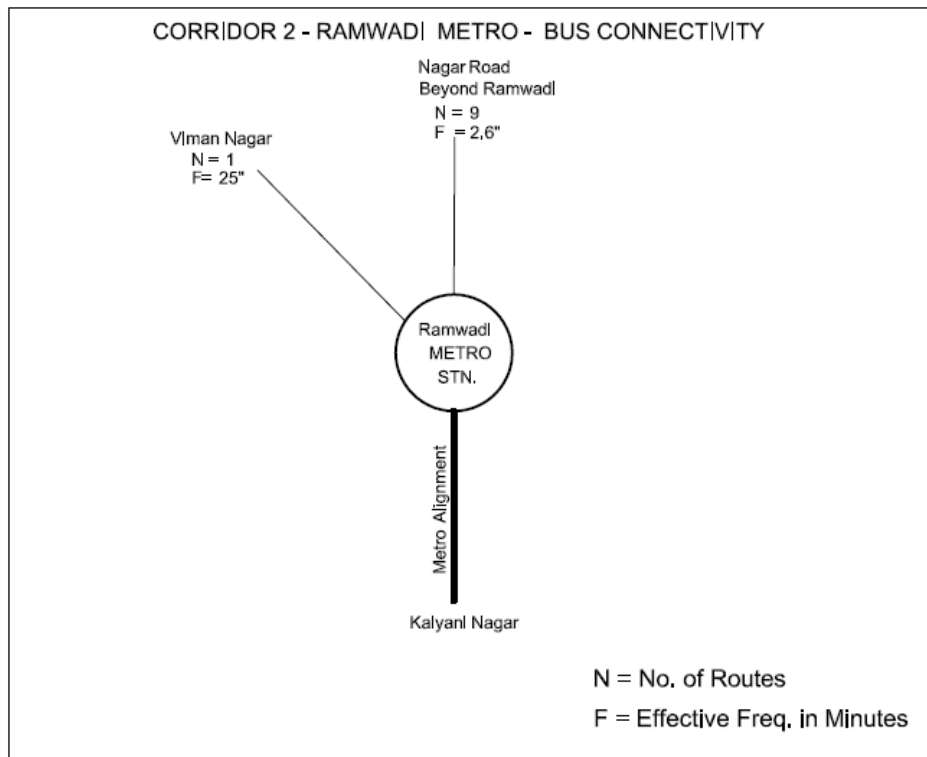


Fig.18.19: Ramwadi Bus Connectivity

Important interchange Metro Stations along Corridor 1 viz. Deccan Gymkhana, ASI, Pune Railway Stn are thus seen to be well connected by PMPML Bus services running at comfortable frequencies.

PMPML bus services will need to be reorganized in the vicinity of Vanaz, Bund Garden, Kalyani Nagar and Ramwadi along this Metro Corridor and following will need implementation by PMPML

- (i) New services from Vanaz to Bavdhan/ Bhugaon affording connectivity to residential/commercial areas.
- (ii) New services from Bund Garden to Kalyani Nagar via Koregaon park affording connectivity to Kalyani Nagar and Koregaon Park.
- (iii) New services from Ramwadi to Viman Nagar affording connectivity to the residential/commercial complexes in that area.

It will be possible to reorganize the bus services after commissioning of Metro and deploy buses along the above bus routes within the resources of PMPML.

18.3 ACCESS TO METRO STATIONS BY AUTO RICKSHAWS

In the IPT category Autos are one of the main modes of commuter transport over short and medium distances in Pune (modal share of about 8 %). It is therefore imperative to provide suitable auto bays for boarding and alighting of commuters at the Metro Stations. While detailing the Metro Stations, site specific designs are proposed to be evolved to address this important requirement in the city of Pune. Due to the Metro traversing already developed city areas there are likely to be certain constraints in fully accomplishing this goal, however, the endeavour will be to provide such facilities at as many Metro Stations as possible.

18.4 BICYCLE HIRING SCHEME

A proposal for bicycle hiring scheme is already under active consideration of Pune Municipal Corporation. 40 hubs for delivery and receipt of hired bicycles are envisaged under this scheme. Out of these 17 hubs are within 500 m to 3 km of Metro Stations. While implementing the Metro Project and detailing the stations some of the stations need to be identified as Hubs for bicycle hiring scheme. This will enhance the efficacy of this scheme and Pune being known as a bicycle city about three decades back will certainly return back to become one in the present days of spiraling fuel prices.

18.5 PEDESTRIANIZATION

If it is not convenient or easy to walk to the station, then the commuters will be discouraged from using the Metro. High quality pedestrian access can be accomplished through design factors such as directness and connectivity, ease of movement, safety and security. A large number of works have been carried out to upgrade the footpaths along many of the roads in Pune under JNNURM. As a result of this the city presents desired widths and surface finish of footpaths along its main roads. In the vicinity of majority of Metro stations the footpaths stand upgraded. If the vendor menace on these upgraded footpaths is eliminated then the desired accessibility of pedestrians to Metro Stations could be accomplished. New pedestrian subways which are being provided adjacent to Metro stations (e.g. Swargate) are already being conceptualized keeping in view the access to Metro commuters. Mapping the quality of pedestrian facilities around the stations is a basic first step to identify barriers and difficulties likely to be faced by commuters. While planning the Metro Stations footpath accesses are proposed to be reviewed with reference to the above important criteria. Based on this study requisite inputs are proposed to be made if the situation demands any improvement.

18.6 LAND USE IN CONSONANCE WITH METRO ALIGNMENT

Phase I of Pune Metro which is a subject matter of this DPR traverses already developed city area and therefore there is limited scope for any radical changes to the current land use. One of the major policy intervention in this regard is to increase the FAR to 4 within the Metro Influence Zone comprising a strip of 500 m width on either side of the Metro alignment. While according approval to Pune Metro Project- Phase I, Government of Maharashtra has already resolved to increase FAR along the Metro Influence Zone to 4 (from the present 1). This will provide an impetus to the renewal of old and dilapidated city areas and bring about desired densification along the Metro Corridors.

Pune is also in the process of finalizing a new Development Plan. While evolving this plan in the already built city areas certain reservations have been made for Parking Plazas adjacent to the Metro Stations, which will lead to a positive effect on ridership of the Metro. It will play a significant role, particularly in attracting Two Wheeler users to the Metro.

It is the Phase II of the Pune Metro which will seek to connect farther areas which are still to be developed. Thus once the Phase II Metro alignments get decided in future it will be necessary to realign the Land Use plans in the influence areas of these Metro alignments.

18.7 TICKETING

With the rapid advancement in technology and communication revolution Pune Metro will be looking at integrating the ticketing between Metro and City Bus System. A common plastic card to facilitate use in both the modes of transport and also for parking at Metro Parking Lots shall be considered in order to bring about efficiencies and saving in commuter time. For the credit and debit purpose the transactions could be connected through common secured gateways.

18.8 CONCLUSION

One of the major objectives of the Metro is to wean away commuters from using personalized modes of travel within the city. Primary reason for using personal vehicle (for buying vehicle) is to save travel time during journey. In order to attract users of personalized travel (particularly two wheelers) a seamless integration of various modes of public transport and IPT is necessary. While planning high ticket projects such as a Metro System this issue gains much more importance.

As can be noted from above most of the important Metro Stations of Pune Metro Phase-I are well connected with various adjacent localities by City Bus Service. Once the Metro gets commissioned the City Bus service could be rationalized. With this it should be possible to

manage the areas which suffer from lack of connectivity by redeployment of buses from the existing fleet. Thus no extra cost is envisaged in the DPR estimates.

The Bus Operator PMPML being partly owned by Pune Municipal Corporation and Pimpri-Chinchwad Municipal corporation and the proposed Pune Mahanagar Metro Rail Corporation Ltd, which will also be partly owned by these two organizations, Pune Metro will be in a advantageous position to accomplish the goal of seamless integration (including ticketing) amongst these important modes of Public Transport. The ownership pattern of Pune Metro will also benefit in a better say in implementing Land Use policies in consonance with the Metro alignments.

While working out detailed plans and specifications all the above aspects shall be kept in view in order to accomplish the set goals.

Chapter - 19

Conclusion & Recommendations





CHAPTER - 19

CONCLUSIONS AND RECOMMENDATIONS

- 19.1** Pune has witnessed enormous industrial growth during the last 10 years. Rapid urbanization in the recent past has put the city's travel infrastructure to stress. With a large number of units have come up both in small scale as well as in heavy & medium scale industry, etc., traffic in the city is expected to shoot up. Being thickly populated area, Pune's traffic needs cannot be met by only road-based system.

The existing urban transport system of Pune City which is road-based has already come under stress leading to longer travel time, increased air pollution and rise in number of road accidents. With projected increase in the population of the city strengthening and augmenting of transport infrastructure has assumed urgency. For this purpose provision of rail-based Metro system in the city has been considered.

Studies have brought out that a Medium Capacity Metro with carrying capacity of about 25,000 phpdT will be adequate to meet not only the traffic needs for the present but for the future 30 to 40 years also. A medium capacity Metro System consisting of two Corridors namely (i) PCMC – Swargate Corridor (16.59 km) and Vanaz - Ramvadi Corridor (14.67km) at an estimated completion cost of **Rs. 10700.00** crores (Central taxes & duties) to be made operational has accordingly been recommended

- 19.2** A detailed Environmental Impact Assessment Study has been carried out for the project. As a part of this Study, comprehensive environmental baseline data was collected, and both positive and negative impacts of the project were assessed in detail. The project has many positive environmental impacts like reduction in traffic congestion, saving in travel time, reduction in air and noise pollution, lesser fuel consumption, lesser road accidents etc, with a few negative impacts (especially during implementation phase of the project) for which Environmental Management Plan has been suggested.
- 19.3** Issues pertaining to (i) Disaster Management, (ii) Security and (iii) Disabled Friendly Features have been discussed and measures to be implemented clearly brought out in this Project Report. Measures to be taken for accomplishing Multi Modal Traffic Integration have been addressed in details. Measures contemplated for directing the Land Use in tune with the proposed Metro alignments have also been spelt out in this Report.
- 19.4** After examining the various options for execution of Pune Metro Project, it has been recommended that the project should be got executed through a SPV on DMRC funding pattern

- 19.5** The fare structure has been estimated based on Delhi Metro fares decided by the fare fixation committee in 2009 duly escalating the same for year 2020. Subsequently, for the purpose of assessing returns from the project, the fares have been revised every second year with an escalation of 12% every two years.
- 19.6** As in the case of Delhi Metro, the State Government should exempt/reimburse the Maharashtra Value Added Tax (VAT) to Pune Metro. It should also exempt the following: -
- Tax on electricity required for operation and maintenance of the metro system.
 - Municipal Taxes.
- 19.7** As per the present policy 50% of the Central Taxes will be paid by GOI as subordinate Debt and balance 50% will be paid by the concerned State Government. Pune State Government may pursue the Central government to extend the same benefit to Pune Metro.
- 19.8** While the Financial Internal Rate of Return (FIRR) for the project has been assessed as **6.87%** without additional development charges and surcharge on stamp duty & registration fees and **13.60%** with additional development charges and surcharge on stamp duty & registration fees and the Economic Internal Rate of Return (EIRR) works out to **16.32%**.

without additional development charges and surcharge on stamp duty & registration fees)

- 19.9** To avoid delays in processing the clearance for the Project, It is suggested that immediately on receipt of the DPR, the State Government should approve it 'in principle' and forward the DPR to the Secretary, Ministry of Urban Development, Government of India, advising the GOI of the State Government's intention to take up the Project on DMRC pattern requesting for the latter's "in principle" clearance to go ahead with the Project.
- 19.10** An SPV should be set up for Pune Metro and registered under the Companies Act, 1956. This SPV should be a PSU of the State Government and may be named as 'Pune Mahanagar Metro Rail Corporation Ltd.' (PMMRC).
- 19.11** Since sanction of Pune Metro may take some time, It is recommended that the State Government should urgently post an Officer on Special Duty (OSD) with adequate powers to process and pursue sanction for this project and to initiate preliminary steps required for its implementation.
- 19.12** Meanwhile the State Government should freeze all future developments along the proposed route of Pune Metro to avoid infructuous expenditure.
- 19.13** Since the SPV to be set up to get the project implemented and initially the SPV may lack in expertise, it will be necessary to engage Interim Consultants for the first one year who will do this job on behalf of the SPV in preparation of land plans, transferring the alignment from

drawing to the ground, fixing the contracts for some of the selected elevated packages and depots. Interim consultant will also help in finalization of General Consultants.

- 19.14** To keep a check on the work of General Consultants and to ensure that the Metro is being constructed to meet the appropriate specifications and safety standards, the SPV may perhaps need to engage the services of Prime Consultants who will keep over-all watch over the execution of the project.

PREFACE

Delhi Metro Rail Corporation prepared the Detailed Project Report for Pune - Pune Chinchwad area and submitted to Pune Municipal Corporation in July, 2009. Subsequently, this DPR was updated to the price level of January, 2013 and last updated in August, 2014. Both these updations had only revision of the cost and re-working of the Financial Internal Rate of Return (FIRR).

Decision on the implementation of the Pune Metro could not be taken for the various reasons. Hon'ble Chief Minister of Maharashtra himself took the initiative and constituted a committee to iron out the differences in the proposals made by various Groups. However, final meeting was taken by the Hon'ble Central Minister of RTH&S on 09.09.2015, wherein it was decided that the Pune Metro should be implemented with the minor changes in the alignment of Corridor-II (Vanaz – Ramavadi corridor near Jangli Maharaj Road). It was decided that the alignment should avoid Jangli Maharaj Road and run along the left bank of Mutha River. Accordingly, DMRC has revised the alignment of Corridor-2 and prepared this Report with updation of price level to November, 2015 and assessment of financial viability for the entire project to be commissioned in 2021.